

Arrangement 9 - 9CB centrifugal fan

Arrangement 9: Models PB - PBS - SPB - LM - HP I - HP II - RBE - HDBI - HDBC - HDAF

Arrangement 9CB: Models HP I - HP II - RBE - RTE - HDBI - HDBC - HDAF - HPBC

INSTALLATION - OPERATION - MAINTENANCE

CF-04-IOM-24 ISSUED 06/2024

READ AND UNDERSTAND THIS MANUAL PRIOR TO OPERATING OR SERVICING THIS PRODUCT

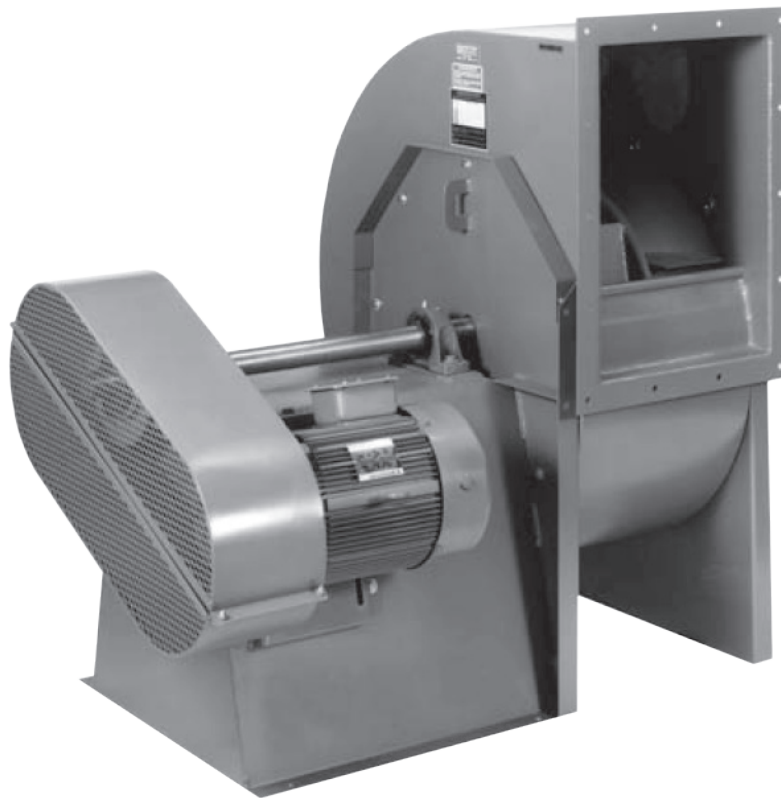

HDBI Centrifugal Fan

Serial Number _____

overview

Note *Read entire manual, including “Initial Unit Startup” before attempting to install and operate this equipment.*

Specifications

Serial Number _____ Mfg Date _____

Note: The serial number above is a required reference for ant assistance. It is stamped on the lower nameplate.

Blower Specifications

Model _____ Arrangement _____ Rotation _____ Discharge _____

Wheel Size and Type _____

Blower Performance Data

CFM _____ SP _____ Motor bhp _____

Density _____ Altitude ft _____ Airstream Temperature _____ °F

Fan RPM _____ Maximum Safe Fan RPM _____ **Do Not Exceed this RPM**

Motor Data: (This section is completed only if the motor was supplied by Cincinnati Fan)

hp _____ RPM _____ Voltage _____ Phase _____

Hz _____ Frame Size _____ Enclosure _____ Efficiency _____

If Motor is EXP, Class(es) and Group(s) are _____

Manufacturer's Model Number _____ CFV Part Number _____

Drive Data:

Fan Sheave _____ Motor Sheave _____ Belts _____

No. of Grooves _____ Fixed Speed Size Adjustable Speed

Note *All Cincinnati Fan products are packaged to minimize any damage during shipment. The freight carrier is responsible for delivering all items in their original condition as received from Cincinnati Fan. The individual receiving this equipment is responsible for inspecting this unit for any obvious or concealed damage. If any damage is found, it should be noted on the bill of lading before the freight is accepted and the receiver must file a claim with the freight carrier.*

Long Term Storage Notice

If this blower will not be installed and put into operation within 30 days, refer to the **Long Term Storage** Instructions on page 27. Failure to follow all applicable long term storage instructions, will void your warranty. This blower should be stored indoors in a clean, dry location.

contents

General.....	4
- Unpacking and Handling	4
- Safety Instructions and Accessories	4
Installation.....	6
- Vibration.....	6
- Mounting Methods	6
- Duct Work Connections	7
- Safety Guards.....	7
- Dampers and Valves	8
- Set Screw and Taper-lock Bushing Torque.....	8
- Blower Bearings	9
- V-Belt Drives.....	9
- V-Belt Installation.....	9
Electrical.....	12
- Disconnect Switches.....	12
- Motor	12
- Maximum Speed and Speed Controllers.....	14
Initial Unit Startup	15
- Pre-Startup and Post-Startup Checks	15
- Vibration.....	17
Routine Inspection and Maintenance	19
- Hardware.....	19
- Motor or Blower Bearing Lubrication	19
- Wheel Balance.....	20
- Vibration.....	21
- Blower Shaft or Bearing Replacement.....	22
- Dampers and Valves	24
- Safety Equipment and Accessories.....	24
Ordering Replacement Parts	25
Troubleshooting.....	25
Long Term Storage	27
Warranty, Limits of Liability, Responsibility and Returns.....	29
Parts Drawing	31

Note

The following defined terms are used throughout this manual to bring attention to the presence of hazards of various risk levels, or to important information concerning the life of the product.

Warning

Indicates presence of a hazard which can cause severe personal injury, death or substantial property damage if ignored.

Caution

Indicates presence of a hazard which will or can cause personal injury or property damage if ignored.

Note

Indicates special instructions on installation, operation or maintenance which are important but not related to personal injury hazards.

general

Receiving

Unpacking

Be careful not to damage or deform any parts of the blower when removing it from the packaging container. All the packaging material should be kept in the event the blower needs to be returned.

Handling

Handling of the blower should be performed by trained personnel and be consistent with all safe handling practices. Verify that all lifting equipment is in good operating condition and has the proper lifting capacity. The blower should be lifted using well-padded chains, cables or lifting straps with spreader bars. Lifting eye locations are provided in the blower base. **Never** lift the blower by an inlet or discharge flange, blower or motor shaft, motor eye bolt, or any other part of the blower assembly that could cause distortion of the blower assembly.

Safety Instructions and Accessories

Safety Instructions:

All installers, operators and maintenance personnel should read AMCA Publication 410-96, *Recommended Safety Practices for Users and Installers of Industrial and Commercial Fans*. This manual is included with the blower.

Sound

Some blowers can generate sound that could be hazardous to personnel. It is the responsibility of the user to measure the sound levels of the blower and/or system, determine the degree of personnel exposure, and comply with all applicable safety laws and requirements to protect personnel from excessive noise.

Air Pressure and Suction

In addition to the normal dangers of rotating machinery, the blower can present additional hazards from the suction or pressure created at the blower inlet or discharge.

Suction at the blower inlet can draw materials into the blower where they become high velocity projectiles at the discharge and cause severe personal injury or death.

It can also be extremely dangerous to persons in close proximity to the inlet or discharge as the forces involved can overcome the strength of most individuals.

Warning

general

⚠ Caution

Never operate a blower with a non-ducted inlet and/or discharge. If the blower inlet and/or discharge is non-ducted, it is the users responsibility to install an inlet and/or discharge guard.

Temperature

Many blowers, blower components and all motors operate at temperatures that could burn someone if they come in contact with them. If this potential hazard could exist in your installation, steps must be taken by the user to protect anyone from coming in contact with this equipment.

Spark Resistance: Per AMCA Standard 99-0401-86 and ISO 13499

⚠ Warning

No guarantee of any level of spark resistance is implied by spark resistant construction. It has been demonstrated that aluminum impellers rubbing on rusty steel can cause high intensity sparks. Air stream material and debris or other system factors can also cause sparks.

Safety Guards

All moving parts must be guarded to protect personnel. Safety requirements can vary, so the number and types of guards required to meet company, local, state and OSHA regulations must be determined and specified by the actual user or operator of the equipment.

⚠ Caution

Never start any blower without having all required safety guards properly installed. All blowers should be checked on a regular schedule, for missing or damaged guards. If any required guards are found to be missing or defective, the power to the blower should be immediately turned off and locked out in accordance with OSHA regulations. Power to the blower should NOT be turned back on until the required guards have been repaired or replaced.

This blower can become dangerous due to a potential "windmill" effect, even though all electrical power has been turned off or disconnected. The blower wheel should be carefully secured to prevent any rotational turning before working on any parts of the blower/motor assembly that could move.

Access or Inspection Doors

⚠ Caution

Never open any access or inspection doors while the blower is operating. Serious injury or death could result from the effects of air pressure, air suction or material that is being conveyed. Disconnect or lock out power to the blower and let the blower wheel come to a complete stop before opening any type of access or inspection door.

installation

Vibration

Before any mounting method is selected, the user should be aware of the effects vibration will have on the blower, motor and other parts. Improper blower installation can cause excessive vibration causing premature wheel and/or motor failure, that is not covered under warranty. Vibration eliminator pads, springs or bases should be properly installed to prevent any blower vibration from transmitting to the foundation or support structure.

⚠ Caution

Shut the blower down immediately if there is any sudden increase in vibration.

Mounting Methods

Floor Mounted Units

Centrifugal blowers should be mounted on a flat, level, concrete foundation weighing 2-3 times the weight of the complete blower/motor assembly. It is recommended that the foundation be at least 6" larger than the base of the blower. The foundation should include anchor bolts such as shown in **Figure 1**. Place the blower over the anchor bolts and shim under each bolt until the blower is level. After shimming, flat washers, lock washers and lock nuts should be tightened at each anchor bolt. Any gaps between the blower base and the foundation should be grouted. If the blower will be sitting on some type of vibration pads or mounts, follow the recommended mounting procedures supplied with the vibration elimination equipment.

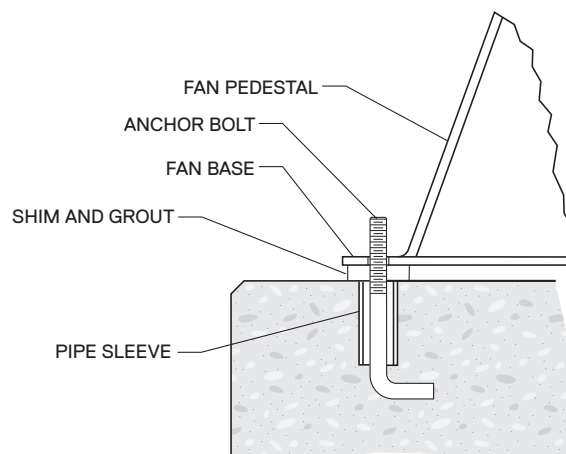

Figure 1

Elevated Units

Improper mounting of elevated blowers can cause vibration problems. The structure that the blower/motor assembly will be mounted on must be strong

installation

enough to support at least 3 times the weight of the entire blower/motor assembly. An insufficient support will cause excessive vibration and lead to premature wheel and/or bearing failures. Bracing of the support structure must be sufficient enough to prevent any side-sway. The entire structure should be welded at all connection joints to maintain constant alignment.

Warning

The improper design of an elevated platform structure could result in a resonant condition, and consequently, cause a life threatening, catastrophic, structural failure.

Duct Work Connection

All duct connections to the blower should include flexible connectors between the ducting and the blower inlet and/or discharge. This will eliminate distortion, noise and vibration from transmitting to the duct and building. The connectors should be selected to handle the operating conditions for air volume and pressure that the blower will produce. All ducting or accessories, added by the user, should be **independently supported**. **Do Not** use the blower assembly to support any additional weight. Inlet and/or discharge duct elbows should be located a minimum 2 blower wheel diameters from the blower. Any duct elbows located closer than 2 wheel diameters to the blower inlet or discharge **Will** reduce the air performance and blower efficiency. Any duct elbows near the blower discharge should be in the same rotational direction as the blower rotation.

Non-Ducted Blower Inlet: Any blower with no ducting on the inlet must have an inlet guard. The blower should be located so the blower inlet is, at least, one wheel diameter away from any wall or bulkhead to eliminate a reduction in air flow.

Non-Ducted Blower Discharge: Any blower with no ducting on the discharge **must** have a discharge guard.

Safety Guards

Cincinnati Fan offers guards, as optional, to keep your blower in compliance with OSHA safety regulations. These include inlet or discharge guards, shaft/bearing guards and belt guards. Arrangement 9 and 9CB blowers come with belt guards as standard. Any blowers built with high temperature construction, a heat slinger guard is standard. It is the responsibility of the user to make sure this blower meets all local, state and OSHA safety regulations. If you have a specific guard requirement not covered by OSHA, please contact the local Cincinnati Fan sales office for assistance.

installation

Dampers and Valves (airflow control devices)

If the blower is supplied with any type of air flow control device, it should be closed before initial startup of the blower to minimize overloading of the motor. Any airflow control device, with bearings, should be maintained in accordance with the manufacturers instructions. Any air flow control device, with an automatic control mechanism, should be adjusted per the manufacturers recommendations.

Set Screw and Taper-Lock Bushing Torque Values

All blower wheel set screws are tightened to the proper torque prior to shipment. Some wheels may have taper-lock hubs and split, taper-lock bushings to secure the wheel to the blower shaft.

Note

Check all set screw or taper-lock bushing torques. Forces encountered during shipment, handling, rigging and temperature can affect factory settings. For correct torque values, see Tables 2 and 3.

Table 1

Diameter and Number of Threads/Inch	Hex Wrench Size (across flats)	Required Torque in·lb _f
1/4-20	1/8"	65
5/16-18	5/32"	165
3/8-16	3/16"	228
7/16-14	7/32"	348
1/2-13	1/4"	504
5/8-11	5/16"	1104

Table 2

Taper-Lock Busing Size	Required Torque in·lb _f
H	95
B	192
P	192
Q	350
R	350

⚠ Caution

Set screws should never be used more than once. If the set screws are loosened, they must be replaced. Use only knurled, cup-point, set screws with a nylon locking patch.

installation

Blower Bearings

The blower bearings have set screws to lock the bearings onto the blower shaft. The set screws should be tightened to the torque levels as shown in **Table 1**. Blower bearings should be lubricated in accordance with the bearing manufacturer's recommendation and with the same type of grease. See **Motor and Blower Bearing Lubrication**. Bearings are pre-lubricated at the factory. The blower shaft/bearing guard (if included) should only be removed for inspection **before** startup and during inspection or maintenance, but only after the power to the motor has been turned off and locked out. **The blower shaft/bearing guard Must be replaced before the power is turned back on.**

V-Belt Drive

If Cincinnati Fan supplied the belts and sheaves (drives package), they were carefully selected for the specific operating conditions supplied to us by the customer.

Warning

Changing any of the v-belt drive component selections, supplied with the blower, could result in unsafe operating conditions which could cause equipment failure, personal injury and death.

If the user is supplying the sheaves and/or belts, it is their responsibility to make the correct component selections for the specific operating conditions. Their selection must also **not allow** the blower to exceed its maximum safe speed or hub load. If you do not know the maximum safe speed or hub load for this blower, **do not** make any drive selection without first consulting Cincinnati Fan or the sales office for your area. Timing belts should never be used on blowers. If you are replacing belts and/or sheaves, checking belt tension or proper alignment, **Figure 2** and **Assembly Steps**. Sheave set screws or taper-lock bushing bolts should be tightened to the torque values as indicated in **Tables 1 and 2**.

V-Belt Drive Installation

Power to the motor must be turned off and locked out, before inspecting, installing or servicing any components of the drives.

If installing new belts, inspect and replace any worn or damaged sheaves, bearings or shafts while the power is turned off and locked out. This will eliminate additional down time later to replace any other parts that were worn or defective.

If installing a complete set of new drives, the most critical steps of the installation are alignment of the sheaves and belt tension. Misaligned sheaves and/or improper belt tension will cause excessive fan vibration and result in premature belt and /or bearing failure.



installation

The blower and motor shafts must be parallel and the sheaves must be in line with each other. See **Figure 2**.

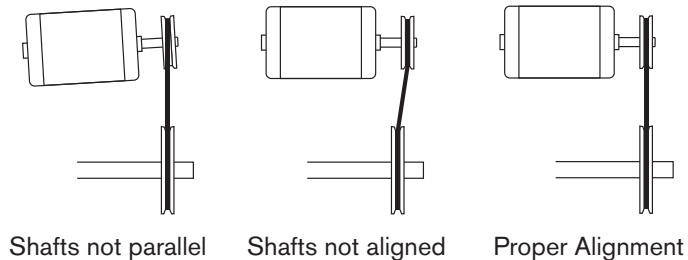

Figure 2

Assembly

1. Remove belt guard and open shaft access holes. Remove the protective coating from the blower and motor shafts.
2. The adjustable motor slide base should be used for belt tension adjustment. Adjust the motor on the slide base by turning the adjustment bolt(s) in the end of the slide base, so the motor is as close to the blower as possible.

Note

The 4 nuts that secure the motor feet onto the motor slide base should be loosened just enough so the motor will slide along the slide base before you loosen or tighten the belt tension adjustment bolt(s).

3. If replacing the belt(s) and/or sheaves, remove belt(s) from sheaves and then loosen the sheaves set screws or taper-lock bushings to remove the sheaves.
4. Check the blower and motor shafts for any nicks or burrs. Remove any burrs with a file or emery paper.
5. Slide the new sheaves onto the blower and motor shafts. **Do not** drive or pound the sheaves on as this may damage the blower and/or motor bearings.
6. Check the blower and motor shafts to make sure they are parallel and aligned as shown in **Figure 2**.
7. Place the belt(s) over the sheaves. **Do not** force, pry or “roll” the belts, as this could damage the cords in the belt(s). If there is more than one belt, all the belts should be a “matched set”.
8. Align the blower and motor sheaves with a straight-edge or string as shown in **Figure 3**. If the sheaves are not the same width, align by sight. For more precise methods, consult your local drives dealer.

Note

Any sheave with a taper-lock bushing will slide a little on the shaft as the bolts are tightened. You will need to compensate for the sliding before performing Step 9.

installation

9. Tighten the set screws in the sheaves or the bolts in the taper-lock bushings to the correct torque values as indicated in **Tables 1** and/or **Table 2**.
10. Adjust the motor slide base until the belts appear to be snug, then repeat Step 6.
11. Tighten the 4 nuts holding the motor feet onto the motor slide base, then repeat Step 6.

⚠ Caution

Before attempting steps 12 and 15, make sure the area around the blower is safe and secured so no one can get near the blower and possibly get injured when it is started.

12. Unlock power to the motor and run the blower for 15-20 minutes to allow belts to “seat” properly. Then turn off and lock out power to the motor.
13. Loosen the four bolts in the side of the motor adjustment base and readjust the belt tension. Final belt tension should be checked with a “tensioning gauge”.
14. Tighten the four nuts in the side of the motor adjustment base.
15. Unlock power to the motor and run the blower for eight hours. The belts should be running as shown in **Figure 4** below. If not, repeat steps 13 and 14 after you have turned off and locked out power to the motor.
16. Turn off and lock out power to the motor, reinstall belt guard and shaft guard, unlock power to motor and run the blower.

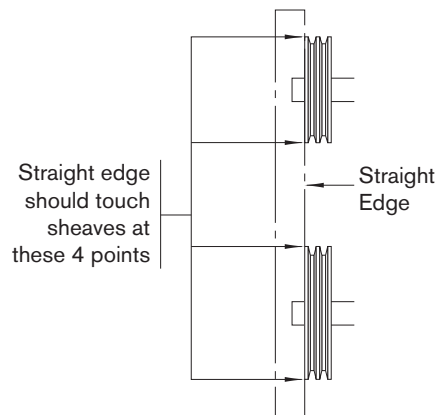

Figure 3

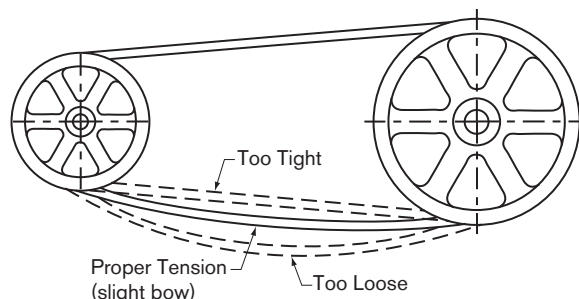

Figure 4

installation

17. After running the blower for 24 hours, turn off and lock out power to the motor. Then, remove belt guard. Repeat Steps 13 through 16 above.
18. After running the blower for 100 hours, lock out power to the motor, remove belt guard and repeat steps 13 through 16. Repeat this periodically, but never more than a one year period.

Electrical

Disconnect Switches:

All blower motors should have an independent disconnect switch located in close visual proximity to turn off the electrical service to the blower motor. **Disconnects must be locked out in accordance with OSHA “lock out-tag out” procedures any time inspection or maintenance is being performed on the blower and/or motor assembly.** The “lock out-tag out” procedure should be performed by a licensed electrician or authorized personnel.

All disconnects should be sized in accordance with the latest NEC codes (National Electric Codes) and any local codes and should be installed only by a licensed electrician. “Slow blow” or “time delay” fuses or breakers should be used since the initial start-up time for the blower motor, although rare, can be up to 10 seconds.

Motor

All wiring connections, inspection and maintenance of any motor must be performed by a licensed electrician in accordance with the motor manufacturers recommendations, all electrical codes and OSHA regulations. Failure to properly install, make wiring connections, inspect or perform any maintenance to a motor can result in motor failure, property damage, explosion, electrical shock and death.

1. **Do Not connect or operate a motor without reading the motor manufacturers instructions supplied with the motor.** The basic principle of motor maintenance is: Keep the motor clean and dry. This requires periodic inspections of the motor. The frequency of the inspections depends on the type of motor, the service and environment it will be subjected to and the motor manufacturers instructions.
2. **Cleaning:** Cleaning should be limited to exterior surfaces only. Follow motor manufacturers cleaning instructions.
3. **Lubrication:** Most small motors have sealed bearings that are permanently lubricated for the life of the motor. Some larger motors have grease plugs

Warning

installation

that should be replaced with grease fittings to perform re-lubrication. These motors, or any motor with grease fittings, should be lubricated in accordance with the motor manufacturers recommendations. Lubrication frequency depends on the motor horsepower, speed and service. **Be sure** you use compatible grease and **Do not** over grease.

4. **Location:** If the motor will be outside and subjected to the weather, it is recommended that a weather cover be installed to keep rain and snow off of the motor. No motors are guaranteed to be “watertight”. Be careful to allow enough openings between the motor and the motor cover to let the motor “breathe”. If the back end of the motor is covered, the cover should be no closer than 3" to the back of the motor for proper ventilation.
5. **Wiring Connections:** All wiring connections should be made for the proper voltage and phase as shown on the motor nameplate. Connections should follow the motor manufacturers recommendations as shown on the wiring schematic. This wiring diagram will be located on the outside of the motor, inside of the motor conduit box or on the motor nameplate. Reversing some wires might be necessary to get the correct blower rotation.
6. **Motors with Thermal Overload Protection:** If a motor is equipped with thermal overloads, the thermal overload must be wired per the wiring schematic to be operable. There are three types of thermal overloads:

Automatic: These will automatically shut the motor down if the internal temperature exceeds the design limits.

Caution

Make sure you lock out the power to the motor before inspecting any motor with automatic thermals, when the thermals cool down, they will allow the motor to automatically start up again, unless you have locked out the power to the motor.

Manual: These motors will have a button on them. If the motor overheats, it will shut down. After you have inspected the motor and eliminated the over-heating problem, you will need to “reset” it by pushing the button. Lock out the power Before inspecting the motor.

Thermostats: This type of thermal is a temperature sensing device **only**. If the motor overheats, the thermostats will open or close (depending on the type) and send a “signal” to the electrical box. **They will not turn the motor off**. These are pilot circuit devices that must be connected to the magnetic starter circuit.

7. **Explosion Proof Motors:** No motor is explosion proof. Explosion proof motors are designed so if there is an explosion within the motor, the explosion will be contained inside the motor and not allowed to get out to



installation

the atmosphere. All explosion proof motors must be selected based on the atmosphere and/or the environment the motor will be operating in. Explosion proof motors are designed, rated, and labeled for their operating conditions based on Classes, Groups and T Codes. The Class, Group and T code of an EXP motor must be selected based on the atmosphere and/or environmental conditions the motor will be operating in. Consult the NEC (National Electric Code) and the NFPA (National Fire Protection Association) for the proper EXP motor Class, Group and T Code required for your specific application and location.

Warning

If an explosion proof motor is used in an area containing volatile liquids, gases, fumes or dust for which the motor was not designed to operate in, an explosion and/or fire may occur.

Note

All EXP motors have some type of thermal overload as required by UL (Underwriters Laboratories).

All EXP motors are required to have the UL and CSA (Canadian Standards Association) listing numbers on the motor name plate or on a separate plate attached to the motor. The Class, Group and T Code the motor is designed for must also be listed.

8. **Normal Motor Operating Temperatures:** The normal operating temperature of a fully loaded, open type, electric motor operating in a 70°F (21°C) ambient temperature is 174°F (79° C)

Maximum Blower Speed and Motor Speed Controllers:

If you will be using any type of motor speed controller with this blower, do not exceed the maximum safe blower speed. Installing and using a speed control device requires special training and certification as required by the speed control manufacturer. See the manufacturers instructions for proper use, installation and wiring connections for the maximum speed settings. It may be necessary to “block out” some speeds to eliminate a resonant vibration problem. The maximum safe blower speed is shown on the data sheet shipped with the blower. If you have lost the data sheet, contact Cincinnati Fan or the sales office for your area. You must have the serial number from the blower name plate for us to determine the maximum safe blower speed. Cincinnati Fan will only extend the motor manufacturers warranty, when used with a speed controlling device, if the motor has the words **“Inverter Duty”** marked on the motor name plate. If the motor does not have “Inverter Duty” marked on the motor name plate, and you have a motor failure, you will be required to contact the motor manufacturer for any service or warranty claims.

operation

Pre-Startup and Post-Startup Check (Check blocks as each step is completed. Retain for you records)

Note

Failure to complete and document all the following Pre-Startup checks, Post-Startup checks and Vibration checks, could void all warranties.

Pre-Startup Check completed by: _____ Date _____

Eight Hour Post-Startup Check completed by: _____ Date _____

Three-Day Post-Startup Check completed by: _____ Date _____

Make sure power to the motor is locked out before starting pre-start or post-start checks.

- 1 Check all blower, foundation and duct work hardware to make sure it is tight.
- 2 Check all blower wheel, sheave and bearing set screws to make sure they are tight per **Table 1**.
- 3 If the blower wheel/sheaves have a taper-lock bushing, make sure the bolts are tightened per **Table 2**.
- 4 Make certain there is no foreign material in the blower or duct work that can become a projectile.
- 5 Make sure any inspection doors in the blower housing or duct work are securely bolted or locked.
- 6 Ensure all electrical power components are properly sized and matched for your electrical system.
- 7 Check the blower wheel, by turning the wheel by hand to ensure it rotates freely.
- 8 Check sheaves for proper alignment and belts for proper tension. See **V-Belt Drive Installation**.
- 9 Check that all required guards are properly secured.
- 10 Any dampers should be fully opened, then fully closed to make sure there is no binding or interference.
- 11 If your blower is mounted on an elevated support structure, make sure the structure is welded at all the joint connections, welds have not cracked and the structure is properly braced to prevent “side sway”.
- 12 Close any dampers to minimize the load on the motor, especially on blowers with high temperature construction. **Never** subject a **cold** blower to a **hot** gas stream. If the blower will be handling “hot gases” greater than 150°F (65°C) it is imperative that the blower be subjected to a gradual rate of temperature increase, not to exceed 15°F/minute (8°C/minute). The same temperature limits are also important when the blower is experiencing a drop in temperature until the temperature drops down to 150°F (65°C). Only, when the entire blower has reached an equilibrium temperature of 150°F (65°C), or less, should the power be turned off.
- 13 Make sure the power source connections to the blower motor are per the motor manufacturer’s instructions.
- 14 Make sure the blower wheel is stationary prior to startup. **Starting a blower with a wheel that is rotating backwards can cause wheel damage.**
- 15 Apply power to the blower motor momentarily (bump start) to check for proper blower wheel rotation. If the blower is rotating in the wrong direction, reconnect the motor leads per the motor manufacturer’s wiring schematic. **Blower rotation is determined by viewing the blower from the motor side of the blower, NOT from the inlet side.** After reconnecting the leads, repeat this step. See **Figure 5**.



operation

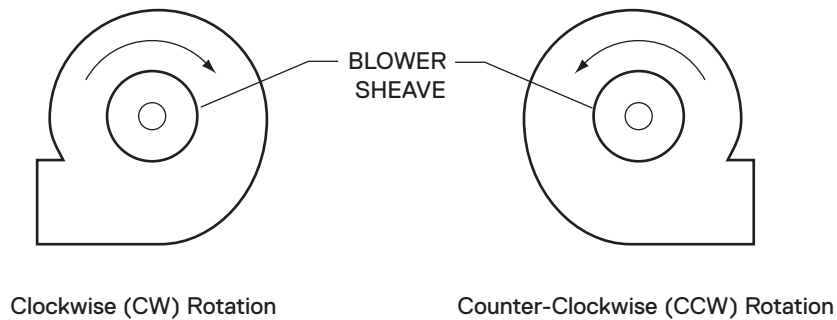

Figure 5

Pre-Startup Check completed by: _____ Date _____

Eight Hour Post-Startup Check completed by: _____ Date _____

Three-Day Post-Startup Check completed by: _____ Date _____

- 16 Apply power to the motor and let it come up to full speed. Turn off the power. Look and listen for any unusual noise or mechanical abnormality while the blower wheel is still spinning. If any are noticed, lock out the power, wait for the blower wheel to come to a complete stop, locate the cause and correct it.
- 17 Unlock power to the motor and run the blower for 15-20 minutes to allow belts to “seat” properly. Turn off and lock out power to the motor.
- 18 Remove the belt guard and check the belt tension with a “belt tensioning gauge”. If the belts are too loose, loosen the 4 nuts holding the motor feet on the motor slide base and re-adjust the belt tension
- 19 Tighten the 4 nuts in the motor feet.
- 20 Unlock power to the motor and run the blower for 8 hours. The belts should be running as shown in Figure 4. If not, repeat steps 18 and 19 after you have turned off and locked out power to the motor.
- 21 When belts are running properly, turn off and lock out power to the motor. Re-install belt guard.
- 22 Unlock power to the motor and run the blower.
- 23 Measure, record and keep the following motor data for future reference and comparison: **(Single phase motors will only have L1 and L2 leads)**
Amperage draw on each motor lead: L1 _____ L2 _____ L3 _____
 (Running amps **should not** exceed the motor name plate amps for the voltage being operated on).
Voltage coming to motor leads: L1 _____ L2 _____ L3 _____
 (Should be about the same input voltage on all leads)
- 24 After running the blower for 24 hours, turn off and lock out power to the motor, remove belt guard and repeat steps 17 through 20.
- 25 Repeat step 23 after 100 hours and periodically after that but never more than a one year period.

operation

Vibration

The blower was balanced at the factory to comply with ANSI/AMCA Standard 204-05, Category BV-3. However, rough handling in shipment and/or erection, weak and/or non-rigid foundations, and misalignment may cause a vibration problem after installation. After installation, the vibration levels should be checked by personnel experienced with vibration analysis and vibration analysis equipment.

⚠ Caution

The blower Should Not be operated if the vibration velocity of the blower exceeds 0.40 inches per second, filter out, if the blower is rigidly mounted. If the blower is mounted on isolators or on an isolator base, it should not be operated if the vibration velocity of the blower exceeds 0.65 inches per second, filter out.

Vibration readings for belt driven blowers should be taken at the top, sides and end as per **Figure 6**. They should also be taken on the top, sides and ends of the blower bearings as per **Figure 7**. After you have taken vibration readings, record them in **Table 3** and keep for future comparison.

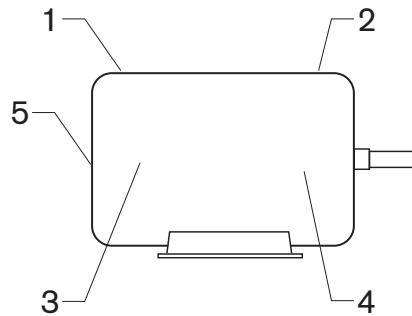

Figure 6

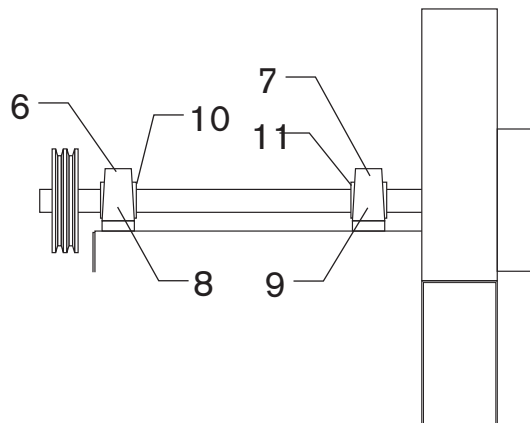

Figure 7



operation

Table 3 – Vibration Meter Probe Positions											
	1	2	3	4	5	6	7	8	9	10	11
A											
B											
C											

A–Pre-Startup Check completed by: _____ Date _____

B–Eight Hour Post-Startup Check completed by: _____ Date _____

C–Three-Day Post-Startup Check completed by: _____ Date _____

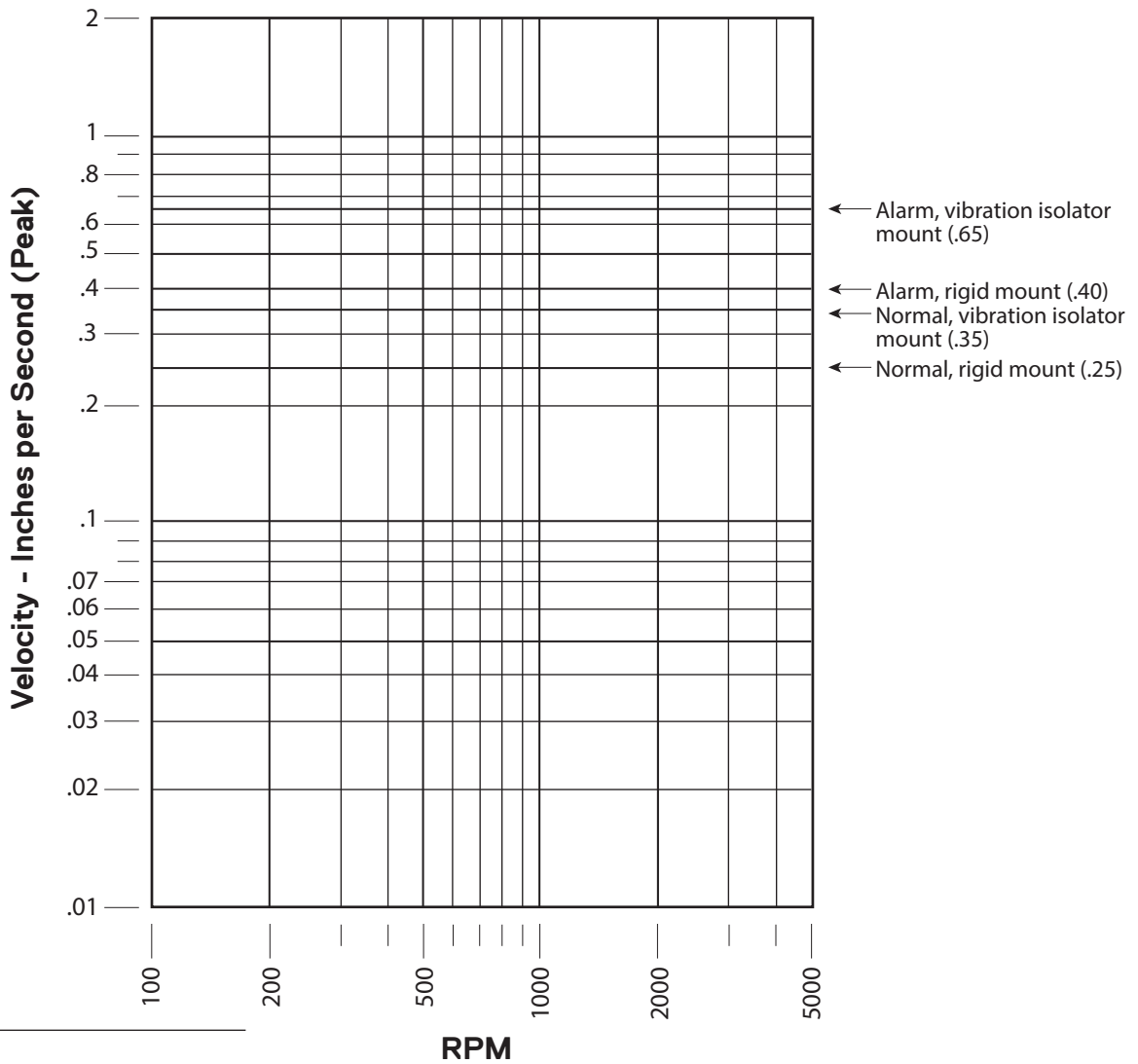

Figure 8

Vibration Severity Graph

maintenance

Routine Inspection and Maintenance

Periodic inspection of all the blower parts is the key to good maintenance and trouble-free operation. The frequency of inspections must be determined by the user and is dependent upon the severity of the application, **but**, it should **never** exceed a 12 month period. The user should prepare an inspection and maintenance schedule and make sure it is adhered to.

⚠ Caution

Before starting any inspection or maintenance, be sure blower is turned off, power is locked out and the blower wheel has been carefully secured to prevent wind milling. If the operating conditions of the blower are to be changed (speed, pressure, temperature, etc.) consult Cincinnati Fan or our sales office in your territory to determine if the unit will operate safely at the new conditions.

Hardware

All blower and foundation hardware should be checked to make sure it is tight. All set screws or taper-lock bushing bolts should be tightened to the torque values shown in **Tables 2** and **3**.

Note

If any set screws have become loose, they must be replaced. Never use set screws more than once. Replace with knurled, cup-point set screws with a nylon locking patch.

Motor and Blower Bearing Lubrication

Most smaller motors have sealed bearings that never require relubrication for the life of the motor. For any motors with grease fittings, consult the motor manufacturers recommendations with reference to the lubrication frequency and the type of grease that should be used.

Do not over grease the motor bearings. Generally, 1-2 shots should be enough. Use a hand operated grease gun at no more than 40 psi. If possible, **carefully** lubricate the motor bearings while the motor is running.

Blower Bearings

Blower bearings should be re-lubricated per the chart below for all clean and dry applications where the ambient temperature or blower air temperature is -20°F (-29°C) up to 120°F (49°C). If your application is dirty, moisture laden air, or is outside the temperature limits stated previously, consult the bearing manufacturer for the proper grease type and lubrication frequency. The chart below is affixed to every belt driven blower base.



maintenance

Note

For high temperature applications that require high temperature grease in the blower bearings, a chart similar to below will also specify that Only Dow Corning DC44 (silicone based) high temperature grease should be used.

Do not over grease the blower bearings. Generally, 1-2 shots should be enough. Use a hand-operated grease gun at no more than 40 psi. **If possible, carefully lubricate the blower bearings while the blower is running.**

Fan Bearings are Pre-Lubricated and Ready for Use Recommended Lubrication Frequency in Months						
Fan Operating Speed RPM	Fan Shaft Diameter (OD)					
	1/2" to 1"	1 1/8" to 1 1/2"	1 5/8" to 1 15/16"	2" to 2 1/2"	2 11/16" to 3 3/16"	3 7/16" to 3 15/16"
Up to 500	6	6	6	6	5	5
500 - 1000	6	6	6	5	4	4
1000 - 1500	6	5	5	4	3	2
1500 - 2000	5	5	4	3	2	1
2000 - 2500	5	5	3	2	2	
2500 - 3000	5	4	2	2	1	
3000 - 3500	4	3	2	1		
3500 - 4000	3	3	1			
4000 - 4500	2	2	1			
4500 - 5000	2	1				

The above lubrication frequencies are based on the fan bearings operating in a clean and dry environment from -20°F (-29°C) up to 120°F (49°C). For hostile, moisture laden environments and/or temperatures below -20°F (-29°C) or above 120°F (49°C), consult the bearing manufacturer for the proper grease type and recommended lubrication frequencies.

If possible, carefully lubricate the bearings while the fan is running.

Add grease until a slight bead appears at the bearing seals. **Do not** over grease.

Generally, 1-2 shots with a hand grease gun that has a maximum pressure rating of 40 psi. **Over greasing bearings will cause them to run hot.**

The type of grease you use **must be** compatible with the grease already in the bearings.

Wheel Balance

All blower wheels are balanced at the factory. It is not uncommon that additional "trim balancing" is required after the blower is assembled. Trim balancing of the blower assembly, in the field, is typically always necessary for all replacement wheels. After any wheel is installed, the final balance of the entire blower assembly should be checked. Refer to the **Vibration Section** and **Figure 8**.

maintenance

Airstream material or chemicals can cause abrasion or corrosion of the blower parts. This wear is generally uneven and, over time, will lead to the wheel becoming unbalanced causing excessive vibration. When that happens, the wheel must be rebalanced or replaced. Other airstream components should also be inspected for wear or structural damage and cleaned or replaced if necessary. **After cleaning any blower wheel, it should be balanced and then “trim balanced” on the blower shaft.**

Balancing a Blower Wheel

There are three ways to balance a blower wheel:

1. **Grinding of material for cast aluminum wheels.** If grinding on the wheel to remove material, be very careful not to grind too much in one area which could affect the structural integrity of the wheel.
2. **Add balancing weights for fabricated aluminum, steel or stainless steel wheels:** Balance weights should be rigidly attached to the wheel at a location that will not interfere with the blower housing nor disrupt air flow. They should (if at all possible) be welded to the wheel. When trim balancing the wheel, on the blower shaft, be sure to ground the welder directly to the wheel. Otherwise, the welding current will likely pass through the blower shaft and damage the blower and/or motor bearings.
3. **Forward curved wheels, Model LM only** (also known as squirrel cage or multivane wheels): These wheels have balancing clips attached to individual blades around the wheel. That is the only proper way to balance this type of wheel.

Note

Removing any Forward Curved, Backward Inclined or Airfoil wheel from the blower requires special attention when reinstalling the wheel back into the blower housing. Make sure you reinstall the wheel so the proper wheel-to-inlet clearance is maintained. Failure to do this will affect the blower's airflow (CFM), and/or static pressure (SP) capabilities and efficiency. Consult Cincinnati Fan or our local sales office for your area for assistance if necessary.

Vibration

As mentioned previously in this manual, excessive vibration can cause premature motor failure that could lead to catastrophic failure of the blower. After performing any routine maintenance, the vibration readings should be taken. New readings should be taken (maximum every 12 months) and compared to the readings you recorded in **Table 4** during the initial startup. If any major



maintenance

differences are present, the cause should be determined and corrected before the blower is put back into operation.

The most common causes of vibration problems are:

- Wheel unbalance
- Bearing Failure
- Foundation stiffness
- Mechanical looseness
- Misaligned sheaves and/or belts
- Poor blower inlet and/or discharge conditions

Blower Shaft and Bearing Replacement

The blower shaft and bearings for Cincinnati Fan blowers are carefully selected to match the maximum load and operating conditions for each specific blower model. If the instructions in this manual and those provided by the bearing manufacturer are followed, you should not need to replace the bearings for many years.

When the bearings are replaced, it is strongly recommended that the blower shaft also be replaced at the same time. Use the following applicable steps when replacing the blower bearings and/or blower shaft.

1. **Lock out the power source to the motor and let the wheel come to a complete stop.**
2. If necessary, disconnect the inlet and/or discharge duct work from the blower.
3. Remove the inlet side of the blower housing.
4. Measure and record the location of the blower wheel on the shaft, then remove the locking hardware in the wheel hub.
5. **Carefully** remove the wheel.
6. Remove the blower shaft/bearing guard and belt guard (if applicable).
7. Loosen the 4 bolts holding the motor onto the motor adjustment base.
8. Loosen the tension adjustment bolt(s) on the end of the motor adjustment base.
9. Remove the belt(s), loosen the blower sheave set screws or taper-lock hub bolts and remove the blower sheave.
10. Disconnect any lube lines to the bearings (if applicable).
11. On most models, there is a rust preventative coating that was applied to the blower shaft before shipment. Remove this coating at all areas with a solvent or degreaser.
12. Measure and record location between bearings and distance from the bearings to each end of the shaft.

maintenance

13. Remove the hardware holding the bearings on the blower shaft. Then, remove blower shaft from bearings.
14. Remove the hardware holding the bearings on the blower base. Be careful not to change the location of any bearing pads that are under the bearings.
15. When replacing the bearings, it is strongly recommended that the blower shaft also be replaced. If using the same blower shaft, file down all the setscrew marks on the shaft.
16. Install new bearings onto the new blower shaft or onto the original shaft. Be sure the bearing locking collars are facing each other and the set screws are in line with each other.
17. Place the blower shaft/bearing assembly onto the blower base with any bearing pads located under each bearing as were under the original bearings.
18. Install the hardware to bolt the bearings to the blower base, **Do Not** tighten at this time.
19. Slide the blower shaft into the bearings so the dimensions match those taken in Step 12.
20. Tighten the bearing mounting bolts that hold the bearings on the blower base.
21. Using a soft-faced mallet, gently tap on the blower shaft in between the two bearings while turning the blower shaft by hand. This will “seat” the bearing races. The shaft **must turn** freely.
22. Tighten the set screws in both bearings. **Note:** If there are 2 set screws per bearing, make sure you tighten the set screws in line with each other on each bearing and then the other set screws.
23. Turn the blower shaft again to make sure it turns freely and does not bind.
24. Slide blower sheave onto the blower shaft.
25. Align the blower and motor sheaves and adjust belt tension per the instructions in **V-Belt Drive Installation**. **Note:** Install new shaft key and any sheave set screws.
26. Reconnect any bearing lube lines (if applicable.)
27. While rotating the blower shaft, lubricate blower bearings with fresh grease per instruction in **Motor and Blower Bearing Lubrication**.
28. Install new set screws into the wheel, or taper-lock hub bolts into the hub. **Do not use old screws or bolts.**



maintenance

29. Install the blower wheel onto the blower shaft making sure it is in the same location on the blower shaft as it was originally per the dimension recorded in Step 4.
30. Install new shaft key into the wheel.
31. Turn the wheel by hand to determine if there is any binding of the shaft in the bearings, or if there is any interference between the back plate of the wheel and the blower housing.
32. Tighten the wheel set screw, over the key first, to the torque values in **Table 1**. Next, tighten the set screw onto the blower shaft or, tighten the taper-lock hub bolts per Table 2.
33. Reinstall the blower inlet side housing.
34. Turn the wheel by hand to determine if there is any interference between the wheel and the inlet side of the blower housing.
35. Unlock power to motor and turn on.
36. Let blower run for 10 minutes.
37. Turn off and lock out power to the motor.
38. Check all hardware and set screws to make sure they are tight.
39. Reinstall all safety guards supplied with the blower or by the user, and any duct work connections.
40. Unlock power to motor and turn on.
41. Repeat steps 1, 6 and 38 through 40 (in that order) after 8 hours and again after 1 week.

Dampers and Valves Airflow control device

Turn off and lock out power to the blower motor. Any dampers or valves should be periodically inspected to make sure all parts are still operable within their full range and there is no interference with any other damper or blower components. Any bearings or seals should be checked for their proper function. The manufacturers maintenance instructions should be followed.

Safety Equipment and Accessories

It is the user's responsibility to make sure that any safety guards required by company, local, state and OSHA regulations are properly attached and fully functional at all times. If any guards become defective or non-functional at any time, the power to the blower **must** be turned off and locked-out until complete repairs and/or replacements have been made, installed and inspected by authorized personnel. Any accessories used in conjunction with the blower should also be inspected to make sure they are functioning within their intended

maintenance

limits and design specifications. The manufacturer's maintenance manuals should be referred to for correct maintenance procedures. These accessories include, but are not limited to, the following:

- Shaft seals, inspection doors, vibration isolators or vibration bases, air flow or pressure measuring equipment, hoods, controls, special coatings, silencers, expansion joints, valves, flexible connectors, filters, sheaves and belts.

Replacement Parts

Under normal conditions, you should not need any spare or replacement parts for at least 24 months after shipment from Cincinnati Fan. That does not include any wear due to abrasion, corrosion, excessive temperatures, abuse, misuse, accident or any severe conditions the fan was not designed for.

- If this fan is vital to any process that could cost you lost revenue, we strongly recommend that you keep a blower wheel and motor at your location.
- If this fan is vital for the safety of any people and/or animals, we strongly recommend that you keep a complete blower/motor assembly, as originally ordered, at your location.

To order parts or complete units, contact us for the name of our sales office in your area or locate them on our website at cincinnati.com.

Note

The blower serial number from the blower name plate is required to identify parts correctly.

Troubleshooting

Potential problems and causes listed below are in no order of importance or priority. The causes are only a list of the most common items to check to correct a problem. If you find the cause of a problem, **do not** assume it is the **only** cause of that problem. Different problems can have the same causes.

⚠ Warning

Troubleshooting should only be performed by trained personnel. Any potential electrical problems should only be checked by a licensed electrician. All safety rules, regulations and procedures must be followed.



troubleshooting

Trouble	Cause
Excessive Vibration	Loose mounting bolts, set screws or taper-lock hub bolts, bearings and sheaves
	Misalignment of sheaves, blower bearings or motor
	Worn or corroded blower wheel
	Accumulation of foreign material on blower wheel
	Bent motor or blower shaft
	Worn motor and/or blower bearings
	Worn sheaves and/or belts
	Motor out of balance
	Inadequate structural support
	Support structure not sufficiently cross braced
Airflow (CFM) Too Low	Weak or resonant foundation
	Foundation not flat and level
	Blower wheel turning in wrong direction (rotation)
	Actual system static pressure (SP) is higher than expected
	Motor speed (RPM) too low, incorrect or defective belts and/or sheaves
	Dampers or valves not adjusted properly
	Leaks or obstructions in duct work
	Filters dirty
	Inlet and/or discharge guards are clogged
	Duct elbow too close to blower inlet and/or discharge
Airflow (CFM) Too High	Improperly designed duct work
	Wheel not properly located relative to the inlet bell (LM, HDBI and HDAF models only)
	Actual system static pressure (SP) is lower than expected
	Motor speed (RPM) too high
Motor Overheating	Filters not in place
	Dampers or valves not adjusted properly
	Actual system static pressure (SP) is lower than expected
	Voltage supplied to motor is too high or too low
	Motor speed (RPM) too high or defective motor
Excessive Noise	Air density higher than expected
	Motor wired incorrectly and/or loose wiring connections
	Note – a normal motor will operate at 174°F
	Wheel rubbing
	Worn or corroded blower wheel
	Accumulation of foreign material on blower wheel
	Loose mounting bolts, set screws or taper-lock hub bolts, bearings or sheaves
	Misalignment of blower bearings, sheaves or motor
	Bent motor shaft or blower shaft
	Worn motor and/or blower bearings
Fan Doesn't Operate	Motor out of balance
	Motor and/or blower bearings need lubrication
	Vibration originating elsewhere in system
	System resonance or pulsation
	Inadequate or faulty design of blower support structure
	Blower operating near stall condition due to incorrect system design or installation
	Motor wired incorrectly or loose wiring connections
	Incorrect voltage supply
	Defective fuses or circuit breakers
	Power turned off elsewhere
Defective motor	

information

Long Term Storage

Storage exceeding 30 days after receipt of equipment.

Failure to adhere to these instructions voids all warranties in their entirety.

Note

- Storage site selection:
 - Level, well-drained, firm surface, in clean, dry and warm location. Minimum temperature of 50°F (10°C).
 - Isolated from possibility of physical damage from construction vehicles, erection equipment, etc.
 - Accessible for periodical inspection and maintenance.
- The blower should be supported under each corner of its base to allow it to “breathe”. Supports (2 x 4s, timbers, or railroad ties) should be placed diagonally under each corner.
- If the equipment is to be stored for more than three (3) months, the entire blower assembly must be loosely covered with plastic, **but not tightly wrapped**.
- Initial inspections must be made of the blower components, and immediate corrective action taken if discrepancies are found, to insure adequate protection of the equipment during storage.
 - Blower bearings only should be completely filled with lubricant to minimize the chance of oxidation or rust.
 - Sheave center distance should be reduced to reduce tension on the belts.

- Storage Maintenance:

A periodic inspection and maintenance log, by date and action taken, must be developed and maintained for each blower. See example below. Each item must be checked monthly.

Note

Storage/Maintenance Schedule Log Example	
Action	Date Checked
Reinspect units to insure any protective devices used are functioning properly. Check for scratches in the finish which will allow corrosion or rust to form	
Rotate blower wheel a minimum of 10 full revolutions to keep the moor bearing grease from separating and drying. This is a critical step.	



information

- General Motor Procedure:

If the motor is not put into service immediately, the motor must be stored in a clean, dry, warm location. Minimum temperature of 50°F. (10°C.). Several precautionary steps must be performed to avoid motor damage during storage.

- Use a “Megger” each month to ensure that integrity of the winding insulation has been maintained. Record the Megger readings. Immediately investigate any significant drop in insulation resistance.
- **Do not** lubricate the motor bearings during storage. Motor bearings are packed with grease at the factory. Excessive grease can damage the insulation quality in the motor.
- If the storage location is damp or humid, the motor windings must be protected from moisture. This can be done by applying power to the motor’s space heaters, (if available) while the motor is in storage. If the motor does not have space heaters, storing it in a damp or humid location will, very quickly, cause internal corrosion and motor failure which is not warranted.
- Rotate motor shaft a minimum of 10 full turns each month to keep bearing grease from separating and drying out.

Note

For specific storage instructions, for the actual motor and any accessory parts that were supplied, refer to the manufacturer’s instructions.

information

Limited Warranty

Cincinnati Fan and Ventilator Company (Seller) warrants products of its own manufacture, against defects of material and workman-ship under normal use and service for a period of eighteen (18) months from date of shipment or twelve (12) months from date of installation, whichever occurs first. This warranty does not apply to any of Seller's products or any part thereof which has been subject to extraordinary wear and tear, improper installation, accident, abuse, misuse, overloading, negligence or alteration. This warranty does not cover systems or materials not of Seller's manufacture. On products furnished by Seller, but manufactured by others, such as motors, Seller extends the same warranty as Seller received from the manufacturer thereof. Expenses incurred by Purchaser's in repairing or replacing any defective product will not be allowed except where authorized in writing and signed by an officer of the Seller.

The obligation of the Seller under this warranty shall be limited to repairing or replacing F.O.B. the Seller's plant, or allowing credit at Seller's option.

This warranty is expressly in lieu of all other warranties either expressed or implied including the warranties of merchantability and fitness for a particular purpose and of all other obligations and liabilities of the seller. The purchaser acknowledges that no other representations were made to purchaser or relied upon by purchaser with respect to the quality or function of the products herein sold.

Removal of the Sellers nameplate or any generic fan nameplate containing the fan serial number voids all warranties, either writ-ten or implied. Failure to complete and document all the pre-startup and post startup checks and perform the suggested routine maintenance checks voids all warranties, either written or implied.

information

Limitation of Liability

Notice of any claim, including a claim for defect in material or workmanship, must be given to Seller in writing within 30 days after receipt of the equipment or other products. Seller reserves the right to inspect any alleged defect at Purchaser's facility before any claim can be allowed and before adjustment, credit, allowance replacement or return will be authorized. See RETURNS below. Seller's liability with respect to such defects will be limited to the replacement, free of charge, of parts returned at Purchaser's expense F.O.B. Seller's plant and found to be defective by the Seller.

In no event will seller be liable for special, indirect, incidental or consequential damages, whether in contract, tort, negligence, strict liability or otherwise, including without limitation damages for injury to persons or property, lost profits or revenue, lost sales or loss of use of any product sold hereunder. Purchaser's sole and exclusive remedy against seller will be the replacement of defective parts as provided herein or refund of the purchase price for defective products, at seller's sole option. Seller's liability on any claim, whether in contract, tort, negligence, strict liability or otherwise, for any loss or damage arising out of or in connection with purchaser's order or the products or equipment purchased hereunder, shall in no case exceed the purchase price of the equipment giving rise to the claim.

Responsibly

It is the understanding of the Seller that Purchaser and/or User will use this equipment in conjunction with additional equipment or accessories to comply with all Federal, State and local regulations. The Seller assumes no responsibility for the Purchaser's and/or User's compliance with any Federal, State and local regulations.

Returns

Cincinnati Fan & Ventilator Company assumes no responsibility for any material returned to our plant without our permission. An RMA (Return Material Authorization) number must be obtained and clearly shown on the outside of the carton or crate and on a packing slip. Any items returned must be shipped freight prepaid. Failure to comply will result in refusal of the shipment at our receiving department.

information

Disclaimer

This manual, and all its content herein, is based on all applicable known material at the time this manual was created. **Any parts of this manual are subject to change at any time and without notice.**

If any statements, diagrams and/or instructions contained herein, for components not manufactured by the Seller, conflict with instructions in the manufacturer's manual (i.e.: motors, bearings, dampers, etc.), the instructions in the manufacturer's manual, for that component take precedent.

Should you want the latest version of this manual, please contact us or our sales office for your area. Or, you can print a current version by going to our website at: cincinnati-fan.com.

Parts Drawing

Cincinnati Fan manufactures many models and arrangements with special variations. For that reason, the maintenance manuals contained on our website do not include a parts drawing nor the completed blower or fan specifications on page 2.

For the parts drawing of all the standard components and specifications for the specific blower or fan that you have, please contact our local Cincinnati Fan sales office for your area.

You will need to give them the serial number shown on the blower or fan nameplate so they can supply you the correct information.

Click on "Contact a Sales Rep" on our website for the name and contact information for our local sales office in your area.

Centrifugal Fan

USER MANUAL

