

Installation, Safety, Operation & Maintenance Manual and Parts List for Models 33S, 50S, 75S, 100S, 150S, 200S and 300S Portable Dust Collectors

NOTICE:

Read this complete manual before attempting to assemble, install, operate, move, inspect or service this Dust Collector.

ATTENTION: Receiving Department

All Cincinnati Fan products are packaged to minimize any damage during shipment. The freight carrier is responsible for delivering all items in their original condition as received from Cincinnati Fan. The individual receiving this equipment is responsible for inspecting this unit for any obvious or concealed damage. If any damage is found, it should be noted on the bill of lading before the freight is accepted and the receiver must file a claim with the freight carrier.

LONG TERM STORAGE NOTICE

If this dust collector will NOT be installed and put into service within 30 days, refer to the "Long Term Storage Instructions" on page 2. Failure to follow all applicable long term storage instructions will void your warranty. This dust collector must be stored indoors in a clean, dry location.



Models
33S, 50S & 75S

Cans or Drums
are not included



Models
100S, 150S & 200S

Specifications

Model No.	Motor HP	Max. CFM ①	Max. SP ②	dBA @ 5 FT.	Standard Dust Bag			Blower Wheel Dia.	Inlet Hose Size	Inlet Nozzle Size	Max. Drum Dia. ④	Full Load Amps ⑤		Approx. Ship Wt.
					Fabric	Area (Sq. Ft.)	Micron ③					115 Volt 1 Phase	230 Volt 3 Phase	
33S	1/3	335	3"	76	Cotton Sateen	12.5	10	8"	3"x 60"	4"x 4"	20"	5.8	1.8	32
50S	1/2	450	7"	78				9 3/4"	4"x 60"	5"x 5"	20"	6.8	1.9	48
75S	3/4	580	7"	78				10 5/8"	4"x 60"	5"x 5"	20"	8.8	2.4	53
100S	1	700	4 1/2"	83	Knit Polyester	18.0	5	10 5/8"	5"x 60"	6"x 6"	24"	11.2	3.2	72
150S	1 1/2	875	6 1/2"	76				11"	6"x 60"	7"x 7"	24"	16.0	4.4	85
200S	2	1100	8 1/2"	85				12 1/4"	6"x 60"	7"x 7"	24"	20.0	5.6	97
300S	3	1300	10"	84	Select oversized bag from pages 5 and 6.			13"	6"x 60"	7"x 7"	24"	Not available	7.6	113

① Maximum CFM at 0" S.P. (clean drum, dust bag, with 5 feet of inlet hose and inlet nozzle).

② Maximum additional static pressure (SP) at which point there will be no air flow.

③ Minimum micron size at which standard dust bag will capture 99%.

④ See Section V. INSTALLATION, Section A on page 6.

⑤ Starting amps are approximately 6-7 times the full load amps. High voltage amps are 1/2 of low voltage amps. Amp loads shown are approximate and will vary with different motors and/or brands.

All dimensions above are nominal. For complete dimensions, see page 15.

CONTENTS

Dangers, Warnings and Cautions	Page 3
I. Description	Page 4
II. Unpacking	Page 4
III. General Safety Information	Page 4
IV. Assembly	
A. Models 33S, 50S and 75S	Page 4
B. Models 100S, 150S 200S and 300S	Page 4-5
C. Oversized Dust Bags	Page 5
“HB” Type Bags	Page 5-6
“DB” Type Bags	Page 6
V. Installation	Page 6
A. Proper Cans, Drums and Unit Location.....	Page 6
B. Exhaust Volumes Required for Different Applications	Page 7
C. Duct Work Recommendations	Page 8
D. Electrical	Page 8
VI. Operation	Page 8
VII. Maintenance	Page 9
A. Motor.....	Page 9
B. Blower Wheel and Steel Components	Page 9
C. Cleaning the Blower Wheel.....	Page 9
D. Replacing the Blower Wheel.....	Page 9-10
E. Replacing the Motor.....	Page 10
F. Emptying the Can or Drum.....	Page 10
G. Emptying the Dust Bag.....	Page 10
H. Cleaning the Dust Bag.....	Page 10-11
VIII. Troubleshooting	Page 11
IX. Exploded View Drawing & Parts List for Models 33S, 50S & 75S	Page 12
X. Exploded View Drawing & Parts List	
For Models 100S, 150S, 200S & 300S	Page 13
XI. Exploded View Drawing & Parts List for Oversized Dust Bags	Page 14
XII. Dimensions and Performance Curves	Page 15
XIII. Limited Warranty, Liability, Responsibility and Return Policy	Page 16

Long Term Storage Instructions

NOTE: Failure to adhere to these instructions voids all warranties in their entirety.

1. Storage Site Selection:

- a. Level, well drained, firm surface in clean, dry, location with a temperature range of 50°F (10°C) to 90°F (60°C).
- b. Isolated from possibility of physical damage from construction vehicles, erection equipment, etc.
- c. Accessible for periodic inspection and maintenance.

2. Carton should be supported under the entire bottom and open at the top allowing it to “breathe”

3. If dust collector will be stored for more than three (3) months, the entire unit must be **loosely** covered with plastic.

4. Storage Maintenance:

A periodic inspection and maintenance log, by date and action taken, must be developed and maintained for each unit. See example below. **Each item must be checked monthly.**

EXAMPLE:

Storage - Maintenance Schedule Log

ITEM	ACTION	DATE CHECKED
1	Re-inspect unit to insure any protective devices used are functioning properly. Check for scratches in the finish which will allow corrosion or rust to form.	
2	Rotate the blower wheel a minimum of ten (10) full revolutions to keep the motor bearing grease from separating and drying out. <i>This step is critical.</i>	

BE SURE TO READ ALL DANGER, WARNING AND CAUTION NOTICES BELOW BEFORE PROCEEDING WITH ANY INSTALLATION OR OPERATION OF THIS DUST COLLECTOR. MAKE SURE YOU ARE IN COMPLIANCE WITH ALL LOCAL, STATE, FEDERAL AND SAFETY GUIDELINES, REGULATIONS AND STANDARDS.

⚠ DANGER

The National Fire Protection Association (NFPA) has defined the following materials as “reactive metals”: **Aluminum, Magnesium, Tantalum, Titanium and Zirconium.**

Improper handling, machining, collection and disposal of these materials can result in a severe explosion and/or fire resulting in death, severe personal injury and extensive, immediate and surrounding property damage. Consult the NFPA for current standards. **Review of your application and future type of installation must be completed by your local Fire Marshal or an Authorized Fire Department Official prior to the installation of any equipment for this purpose.**

This Standard combines the following previous Standards into one Standard: NFPA 480, NFPA 481, NFPA 482, NFPA 485 and NFPA 651. NFPA 484 was approved as an American National Standard on July 19, 2002.

We have reviewed the latest NFPA Standard 484 for “Combustible Metals, Metal Powders, and Metal Dusts, 2002 Edition” and we have determined:

Cincinnati Fan Dust Collectors ARE NOT designed to collect any “reactive metal” material. They DO NOT meet NFPA Standard 484.

⚠ DANGER

According to the National Fire Protection Agency (NFPA), this dust collector **CANNOT** be used to collect any wood dust or chips AND metal dust or chips. It can be used for either type of material, **but not both.**

Hot metal dust or chips from grinders can start a fire or cause an explosion if mixed with wood dust or chips. **Also, this dust collector CANNOT be used with sanders or abrasive planners that have mechanical material feeds.** For clarification, see “NFPA standard 664, NFPA Standard for the Prevention of Fires and Explosions in Wood Processing and Woodworking Facilities 2007 Edition” for the proper design, installation, operation and maintenance of dust collectors and dust collection systems.

⚠ WARNING

There is a high speed blower wheel inside the blower housing and another one on top of the motor. Both can amputate fingers or grab loose clothing or neckties. Always wear safety glasses when operating this dust collector.

⚠ WARNING

Keep dust bag clean.

A clogged dust filter bag may prevent collection of harmful dust. **Read this manual for proper cleaning procedure. Replace worn or damaged dust bag immediately. NEVER operate this dust collector without a dust bag in place.**

⚠ WARNING

This dust collector is not designed to be used out doors where it will be subjected to the elements. Keep indoors or in a covered area not subject to rain or snow.

⚠ WARNING

This dust collector is not designed to collect fumes or powders less than 1 micron in size. This dust collector should **NEVER** be used to collect **ANY** liquids.

⚠ CAUTION

The motor has a cooling fan and fan cover on top of the motor. **DO NOT** place anything on top of the cooling fan cover at any time. Doing so will cause the motor to overheat and fail.

⚠ CAUTION

This dust collector, when fully assembled, will be top heavy. It can be overturned if bumped or not placed on a clean, flat, level surface.

⚠ CAUTION

DO NOT use this dust collector to collect **ANY** type of yard waste, i.e. leaves, paper, mulch, berries, etc.

⚠ DANGER



Hazardous voltage.
Can cause electrical shock and death.



High speed rotating equipment.
Can cause severe personal injury. Never operate this equipment without all required safety guards in place.



Lock out / Tag out.
To prevent any personal injury before performing any inspection or service.

⚠ DANGER



Read this entire manual.
This manual contains information you need to insure your safety and satisfactory operation of your dust collector.

⚠ WARNING

Plastic drums should not be used as they will not support the weight of the dust collector. **DO NOT** use any PVC pipe or hose in any part of the duct system.

I. DESCRIPTION

This dust collector is designed to help maintain clean, safe conditions around dust creating machines in workshops and factories. The flexible hose, included with each unit can be connected directly onto the dust creating machine.”

See page 7 for exhaust volumes required for different applications.

This dust collector is not designed to be used in a system that requires high static pressures. Avoid using any hose or duct less than 3” in diameter. It will require much higher static pressure and will restrict air flow.

DO NOT collect any material that could ignite any plastic or cloth parts of this dust collector.

II. UNPACKING

Carton must be in upright position before opening. Inspect for any shipping damage and advise freight carrier immediately if any damage is found. Check Parts List for any missing or damaged parts.

RETAIN THIS MANUAL FOR FUTURE REFERENCE.

III. GENERAL SAFETY INFORMATION

- A. Follow all local, state and federal safety codes including the National Electrical Code (**NEC**), the National Fire Protection Agency (**NFPA**) standards, the Occupational Safety and Health Act (**OSHA**) and the Environmental Protection Act (EPA).
- B. **All electrical wiring should be performed only by qualified personnel or a licensed electrician.**
- C. Make sure the power source conforms to the requirements of the dust collector motor.
- D. Exercise caution when the unit is in operation. There is a high speed blower wheel inside the blower housing and another one on the top of the motor. Both can amputate fingers or grab loose clothing or neckties. Always wear safety glasses when operating this dust collector.

All the assembly instructions on the following pages are based on standard units as catalogued. With all of the available accessories or options, we cannot include every combination.

IV. ASSEMBLY

A. MODELS 33S, 50S and 75S (Refer to Figure 1 on Page 12)

Assembly includes the installation of the air baffle, lid gasket, discharge elbow, dust bag, hose and nozzle.

1. To install the air baffle and lid gasket, gently place unit upside down on a cardboard covered flat area.
 - a. Attach the air baffle (**17**) as shown using the bolts included.
 - b. Remove the paper protection from the sticky side of the lid gasket (**18**). Install the gasket on the

underside of the drum lid/inlet guard assembly (**11**) so that the side of the gasket is against the lip of the lid.

2. Carefully turn over the assembly so the motor is on top and place it on top of a 30-35 gallon can or drum.

NOTE:

If you are installing the standard dust bag, (Models 33S, 50S and 75S) continue with Step 3 below.

If you are installing an oversized dust bag, (Available on Models 50S & 75S only) go to Section C on page 5.

3. a. The discharge elbow (**8**) has two 1/8” holes at one end of the elbow. Slide the end with the two holes over the discharge guard (**5**) on the blower housing. Line up the two holes in the elbow with the two holes in the guard. Install and tighten the 2 self tapping screws included in the plastic bag of hardware.
- b. Slide the dust bag clamp (**9**) over the inlet collar of the dust bag (**10**). Slide the dust bag collar over the end of the discharge elbow (**8**). The dust bag inlet collar should overlap the end of the bag elbow by about 2”. The clamp should be centered in between the two ends. Tighten the clamp with a screw driver or nut driver.
- c. **Model 33S ONLY.** (For models 50S & 75S, go to Step e)
Mount 4” to 3” sheet metal inlet reducer (**15**) onto inlet collar of drum lid (**11**). Tighten draw lug nut & screw.
- d. Slide hose clamp (**13**) over one end of hose (**14**) and slide hose over inlet reducer (**15**). Tighten clamp.
- e. **Model 50S & 75S:**
Slide hose clamp (**13**) over one end of hose (**14**) and slide hose over inlet collar of lid (**11**). Tighten clamp.
- f. **Models 33S, 50S and 75S.**
Slide hose clamp (**13**) over opposite end of hose (**14**) and slide hose onto inlet nozzle (**12**). Tighten clamp.

B. MODELS 100S, 150S, 200S and 300S (Refer to Figure 2 on Page 13)

Assembly includes the installation of the inlet deflector, intake cylinder, lid gasket, discharge bag elbow, dust bag, hose and nozzle.

1. To install the intake cylinder, deflector elbow and lid gasket, gently place the unit upside down on a cardboard covered flat area. **Two people should perform this function.**
 - a. To attach the inlet deflector (**16B**), remove the two 1/4-20 nuts and washers that hold the inlet elbow (**16A**) onto the drum lid (**11**). Install the inlet deflector (**16B**) over the same bolts that hold the inlet elbow (**16A**). Reinstall the 1/4-20 nuts and washers and tighten.

IV. ASSEMBLY (Continued)

NOTE

The intake cylinder/guard (#19) in Step 1b below, MUST be installed. Failure to install this part will GREATLY reduce the airflow (CFM) of the dust collector.

- b. Attach the intake cylinder (19) with the four 1/4-20 bolts and lock washers that were supplied in the hardware packet. The four bolts go through the four mounting lugs on the intake cylinder and are screwed into the 4 threaded inserts in the drum lid (11).
 - c. Remove the paper protection from the sticky side of the lid gasket (18). Install the gasket on the underside of the drum lid (11) so that the side of the gasket is against the lip of the lid.
2. Two people should turn over the assembly so the motor is on top and place it on top of a 55-gallon can or drum.
3. Attach inlet hose and nozzle.

Step 3 is for Model 100S ONLY. For Models 150S, 200S and 300S, go on to Step 4 below.

- a. Mount the 6" to 5" metal reducer (15) onto the inlet elbow (16A). Tighten the draw lug nut on the reducer.
 - b. Slide hose clamp (13) over one end of hose (14) and slide hose over inlet reducer (15). Tighten clamp.
4. Slide hose clamp (13) over opposite end of hose (14) and slide hose over inlet nozzle (12). Tighten clamp.

NOTE:

If you are installing the standard dust bag, (Models 100S, 150S and 200S) continue with Step 6 below.

If you are installing an oversized dust bag, (Available on Models 100S, 150S and 200S) go to Step C below.

All Model 300S units require an oversized dust bag. Go to Step C below.

6. a. The discharge elbow (8) has two 1/8" holes at one end of the elbow. Slide the end with the two holes over the discharge guard (5). Line up the two holes in the elbow with the two holes in the guard. Install, and tighten, the 2 self tapping screws included in the plastic bag of hardware.
- b. Slide the dust bag clamp (9) over the inlet collar of the dust bag (10). Slide the dust bag collar over the end of the bag elbow (8). The dust bag inlet collar should overlap the end of the bag elbow by about 2. The clamp should be centered in between the two ends and above the rib of the bag elbow. Tighten the clamp.

C. INSTALLING OVERSIZED DUST BAGS (Refer to Figures 3 or 4 on page 14).

Steps 1a through 1d are for all Models 50S, 75S, 100S, 150S, 200S and 300S.

1. a. The discharge bag elbow (8) is not used. The discharge bag elbow is never used on Model 300S.

- b. Slide a hose clamp (4 or 9) onto both ends of the dust bag connector hose (6 or 10).
- c. Slide one end of the hose over the guard (5) on the blower housing discharge. Tighten the hose clamp.
- d. Slide the hose connector (5 or 8) into the other end of the hose so that half of the connector length is inside the hose. Tighten the hose clamp around the hose and connector.

For "HB" Hanging Bags (Figure 3), proceed with Step 2. DO NOT use "HB" Bags on Models 50S & 75S.

For "DB" Drum Bags (Figure 4) proceed to Step 5 on Page 6.

2. "HB" type Hanging Bags are only recommended when there is not enough floor space for a second 55 gallon drum next to the dust collector. However, they are more cumbersome to empty and require emptying much more often. A "DB" type bag will be much easier to empty and will not require being emptied as often.
 - a. Assembly of the "J" hooks (2) onto the angle iron ring (1).

Thread a 1/4-20 nut all the way onto a "J" hook. Install a 1/4" flat washer. Put threaded end of the "J" hook nut and washer assembly through a hole in the angle iron ring. Install a second washer on top of the ring hole. Install a second 1/4-20 nut on top of the flat washer and tighten. Repeat these steps for each "J" hook.
3. a. Slide a hose clamp (4) over the inlet collar in the side of the HB dust bag (3).
 - b. Slide the inlet collar of the dust bag over the exposed end of the hose/bag connector (5) that you connected in Step C-1,d above.
 - c. Secure the dust bag collar to the hose connector with the hose clamp.
4. **This step will be performed much more safely with two people on separate ladders.**
 - a. Put one bag grommet over each "J" hook in the ring/hook assembly.
 - b. Carefully start climbing the ladders while holding onto the ring/bag/hose assembly.
 - c. Raise the ring/bag/hose assembly high enough above the ground without putting too much tension on the bag or the hose entering the side of the bag. Also make sure the hose (6) is not "kinked" at the discharge of the dust collector. **This is the proper height for the ring to hang off of the ground.**
 - d. Measure the distance from the ring to the ceiling joist, rafter or truss.
 - e. Securely hang the ring from a ceiling joist, rafter or truss with approved cable or chains.
 - f. **The bag should be hanging so it doesn't touch the floor AND it doesn't pull on the dust collector discharge hose. See Figure 3 on page 14.**

IV. ASSEMBLY (Continued)

NOTE:

Never let an HB type hanging bag collect over 12" of dust or chips in the bottom of the bag. When dust or chips reach a depth of 12", the bag must be emptied. If not, the weight of the material inside the bag may cause the bag to tear from the grommet straps at the top or at the zipper in the bottom.

See Dust Bag Cleaning Instructions on page 11.

For "DB" Drum Bags (Figure 4) proceed with Step 5.

5. The "**DB**" type Drum Mount dust bags come in three sizes. Approximate dimensions are:
 - DB24x40** is 24" diameter x 36" high for models 50S and 75S. Available in two fabric types.
 - DB24x80** is 24" diameter x 72" high for models 100S, 150S, 200S and 300S. Available in three fabric types.
 - DB48x80** is 48" diameter x 72" high for models 100S, 150S, 200S and 300S. Available in three fabric types.
- a. You should have completed Steps **C-1,a** through **C-1,d** on page 5.
- b. Slide a hose clamp (**9**) over the inlet collar in the side of the dust bag.
- c. Slide the inlet collar of the dust bag (**7**) over the exposed end of the hose connector (**8**) that you installed in Step **C-1,d** on page 5. Secure the dust bag collar to the hose connector by tightening the hose clamp.
- d. The "**DB**" type Drum Mount dust bag has an outer and an inner sleeve in the bottom opening of the bag. There is also a belt on the outside of the bag. Loosen the belt as far as possible.
- e. Roll back the outer sleeve and slide the inner sleeve **inside** an open top 55 gallon drum. Now,

unroll the outer sleeve down over the **outside** of the drum so that the bottom of the bag overlaps the top of the drum by 4-6". Tighten the belt as tight as possible

NOTE:

If you will be collecting dust smaller than 10 microns, we recommend you remove the belt from the bag and install a 55 gallon drum lid clamp around the top of the drum. This will provide a better seal between the drum and the dust bag.

- f. There is a single grommet in the top, center of the bag. Connect one end of a rope or cable through the eye of the grommet and connect the other end to a rafter or truss in the ceiling. This is only needed to hold the bag up when the dust collector is turned off. **Leave about 12" of slack in the rope or cable.**

V. INSTALLATION

A. Proper Cans, Drums and Unit Location

Models 33S, 50S and 75S should be mounted on top of a 25-30 gallon garbage can or a 30-35 gallon drum. The garbage can or drum should have a diameter no less than 18" and not more than 20". **Do not use plastic cans or drums.** A fiber can or drum may be used if it has a fire resistant foil liner and it can support the weight of the dust collector.

Models 100S, 150S, 200S and 300S should be mounted on top of a 55 gallon, roll-top, steel drum **only**. The drum should have a diameter no less than 22" and not more than 24". **Do not use plastic or fiber drums.** Place the assembled dust collector as near as possible to the dust generating source.

B. Exhaust Volumes Required for Different Applications (1)

WOODWORKING		
Equipment	Size	Min. CFM Required (2)
Jointer	Knife Length = Up to 6"	350
	6+" to 12"	440
	12+" to 20"	550
	over 20"	800
Sander, Belt (Horizontal)	Belt Width = Up to 6"	790 (3)
	6+" to 9"	900 (3)
	9+" to 14"	1240 (3)
Sander, Disc	Disc Diameter = Up to 12"	350
	12+" to 18"	450
	18+" to 26"	550
Sander, Drum	Drum Surface = Up to 200 (in square inches)	350
	201 to 400	550
	401 to 700	785
	701 to 1400	1100
Saw, Band	Blade Width = Up to 2"	700 (3)
	2+" to 3"	900 (3)
	3+" to 4"	1350 (3)
Saw, Radial	Hood behind blade =	430
	From port on blade guard =	70
	Total =	500
Saw, Swing	Blade Diameter = Up to 20"	350
	over 20"	440
Saw, Table	Blade Diameter = Up to 16"	350
	16+" to 24"	440
	over 24"	550
	Variety with dado =	550
Planer, Single	Knife Length = Up to 20"	785
	20+" to 26"	1100

METALWORKING		
Equipment	Size	Min. CFM Required (4)
Buffing, Belt	Belt Width = Up to 3"	220
	3+" to 5"	300
	5+" to 7"	390
	7+" to 9"	500
	9+" to 11"	610
Buffing, Wheel	11+" to 13"	740
	Wheel Width = 2" (5)	300
	3"	500
	4"	610
Grinding Wheel	5"	740
	6"	1040
	Wheel Width = 1" (5)	220
	1-1/2"	220
	2"	390
Grinding Wheel	3"	500
	4"	610
	5"	880
	6"	1200
	Grinding Wheel	Wheel speeds below 6500 sf/m
1-1/2"		390
2"		610
3"		740
4"		880
Grinding Wheel	Wheel speeds above 6500 sf/m	220
	1-1/2"	390
	2"	610
	3"	740
	4"	880
Grinding Wheel	5"	1200

Abbreviations used in charts:
 CFM = Cubic feet of air per minute
 FPM = Feet per minute
 sf/m = Surface feet per minute

- (1) The exhaust volume (CFM) requirements shown are "American Conference of Governmental Industrial Hygienists (ACGIH®), *Industrial Ventilation: A Manual of Recommended Practices*, 19th Edition. Copyright 1986. Reprinted with permission." Consult manual for more detailed recommendations. Contact them at www.acgih.org.
- (2) CFM's required are minimums per each equipment type. Duct velocity should not be less than 3500 FPM to prevent wood dust from settling in duct work.
- (3) Requires 2 nozzles or hoods. CFM's shown are total CFM for both nozzles or hoods.
- (4) For all metalworking applications, duct velocity should be at least 3500 FPM for light grinding or buffing and at least 4500 FPM for heavy grinding or buffing to prevent settling in duct work.
- (5) The wheel hood should cover at least 75% of the wheel to be considered a good enclosure.

How To Select The Proper Size Dust-Master Dust Collector

Although **Cincinnati Fan Dust-Master** dust collectors will give you excellent results in collecting wood chips, fine dust and metal shavings, they are not designed to work in large central system applications. These are portable units that can be moved from machine to machine. To select the proper size **Dust-Master**, use the criteria below:

- Add the "CFM REQUIRED" for each machine per the above chart. This is your TOTAL CFM REQUIRED.
- Now, select the **Dust-Master** model from page 1 with a "Max. CFM" greater than your TOTAL CFM REQUIRED in Step 1. If none of the models on page 1 have a Max. CFM **greater** than your TOTAL CFM required, you will need more than one unit.
- If the unit will be in a "fixed installation" all ductwork should be sheet metal duct instead of flexible hose. The pressure drop through flexible hose can be 2-3 times that of smooth wall pipe. **DO NOT use any PVC or plastic pipe. It can deliver a severe static electric shock caused by high velocity dust passing through it.**
- The **Dust-Master** should be located as close to the machine as possible and preferably no more than 10 feet away.
- Use as few elbows as possible in your ductwork. The loss through one, 90° elbow is equal to approximately 10 feet of straight, smooth wall pipe.
- If the dust collector will be used for more than one machine, install slide gate dampers in the duct at **each** machine to "close off" that section of duct when using another machine. This will allow the dust collector to pull from only one machine at a time and thus increase the dust collector performance.
- Typically**, a Model 150S will work with up to 20 total feet of duct, a model 200S will work with up to 30 total feet of duct work and a 300S will work with up to 75 total feet of duct. These values are based on having dampers at each machine connection (as in note 6 above) and all duct work is smooth wall, sheet metal.

Also see Section C on Page 8.

C. Duct Work Recommendations

The maximum CFM rating for each model dust collector should be greater than the minimum required CFM as listed in the **Exhaust Volumes Required for Different Applications** chart on page 7.

If you will be connecting the dust collector into a piping system for more than one machine, the dust collectors maximum CFM should be greater than the minimum CFM required for each machine in the system. If the piping system will have slide gate dampers at each machine, with only one machine operating at a time, then the dust collector can handle more machines as long as the CFM required does not exceed the maximum CFM of the dust collector. As a rule of thumb, one dust collector can handle multiple machines as follows:

Model 33S & 50S ..One machine only.

Model 75STwo machines if within 5 feet of each other.

Model 100STwo machines if within 10 feet of each other.

Model 150STwo machines if within 20 feet of each other.

Model 200SUp to 30 feet of 5" duct, and 3 machines.

Model 300SUp to 75 feet of 5" duct, and 3-4 machines.

NOTE:

The number of machines you can collect from will depend on the CFM required per machine.

General Recommendations for Ductwork Systems:

1. The National Fire Protection Agency (NFPA) will no longer permit a single dust collector to be used to collect **BOTH** wood dust or chips **AND** metal dust or chips because of the possibility of a fire and/or explosion.
2. **DO NOT use any PVC pipe or flexible hose for duct work.** This is no longer permitted by the National Fire Protection Agency (NFPA). Dust traveling through PVC pipe or hose can build up a static electric charge.
3. Limit the use of flexible hose in any duct work to as little as possible. The pressure drop (resistance) through flex hose can be 2-3 times greater than smooth wall sheet metal pipe.
4. If connecting a dust collector to more than one machine, you should install slide gate dampers at each machine so the dust collector is only pulling from one machine at a time.

5. Keep the number of duct elbows to a minimum. A 90° elbow has the same pressure drop (resistance) as 10 feet of straight pipe.
6. Estimate 2 CFM reduction in air flow for each foot of straight pipe and 20 CFM reduction for each 90° elbow.
7. Pneumatic conveying of wood dust requires a minimum air velocity of 3500 feet per minute (FPM) in the duct or hose. For metal dust, the velocity can be from 3500 FPM to 4500 FPM. Velocities less than these will allow the dust to settle in the duct work or hose. Therefore, the CFM must not be reduced below these velocities.
8. Connect the dust collector inlet hose to the connector port built into the dust producing machine. If there is no port on the machine, place the inlet hose and inlet nozzle as close as safely possible where it will collect the most dust.
9. **DO NOT** use any duct or hose smaller than 3".

D. Electrical

All electrical connections and wiring must be performed by qualified personnel or a licensed electrician. Models 33S, 50S, 75S and 100S, with single phase, TEFC motors are pre-wired at the factory with a cord, plug and switch to operate on a 115 Volt, 1 Phase, 60 Hertz power supply. These motors are also connected for the proper blower wheel rotation.

All other motors must be wired by the user for the operating voltage as stated on the motor nameplate and wiring diagram. **All wiring must be in accordance with Underwriters Laboratories (UL) and the National Electric Code (NEC).** After all wiring is properly completed, apply power to the motor for 1-2 seconds and then turn it off. As the motor slows down, observe the rotation of the motor cooling fan on top of the motor. The proper rotation for all dust collector motors is Clockwise (**CW**) when looking down on top of the motor. If the motor is turning Counter-Clockwise (**CCW**), lock out the power to the motor and then make the wiring changes per the motor wiring diagram either on the motor nameplate or inside the motor conduit box.

VI. OPERATION

The only operation steps that need to be monitored are emptying the can or drum and the dust bag. The can or drum should never be allowed to become over 1/3 full. The bag should never be more than 1/4 full.

VII. MAINTENANCE

DANGER

HIGH SPEED ROTATING EQUIPMENT CAN CAUSE SEVERE PERSONAL INJURY.

There is a high speed blower wheel inside the blower housing and another one inside the fan cover on top of the motor. Always disconnect or lock out power to the motor and let the wheel come to a complete stop **BEFORE** attempting any inspection, service, maintenance or moving of this dust collector.

A. Motor

The bearings in the motor are lubricated and sealed for life so they will not require any additional lubrication during the life of the motor. Keep the motor clean as excessive dirt may prevent proper cooling of the motor. Use no more than 40 PSI air to blow off excessive dirt.

B. Blower Wheel and Steel Components

The cast aluminum wheel and steel components are generally maintenance free during the life of the unit. It is possible that very fine, sticky dust particles can build up on the blades and back plate of the blower wheel. When the unit is lifted off of the can or drum for emptying of the can or drum, you should also inspect the blower wheel for any material buildup. Using a flashlight, look into the blower inlet underneath the lid. Any material that has built up on the wheel must be removed to prevent the wheel from an imbalance situation that could cause a premature motor bearing failure and/or dangerous wheel failure. For proper cleaning instructions, see the following section.

C. Cleaning the Blower Wheel

This operation is best performed with the dust collector sitting on top of the can or drum.

1. Lock out and disconnect power to the motor.
2. Disconnect the discharge bag elbow (8) from the blower housing discharge. On units with oversized dust bags, disconnect the flex hose from the blower discharge.
3. There are two pop rivets that connect the discharge guard (5) to the top section of the blower housing discharge (4). These pop rivets should be drilled out with a 3/16" drill bit.
4. Using a 7/16" socket and wrench, loosen and remove all the 1/4-20 nuts & bolts holding the two housing halves (4 and 7) together around the blower housing flange.
5. After removing all the nuts and bolts, use a screw driver or pry bar to **carefully** break the sealant in between the two housing halves.
6. After the sealant is loosened, lift the motor side housing (4) and motor assembly off of the inlet side housing (7).
7. Set the blower housing/wheel/motor assembly on a work bench resting on the side of the motor.
8. If possible, clean the blower wheel (6) with a wire brush while the wheel is still on the motor shaft. Use

DANGER

HAZARDOUS VOLTAGE CAN CAUSE ELECTRICAL SHOCK AND DEATH.

Always disconnect or lock out power to the motor and let the wheel come to a complete stop **BEFORE** attempting any inspection, service, maintenance or moving of this dust collector.

CAUTION

WEAR EYE PROTECTION.

Always wear eye protection when operating, servicing or cleaning this dust collector with a high pressure air hose.

an air hose to blow off the wheel when finished. If it is not possible to clean the wheel while on the motor shaft, see **Section D. Replacing The Blower Wheel** below.

9. If cleaning the blower wheel while on the motor shaft was successful, use a putty knife to clean the excess sealant caulk off of the flanges of both blower housing halves (4 and 7).
10. Apply a fresh bead of silicone sealant to the housing flange on the blower housing inlet side (7).
11. Carefully reset the blower housing motor side (4) on top of the blower housing inlet side (7) so that the outside of the flanges and the discharges line up.
12. Reverse Steps 5 through 1, at left, to complete reassembly.

D. Replacing the Blower Wheel

This operation is best performed with the dust collector sitting on top of the can or drum.

1. First complete **Steps 1 through 7** for **Step C. Cleaning the Blower Wheel**, at left.
2. Now, follow the following steps to replace the blower wheel.
3. Measure the distance from the front of the wheel hub to the end of the motor shaft. **Keep this dimension.**
4. There are two set screws in the blower wheel. Using a 5/32" Allen wrench, remove the two set screws from the wheel hub.
5. Using two pry bars, place the pry bars behind the back plate of the wheel so that the pry bars are located behind two opposite wheel blades. This will give you the most leverage. Pry the wheel off of the motor shaft being careful not to damage or distort the blower housing.
6. After removing the wheel, clean it thoroughly with a wire brush if you will be reusing it.
7. If the wheel is eroded, **DO NOT** reuse it. It will be out of balance and will damage the motor bearings.
8. If you can reuse the wheel, you **MUST** replace the set screws in the wheel hub. **Set screws can never**

be used more than once. Replace them with 5/16-18 set screws with a knurled head and a nylon locking patch on the side of the screw.

9. File any burrs on the motor shaft from the previous set screws and dress up the keyway in the motor shaft with a file.
10. Using a rubber or raw hide hammer, reinstall the present wheel or install a new wheel onto the motor shaft. Locate the wheel hub on the motor shaft to the same dimension you took in **Step 3** on page 9.
DO NOT use a steel hammer. It can damage the wheel and/or the motor bearings.
11. Line up the keyway in the motor shaft with the keyway in the wheel hub.
12. Install a new 3/16" square shaft key into the keyway. The key should be no longer than 1-1/2". The key should be positioned so it is flush with the end of the wheel hub.
13. Spin the wheel by hand to make sure it is not rubbing against the motor side of the blower housing.
14. Tighten the set screw over the shaft key first. Then tighten the set screw onto the motor shaft. Both screws should be tightened to 165 inch pounds.
15. Use a putty knife to clean the excess sealant caulk off of the flanges on both blower housing halves.
16. Apply a fresh bead of silicone sealant to the housing flange on the blower housing inlet side (7).
17. Carefully reset the blower housing motor side (4) on top of the blower housing inlet side (7) so that the outside of the flanges and the discharges line up.
18. Look into the discharge to make sure the blower wheel is not touching the inlet side of the blower housing.
19. Reverse **Steps 5 through 1**, on page 9 to complete reassembly.

E. Replacing the Motor

Before you attempt to replace the motor, make sure you have the correct replacement motor in your possession. All dust collector motors have the following characteristics:

- a. All Models 33S through 200S have a 56C frame with a C-Face mounting and a 5/8" shaft.
- b. Model 300S has a 145TC frame with a C-Face mounting and a 7/8" shaft.
- c. All motors used in the U.S.A. and Canada are 3450 RPM.
- d. All motors are Totally Enclosed (TEFC) or Explosion Proof (EXP). **NEVER** replace an EXP motor with a TEFC motor.
- e. The motor horsepower (HP) should match the HP of the motor you are replacing
- f. Make sure the new motor matches the operating voltage, phase and hertz of the old motor.

To replace the motor, follow **Steps 1 through 8**.

This operation is best performed with the dust collector sitting on top of the can or drum.

1. First complete **Steps 1 through 7** for **Cleaning the Blower Wheel**, on page 9.

2. Now, complete Steps 3 through 8 for **Replacing the Blower Wheel**, on page 9-10.
3. Before removing the motor, notice the location of the motor conduit box with relation to the blower housing.
4. With a 9/16" socket wrench, remove the four 3/8-16UNC bolts that hold the motor onto the motor side blower housing (4).
5. Remove the old motor.
6. Install the new motor onto the blower housing with the conduit box in the same orientation as noticed in **Step 3** above.
7. Replace or reinstall the four motor bolts and lock washers through the blower housing and into the four holes in the motor C-Face. Thread all bolts by hand and then tighten them with the socket wrench.
8. Follow **Steps 10 through 19** for **Replacing the Blower Wheel**, at left, to complete the reassembly of the dust collector.

F. Emptying the Can or Drum

NEVER ATTEMPT TO EMPTY A CAN OR DRUM WHILE THE UNIT IS OPERATING.

Empty the dust collector can or drum when it becomes 1/3 full. If the can or drum becomes too full, it will reduce the suction of the dust collector.

G. Emptying the Dust Bag

NEVER ATTEMPT TO EMPTY A DUST BAG WHILE THE UNIT IS OPERATING.

If you are collecting heavier chips, they will settle in the can or drum. Finer, lighter dust will go on into the dust bag. Therefore, the dust bag must also be emptied. The National Fire Protection Association (NFPA) states in their Standard 664, that wood dust in dust bags **MUST** be emptied "**every day or less if warranted.**" They should then be checked for holes, rips or loose seams that could leak. Emptying of the dust bag should only be performed by trained personnel wearing the proper clothing and the proper respiration equipment. How often you should empty the dust bag is really a judgment call. It will vary with the weight of the material you are collecting. No matter what you are collecting, **NEVER** let the bag get more than 1/4 full. **The major cause of having to replace dust bags is due to ripping because of too much weight in the bottom of the bag.**

H. Cleaning the Dust Bag

NEVER ATTEMPT TO OPERATE A DUST COLLECTOR WITHOUT THE DUST BAG IN PLACE.

WARNING:

If dust collector has been used to collect **ANY** materials included in the following list, it should **NOT** be cleaned. The dust bag must be disposed of using approved methods and procedures as adopted by the proper regulatory agency or agencies.

- A.** Any carcinogenic or biological materials.
- B.** Any flammable materials.
- C.** Any explosive materials.
- D.** Any water reactive materials.
- E.** Any nuclear materials.

- F. Any materials with cleaning instructions that are in contradiction with the following cleaning instructions.
- G. Any materials considered to be unsafe if they come in contact with the body.

4. Shake bag well to dislodge any material sticking to the pores of the bag.
5. Lay bag flat on table or floor.
6. Vacuum bag on both sides.
7. Put bag in washer.
8. Set washer for Gentle cycle.
9. Set water temperatures to **COLD** for wash and rinse cycles.
10. Add 1/4 cup of Woolite® detergent.
11. After washing is completed, hang bag on line to dry. **DO NOT** put in dryer.
12. After bag has dried, turn it right side in.
13. Do not use dust bag until it has thoroughly dried.

Cleaning Instructions

Acrylic Coated Polyester Felt, Teflon® Coated Polyester Felt or Nomex® Felt Dust Bags:

Because of the special coatings that have been applied to these materials, we do not recommend that these bag types be cleaned. They should be replaced when necessary or at least annually.

Cotton Sateen & Knit Polyester Dust Bags:

1. Inspect dust bag for holes. If any holes are found the bag must be replaced.
2. Unzip any zipper in the bag.
3. Turn bag inside out.

NOTICE: Overwashing, harsh detergents and/or drying too fast will cause bag to shrink and the inlet collar might become too small to fit back onto the unit. Shrinkage is a non-warranty claim. Dust bags can typically only be washed one time.

VIII. Troubleshooting Chart

SYMPTOM	POSSIBLE CAUSE(S)	CORRECTIVE ACTION
Unit will not operate.	<ol style="list-style-type: none"> 1. Improper electrical connection. 2. Defective fuse or circuit breaker. 3. Loose wiring connections. 4. Power turned off elsewhere. 5. Defective motor. 	<ol style="list-style-type: none"> 1. Turn OFF and lock out power to the motor. Check wiring to make sure it conforms to wiring diagram for the motor for the operating voltage. 2. Check and replace any defective or blown fuse or circuit breaker. DO NOT oversize for the circuit. 3. Check for loose wiring connections. 4. Check for other power control locations. 5. Have motor checked at authorized motor repair shop.
Motor overheating.	<ol style="list-style-type: none"> 1. Voltage supplied to motor too high or too low. 2. Improper electrical connection. 3. Dust bag and/or hose not in place. 	<p>NOTE: A normal motor will operate at 174° F.</p> <ol style="list-style-type: none"> 1. Turn OFF and lock out power to the motor. Check actual incoming voltage to motor. 2. Turn OFF and lock out power to the motor. Check wiring to make sure it conforms to wiring diagram for the motor for the operating voltage. 3. Must have dust bag and 5 foot hose minimum.
Excessive noise.	<ol style="list-style-type: none"> 1. Wheel rubbing inside of housing. 2. Worn or eroded blower wheel. 3. Accumulation of material on wheel. 4. Worn motor bearings. 	<ol style="list-style-type: none"> 1. Turn OFF and lock out power to the motor. Check wheel location inside housing. If rubbing, see Section VII-D on pages 9 and 10. 2. Turn OFF and lock out power to the motor. Check wheel. Clean or replace if necessary. 3. Turn OFF and lock out power to the motor. Check wheel. Clean or replace if necessary. 4. Replace motor. See Section VII-E on page 10.
Low suction.	<ol style="list-style-type: none"> 1. Incorrect blower rotation. 2. Suction hose too long. 3. Dust bag dirty 	<ol style="list-style-type: none"> 1. MOST COMMON CAUSE Turn unit OFF and observe the rotation of the motor cooling fan on top of the motor. It must be turning Clockwise (CW). If it is turning Counter Clockwise (CCW), reconnect the motor wiring leads for CW rotation. See motor wiring diagram. 2. Place unit closer to dust source and shorten hose. 3. DO NOT remove dust bag while unit is operating. Turn OFF power to the motor. Remove dust bag and clean or replace it per the instruction in Section H on pages 10 and 11.

IX. Exploded View Drawing Parts List for Models 33S, 50S and 75S

Fig. 1

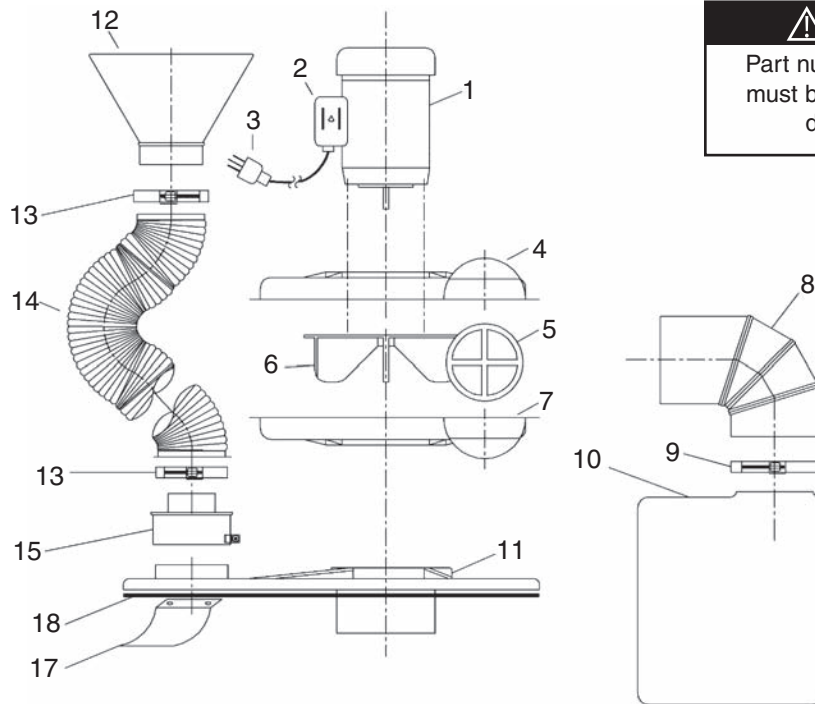

⚠ WARNING
Part numbers 5, 8, 9 and 10 must be in place at all times during operation.

Standard Replacement Parts List for Models 33S, 50S and 75S

Ref. No.	Qty./unit	Description	Part Number for Model		
			33S	50S	75S
1	1	Motor, 1 Phase, 115/230 Volt, 60 Hz., 56C, TEFC	37753 (1)	37754 (1)	372193 (1)
		Motor, 3 Phase, 230/460 Volt, 60 Hz., 56C, TEFC	371126	37154	37207
		Motor, 1 Phase, 115/230 Volt, 60 Hz., 56C, EXP	N/A	37152	372009
		Motor, 3 Phase, 230/460 Volt, 60 Hz., 56C, EXP	N/A	371679	372169
2	1	Switch, 115 Volt, TEFC only	■	■	■
3	1	Cord & Plug, 115 Volt, 60 Hz. only	■	■	■
4, 5 & 7	1	Blower Housing & Guard Assy. See note 2 at right	34025DC	34025DC	34025DC
5	1	Discharge Guard (only)	29330	29330	29330
6	1	Blower Wheel	5500102	5500402	5530602
8	1	Discharge Elbow	51269	51269	51269
9	1	Dust Bag Clamp	31379	31379	31379
10	1	Dust Bag	25035	25035	25035
11	1	Drum Lid & Inlet Guard Assy.	12062	12062	12062
12	1	Inlet Nozzle, Square	51014	51015	51015
13	2	Nozzle & Hose Clamp	31013	31379	31379
14	1	Hose, Inlet, 60" long	31623PP	31624PP	31624PP
15	1	Inlet Reducer	51048	—	—
16	1	Does not apply to these models	—	—	—
17	1	Air Baffle	51078	51078	51078
18	1	Lid Gasket	▲	▲	▲

NOTES

(1) Includes 8 foot cord, switch and 3 prong grounded plug for use on 115Volt, 1 Phase, 60 Hertz power supply only.

(2) Price includes both sides of stamped steel blower housing with an ABS discharge guard. This is only sold as an assembly for liability reasons. Only the discharge guard (5) can be purchased separately.

■ Must be purchased from the local motor manufacturers repair shop for the motor brand on your unit.

▲ Standard hardware store item. Purchase locally.

X. Exploded View Drawing Parts List for Models 100S, 150S, 200S and 300S

Fig. 2

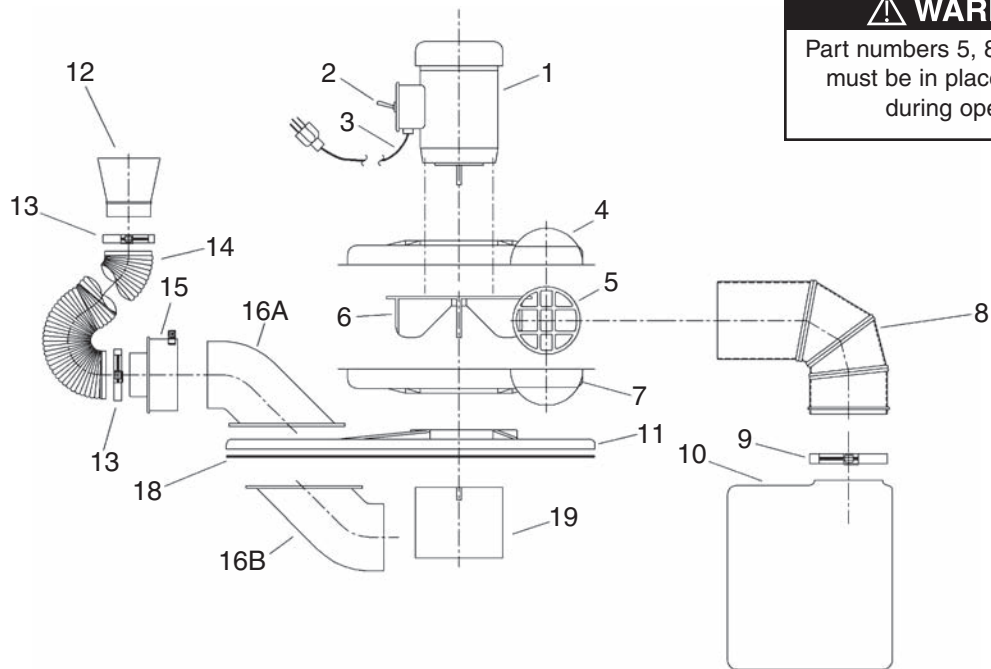

▲ WARNING
Part numbers 5, 8, 9, 10 and 19 must be in place at all times during operation.

Standard Replacement Parts List for Models 100S, 150S, 200S and 300S

Ref. No.	Qty. Unit	Description	Part Number for Model			
			100S	150S	200S	300S (1)
1	1	Motor, 1 Phase, 115/230 Volt, 60 Hz., 56C, TEFC	37755 (2)	373175	373677	N/A
		Motor, 3 Phase, 230/460 Volt, 60 Hz., 56C, TEFC	37254	37304	37353	374155 (3)
		Motor, 1 Phase, 115/230 Volt, 60 Hz., 56C, EXP	37252	373118	N/A	N/A
		Motor, 3 Phase, 230/460 Volt, 60 Hz., 56C, EXP	3725462	37305	37354	N/A
2	1	Switch, 115 Volt, TEFC only	■	—	—	—
3	1	Cord & Plug, 115 Volt, 60 Hz. only	■	—	—	—
4,5 & 7	1	Blower Housing & Guard Assy. (See note 4 at right)	34029DC	34029DC	34029DC	34029DC
5	1	Discharge Guard (only)	29318	29318	29318	29318
6	1	Blower Wheel	5530602	5500702	5501002	5510304
8	1	Discharge Elbow	51228	51228	51228	—
9	1	Dust Bag Clamp	31244	31244	31244	See page 14
10	1	Dust Bag	25071	25071	25071	
11	1	Drum Lid	12060	12060	12060	12060
12	1	Inlet Nozzle, Square	51016	51017	51017	51017
13	2	Nozzle & Hose Clamp	31016	31244	31244	31244
14	1	Hose, Inlet, 60" long	31625PP	31626PP	31626PP	31626PP
15	1	Inlet Reducer	51110	—	—	—
16A	1	Inlet Elbow	12061	12061	12061	12061
16B	1	Inlet Deflector				
17	1	Does not apply to these models	—	—	—	—
18	1	Lid Gasket	▲	▲	▲	▲
19	1	Intake Cylinder/Guard	51074G	51074G	51074G	51074G

NOTES

- (1) Model 300S always requires an oversized dust bag. See page 14 for the oversized bags and bag connector parts.
- (2) Includes 8 foot cord, switch and 3 prong grounded plug for use on 115Volt, 1 Phase, 60 Hertz power supply only.
- (3) This motor is a 145TC frame All other motors are 56C frame.
- (4) Price includes both sides of stamped steel blower housing with an ABS discharge guard. This is only sold as a complete assembly for liability reasons. Only the discharge guard (5) can be purchased separately.
- Must be purchased from the local motor manufacturers repair shop for the motor brand on your unit.
- ▲ Standard hardware store item. Purchase locally.

XI. Typical Oversized Dust Bag Connection Diagrams for Model 300S

OPTIONAL FOR MODELS 50S, 75S, 100S, 150S, & 200S

NOTE: DUST BAG FOR MODEL 300S MUST BE ORDERED WITH THE DUST COLLECTOR

Fig. 3 "HB" Type Dust Bags

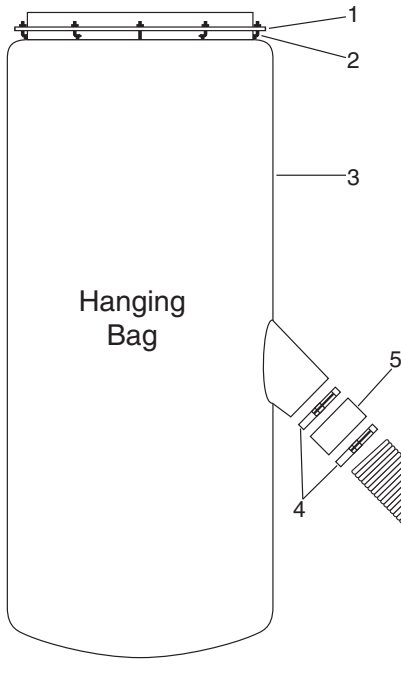

Parts List for #HB-24X80 and #HB-48X80 Hanging Bags

Ref. No.	Qty.	Description	For Dust Collector 100S to 300S Bag Type	
			#HB-24X80	#HB-48X80
1	1	Ring, 24" Dia., 6 holes	27131	—
	1	Ring, 48" Dia., 12 holes	—	27123
2	6	J Hooks with 1/4-20 nuts	▲	—
	12	J Hooks with 1/4-20 nuts	—	▲
3	1	Dust Bag, HB Type	Select material type from catalog	
4	3	Hose Clamps, 6"	31244	31244
5	1	Hose Connector, 6"	51088	51088
6	1	Hose, 6" dia. x 60" long	31626PP	31626PP

▲ Standard hardware store items available locally.

Ref. Numbers 4, 5 & 6 (for 6" hose) come as standard parts with all Model 300S.

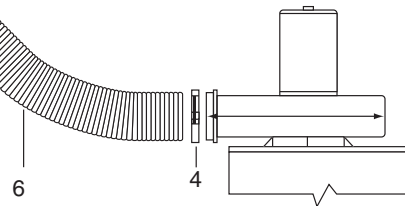
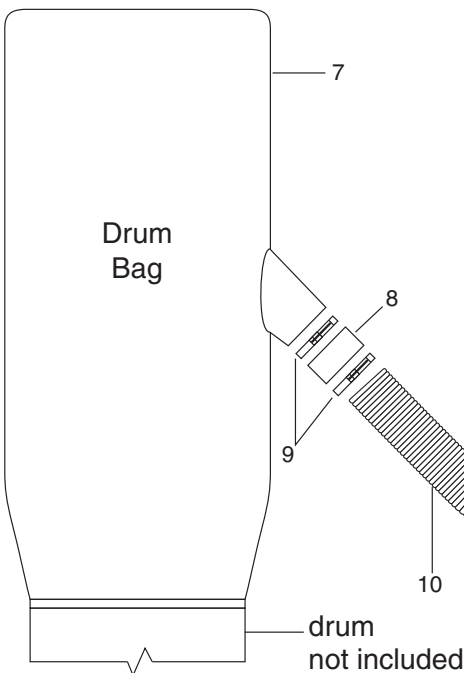

Fig. 4 "DB" Type Dust Bags



Parts List for #DB-24X40, #DB-24X80 and #DB-48X80 Drum Bags

Ref. No.	Qty.	Description	For Dust Collector		
			50S & 75S	#100S to 300S	
			Bag Type		
			#DB-24X40	#DB-24X80	#DB-48X80
7	1	Dust Bag, DB Type	Select material type from catalog.		
8	1	Hose Connector, 4"	51086	—	—
	1	Hose Connector, 6"	—	51088	51088
9	3	Hose Clamps, 4"	31379	—	—
	3	Hose Clamps, 6"	—	31244	31244
10	1	Hose, 4" dia. x 60" long	31623PP	—	—
	1	Hose, 6" dia. x 60" long	—	31626PP	31626PP

Ref. Numbers 8, 9 and 10 (for 6" hose) come as standard parts with all Model 300S.

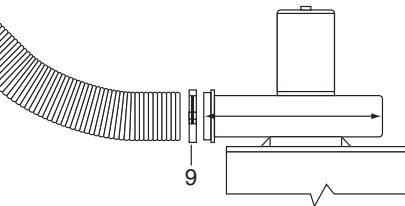

XIII. Dimensions and Performance Curves

NOTE: All dimensions are approximate for reference only. Dimensions subject to change without notice.

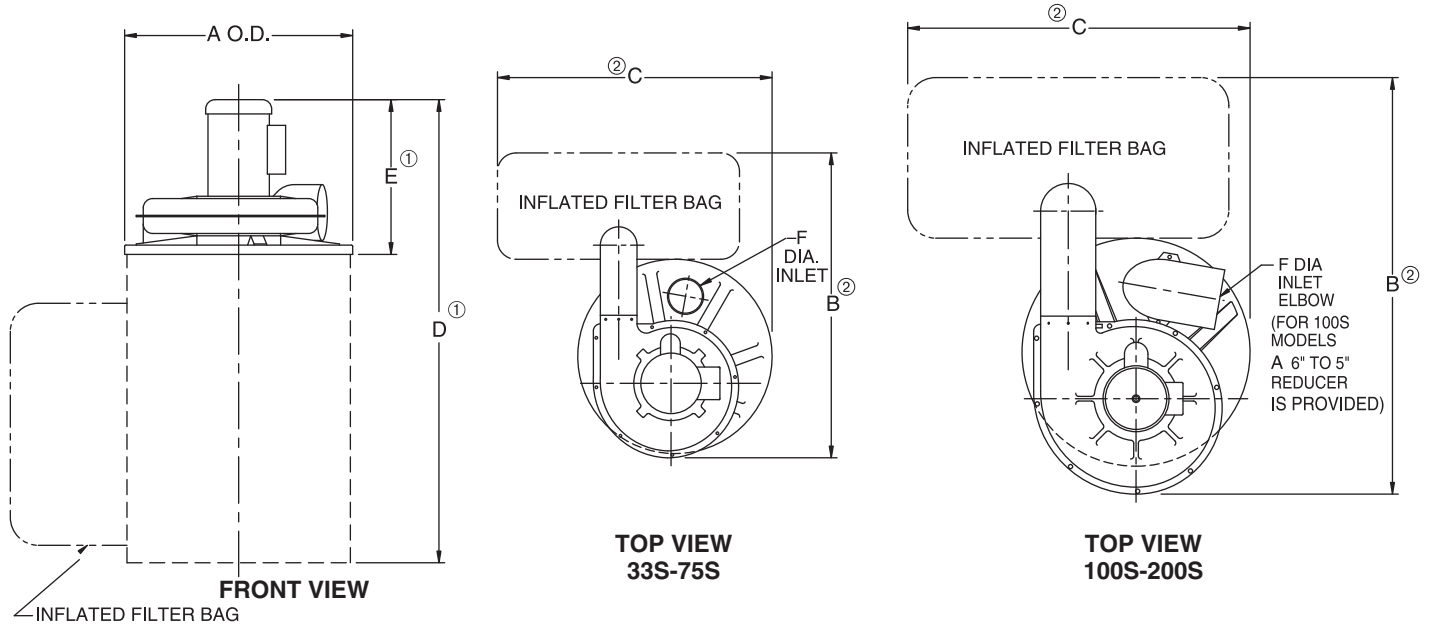

MODEL	A	B ^②	C ^②	D ^①	E ^①	F
33S - 75S	20 ⁷ / ₈	32 ³ / ₄	29 ¹ / ₂	40 ¹ / ₄	15	4
100S - 200S	24 ¹ / ₂	44 ³ / ₄	37	52 ³ / ₄	18 ³ / ₄	6

Model 300S dimensions are very similar to 200S dimensions except dust bag.

- ① Max. normal dimensions shown, varies with motor.
- ② Approximate dimensions with standard inflated dust bag.

Dust-Master Performance Curves

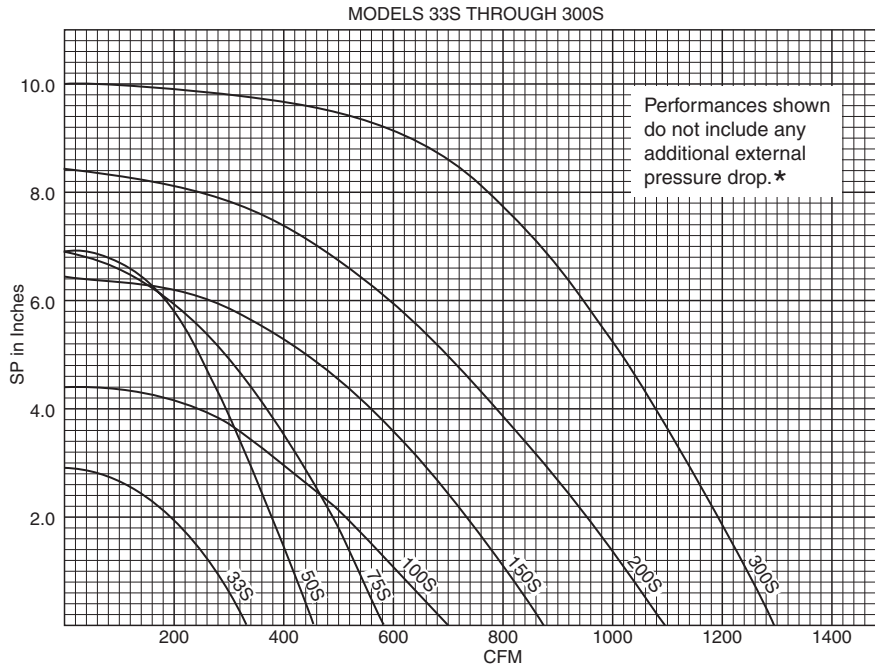

* Models 33S to 200S were tested with standard bags per page 6.

Model 300S was tested with a DB-48 x 80 bag.

All models with 5 feet of hose and nozzle.

XII. LIMITED WARRANTY:

Cincinnati Fan & Ventilator Company (Seller) warrants products of its own manufacture, against defects of material and workmanship under normal use and service for a period of eighteen (18) months from date of shipment or twelve (12) months from date of installation, whichever occurs first. This warranty does not apply to any of Seller's products or any part thereof which has been subject to extraordinary wear and tear, improper installation, accident, abuse, misuse, overloading, negligence or alteration. This warranty does not cover systems or materials not of Seller's manufacture. On products furnished by Seller, but manufactured by others, such as motors, Seller extends the same warranty as Seller received from the manufacturer thereof. Expenses incurred by Purchaser's in repairing or replacing any defective product will not be allowed except where authorized in writing and signed by an officer of the Seller.

The obligation of the Seller under this warranty shall be limited to repairing or replacing F.O.B. the Seller's plant, or allowing credit at Seller's option. **THIS WARRANTY IS EXPRESSLY IN LIEU OF ALL OTHER WARRANTIES EITHER EXPRESSED OR IMPLIED INCLUDING THE WARRANTIES OF MERCHANTABILITY AND FITNESS FOR A PARTICULAR PURPOSE AND OF ALL OTHER OBLIGATIONS AND LIABILITIES OF THE SELLER. THE PURCHASER ACKNOWLEDGES THAT NO OTHER REPRESENTATIONS WERE MADE TO PURCHASER OR RELIED UPON BY PURCHASER WITH RESPECT TO THE QUALITY OR FUNCTION OF THE PRODUCTS HEREIN SOLD.**

Removal of the Seller's nameplate or any generic fan nameplate containing the fan serial number voids all warranties, either written or implied. Failure to complete and document all the pre-startup and post startup checks and perform the suggested routine maintenance checks voids all warranties, either written or implied.

LIMITATION OF LIABILITY:

Notice of any claim, including a claim for defect in material or workmanship, must be given to Seller in writing within 30 days after receipt of the equipment or other products. Seller reserves the right to inspect any alleged defect at Purchaser's facility before any claim can be allowed and before adjustment, credit, allowance replacement or return will be authorized. See **RETURNS** below. Seller's liability with respect to such defects will be limited to the replacement, free of charge, of parts returned at Purchaser's expense F.O.B. Seller's plant and found to be defective by the Seller.

IN NO EVENT WILL SELLER BE LIABLE FOR SPECIAL, INDIRECT, INCIDENTAL OR CONSEQUENTIAL DAMAGES, WHETHER IN CONTRACT, TORT, NEGLIGENCE, STRICT LIABILITY OR OTHERWISE, INCLUDING WITHOUT LIMITATION DAMAGES FOR INJURY TO PERSONS OR PROPERTY, LOST PROFITS OR REVENUE, LOST SALES OR LOSS OF USE OF ANY PRODUCT SOLD HEREUNDER. PURCHASER'S SOLE AND EXCLUSIVE REMEDY AGAINST SELLER WILL BE THE REPLACEMENT OF DEFECTIVE PARTS AS PROVIDED HEREIN OR REFUND OF THE PURCHASE PRICE FOR DEFECTIVE PRODUCTS, AT SELLER'S SOLE OPTION. SELLER'S LIABILITY ON ANY CLAIM, WHETHER IN CONTRACT, TORT, NEGLIGENCE, STRICT LIABILITY OR OTHERWISE, FOR ANY LOSS OR DAMAGE ARISING OUT OF OR IN CONNECTION WITH PURCHASER'S ORDER OR THE PRODUCTS OR EQUIPMENT PURCHASED HEREUNDER, SHALL IN NO CASE EXCEED THE PURCHASE PRICE OF THE EQUIPMENT GIVING RISE TO THE CLAIM.

RESPONSIBILITY:

It is the understanding of the Seller that Purchaser and/or User will use this equipment in conjunction with additional equipment or accessories to comply with all Federal, State and local regulations. The Seller assumes no responsibility for the Purchaser's and/or User's compliance with any Federal, State and local regulations.

RETURNS:

Cincinnati Fan & Ventilator Company assumes no responsibility for any material returned to our plant without our permission. An **RMA** (Return Material Authorization) number must be obtained and clearly shown on the outside of the carton or crate and on a packing slip. Any items returned must be shipped freight prepaid. Failure to comply will result in refusal of the shipment at our receiving department.

DISCLAIMER

This manual, and all its content herein, is based on all applicable known material at the time this manual was created. **Any parts of this manual are subject to change at any time and without notice.**

If any statements, diagrams and/or instructions contained herein, **for components not manufactured by the Seller**, conflict with instructions in the manufacturer's manual (i.e.: motors), the instructions in the manufacturer's manual, for that component take precedent.

Should you want the latest version of this manual, please contact us or our sales office for your area. Or, you can print a current version by going to our website at: **www.cincinnati-fan.com**



**7697 Snider Road
Mason, OH 45040-9135**

www.cincinnati-fan.com for more information