

SPECIFICATIONS, ASSEMBLY INSTRUCTIONS, OPERATING INSTRUCTIONS & PARTS LIST







CENTRAL SYSTEM DUST COLLECTOR

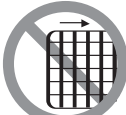

**READ ALL SAFETY INSTRUCTIONS
 AND WARNINGS ON PAGE 2
 BEFORE PROCEEDING**

Table of Contents	Page
Dust collector specifications	2
Standard dust bag filtration data	2
Dimensions	2
Introduction	2
Safety instructions and warnings	3
Unpacking, tools required for assembly & parts list	4
Parts photo for parts list on page 4	5
Assembly instructions	Pages 6 through 11
Connecting motor to power source	12
Maintenance	12
Replacement parts list	13
Replacement parts illustration for parts on page 13	14
Troubleshooting guide	15
Performance curves, limited warranty and returns	16

⚠ DANGER

	<p>Hazardous voltage. Can cause electrical shock and death.</p>		<p>High speed rotating equipment. Can cause severe personal injury. Never operate this equipment without all required safety guards in place.</p>		<p>Avoid injury. Never operate this equipment without all safety guards in place.</p>		<p>Lock out/tag out To prevent any personal injury before performing any inspection or service.</p>		<p>To avoid injury, you MUST read and understand all the instruction in the operating manual before inspecting or servicing this equipment.</p>		<p>Tip over hazard can cause injury or death. Do not move this equipment without mechanical assistance. Do not operate this equipment unless it is securely fastened to the floor.</p>
---	--	---	--	---	--	--	--	---	--	---	---

Dust Collector Specifications

MODEL NO.	MAX. CFM ①	MAX. S.P. ②	NOM. INLET O.D.	dBA @ 10 FT.	NOM. WHEEL O.D x W.	STANDARD MOTOR SPECS							Approx. Ship Weight
						HP	RPM	VOLTS	PH / HZ.	FRAME SIZE ③	F.L. AMPS ④		
											Low V.	High V.	
300CS/T1	1800	9.0	8"	78	13"x 3 1/4"	3	3450	230 only	1/60	145T	—	13.0	370
300CS/T3	1800	9.0	8"	78	13"x 3 1/4"	3	3450	230/460	3/60	145TC	7.6	3.8	360
500CS/T1	2100	11.0	8"	84	14"x 6"	5	3450	230 only	1/60	184T	—	19.8	425
500CS/T3	2100	11.0	8"	84	14"x 6"	5	3450	230/460	3/60	184TC	12.0	6.0	380
750S/T3	2400	14.8	8"	85	15 3/4"x 6"	7 1/2	3450	230/460	3/60	184TC	18.4	9.2	460

① Maximum CFM with clean drums, bag and no additional ductwork.

② Maximum additional static pressure at which point there will be no air flow. Also see performance curves on page 16.

③ Frame size can vary depending on motor and/or vendor.

④ Starting amps are approximately 6-7 times the full load amps shown. Check motor nameplate for actual full load amps.

Standard Dust Bag Filtration Data

MODEL NO.	STANDARD BAG MATERIAL ⑤	APPROX. BAG AREA (in Sq. Ft.)	EFFICIENCY @ MICRON SIZE
300CS/T1	Knit Polyester	50	99% of 5 Micron or larger
300CS/T3			
500CS/T1			
500CS/T3			
750CS/T3	Acrylic Coated Polyester Felt	100	99% of 1 Micron or larger

⑤ Maximum temperature limit for all standard dust bags is 275° F. (135° C.)

Reference Dimensions

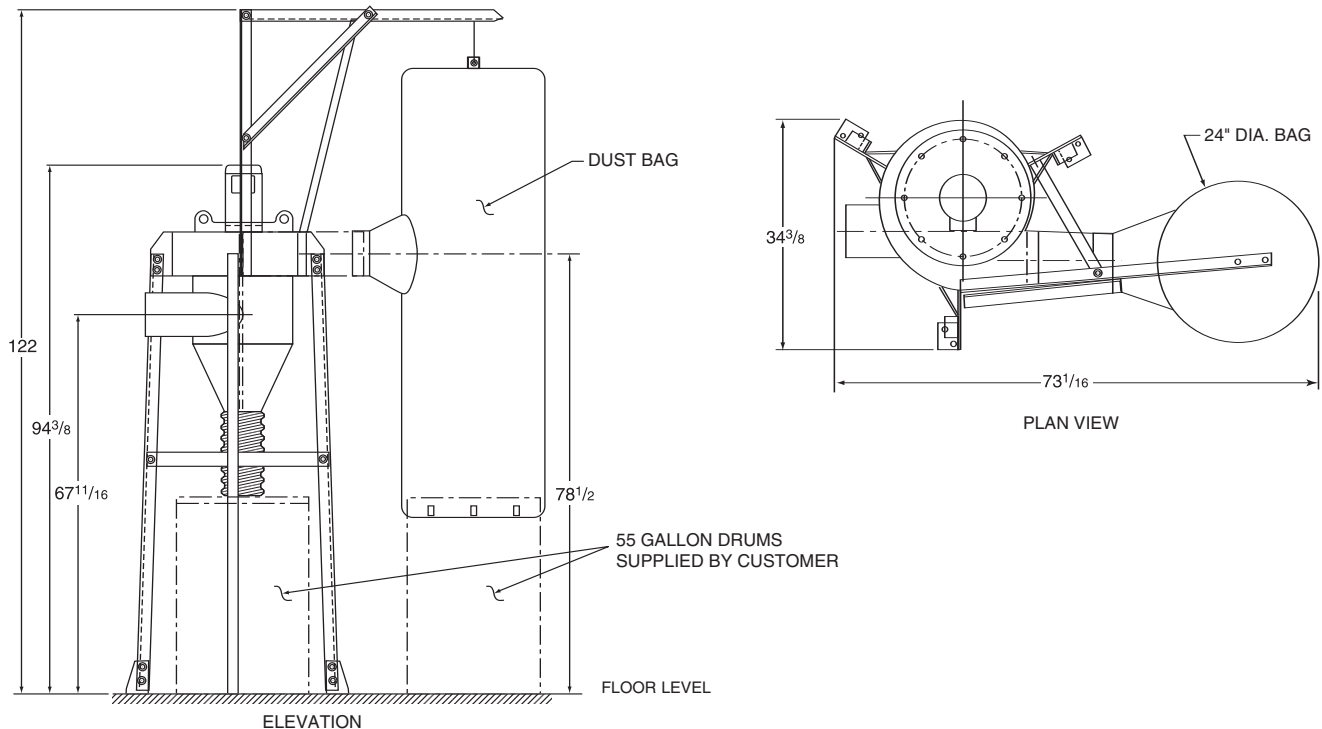

Introduction

These dust collectors are designed to help you maintain a clean and safe work area around machines that create dust in workshops or factories. Dust collectors collect dust by moving large volumes of air at low suction pressures. Vacuum cleaners and "shop vacs" are designed to move low volumes of air at very high suction pressures. For these reasons, dust collectors should not be used to sweep floors like vacuum cleaners or shop vacs. Dust collectors should be used to capture the dust coming off a machine before it ends up on the floor or floating in the air. Because of the complexities involved in designing a dust collector system for each individual installation, we recommend that you refer to the "Air Handling Systems" brochure enclosed with this manual. The "Air Handling Systems" brochure includes technical system sizing information and component parts for correct system installation. Also, see performance curves on page 16.

Their phone & fax numbers are on the web at: www.airhand.com or you can E-mail them at: sales@airhand.com

WARNING!

READ ALL SAFETY RULES AND WARNINGS BELOW *BEFORE* PROCEEDING WITH ANY ASSEMBLY, OPERATION, INSPECTION OR MAINTENANCE OF ANY PART OF THIS DUST COLLECTOR SYSTEM.

WARNING!

The National Fire Protection Agency (NFPA) Standard 484 requires specific dust collector and duct work design, configuration and maintenance when collecting any potentially reactive metal dust. The National Fire Protection Agency (NFPA) has defined the following materials as “reactive metals”;
Aluminum, Magnesium, Tantalum, Titanium and Zirconium
The dust collectors in this manual ARE NOT designed to meet NFPA Standard 484 and therefore, ARE NOT APPROVED for use in the collection of any reactive metal dust.

SAFETY RULES

It is your responsibility to follow *all* local electrical and safety codes including the National Electric Code (NEC), the Occupational Safety and Health Act (OSHA) and the Environmental Protection Agency (EPA).

1. You are responsible for installing, operating and any maintenance of this dust collector in accordance with all local and national electrical codes as specified by the National Electric Code (NEC).
2. All electrical connections and wiring of this dust collector should be performed by a qualified licensed electrician in accordance with all electrical codes. This dust collector must be grounded in accordance with National Electric Code (NEC) requirements.
3. Replacement of any damaged or worn power cables must be done immediately by a qualified licensed electrician.
4. The power cable must be protected and not allowed to come into contact with any sharp objects, grease, oil, hot surfaces or chemicals. Never allow the power cable to become kinked or knotted.
5. Make sure that the power source to the dust collector motor conforms to the motor requirements.
6. **Disconnect or lock out the dust collector motor from the power source and let the motor come to a complete stop BEFORE attempting ANY type of cleaning, inspection, servicing or moving of this unit including removing the dust bag.**
7. **DO NOT OPERATE THIS UNIT WITHOUT THE DISCHARGE GUARD AND DUST BAG IN POSITION.**
8. Always wear safety glasses when working around or performing inspection or maintenance on machinery.
9. Only metal drums should be used below the cyclone and the dust bag if you are collecting metal grinding dust. Fiber drums or plastic drums should only be used for collecting wood chips or saw dust.
10. Keep away from unit while it is operating.
 - a. There is a very high speed blower wheel inside of the blower housing that can amputate fingers and grab loose clothing or neckties.
 - b. There is also a very high speed cooling fan on the top of the motor that must be avoided for the same reasons as mentioned in item (a.) above.
11. This unit is heavier than the legs it sits on and can be overturned if not placed on a clean, flat, level surface. The holes provided in each foot should be used to anchor the dust collector to the floor. **Never install any casters or movable platform to the feet.**
12. **These dust collectors are very heavy.** Do not attempt to lift this unit in any way without the use of an approved lifting devise such as a hoist, lift truck or crane. Lifting this unit by hand can cause a severe back injury.
13. **These dust collectors should not be used to collect both saw dust *and* metal dust.** Hot metal embers or chips could ignite saw dust in the drums below the cyclone and/or dust bag. Any used or reclaimed wood should be checked for hidden or embedded metal nails, screws or fasteners before machining to eliminate any metal pieces going into the drums with any wood dust. This type wood should first be checked with a magnet.

Unpacking

CAUTION: The blower/motor assembly ② (see Fig. 1 on page 5) is very heavy. Use a fork lift, hoist or crane to remove it from the carton. Lifting this assembly by hand could cause a severe back injury.

Remove all dust collector components from the shipping containers. Compare parts list below to parts pictured in Fig. 1 on page 5. Check for missing or damaged parts. Notify supplier if any parts are missing or damaged.

NOTE: SAVE ALL THE CARDBOARD PACKAGING FOR USE DURING ASSEMBLY OF DUST COLLECTOR.

TOOLS AND ADDITIONAL PARTS NEEDED TO ASSEMBLE DUST COLLECTOR

- Fork lift truck or hoist with minimum lift height of 9 feet and minimum load capacity of 750 pounds.
 - Lifting straps or chains with minimum live load capacity of 750 pounds.
 - Step ladder approved for minimum working height of 10 feet.
 - Level (1).
 - Ratchet wrench (1).
 - 3/4" Socket, 3/4" open end or box end wrench (1 of each).
 - 9/16" Socket, open end or box end wrench (1 of each).
 - 3/8" Socket, open end or box end wrench (1 of each).
 - 5/16" Socket, open end or box end wrench or flat blade screw driver to tighten hose clamps (1).
-
- Two, 55 gallon, open top, steel drums (not included).
 - Starting switch, power cable and any other components required by code to make electrical connections.
 - Six floor anchors with minimum holding capacity of 250 pounds each.

Parts List for Parts Pictured in Fig. 1 on Page 5

Part Reference Number	Quantity Required	Part Description
1	1	Cyclone separator / Inlet chip deflector assembly
2	1	Blower housing, motor, motor mounting plate and wheel assembly
3	1	Discharge transition
4	6	Vertical support leg, 2" x 2" x 1/4" angle iron, 42-1/2" long
5	1	Vertical bag support, 2" x 2" x 1/8" angle iron, 47-1/4" long
6	1	Horizontal bag support, 2" x 2" x 1/8" angle iron, 47-1/4" long
7	1	Bag cross brace, 2" x 2" x 1/8" angle iron, 24" long
8	3	Support leg foot
9	1	Bag flat tie brace, 1-1/2" wide flat steel, 46" long
10	3	Support leg cross brace, 2" wide flat steel, 30-1/4" long
11	1	Air flow diverter (For 7-1/2 Horse Power Model ONLY)
12	1	Filter bag (packed in separate plastic bag)
13	1	Drum lid assembly
14	1	Flex hose, 7" x 24" long

Other Parts (Parts without reference numbers are not pictured on page 5)

In Plastic Zip Lock Bag		
15	3	(1) Dust bag clamp and (2) Hose clamps
—	1	Adhesive rubber gasket for cyclone separator, 1/2" wide x 1/8" thick x 69" long
—	1	Adhesive rubber gasket for drum lid, 1-1/4" wide x 1/4" thick x 79" long
—	1 Tube	RTV Silicone Sealant, Dow Corning #732

In Box # 31395 (Contains all assembly hardware)		
—	7	1/2" UNC, Hex head bolts, 1-1/4" long
—	12	1/2" UNC, Hex head bolts, 1-1/2" long
—	3	1/2" UNC, Hex head bolts, 2" long
—	28	1/2" UNC, Hex nuts
—	50	1/2" Flat washers
—	28	1/2" Lock washers
—	8	3/8" UNC, Hex nuts
—	8	3/8" Flat washers
—	8	3/8" Lock washers
—	12	#14 Hex head sheet metal screws

Fig. 1, Parts to be assembled per parts list on Page 4.

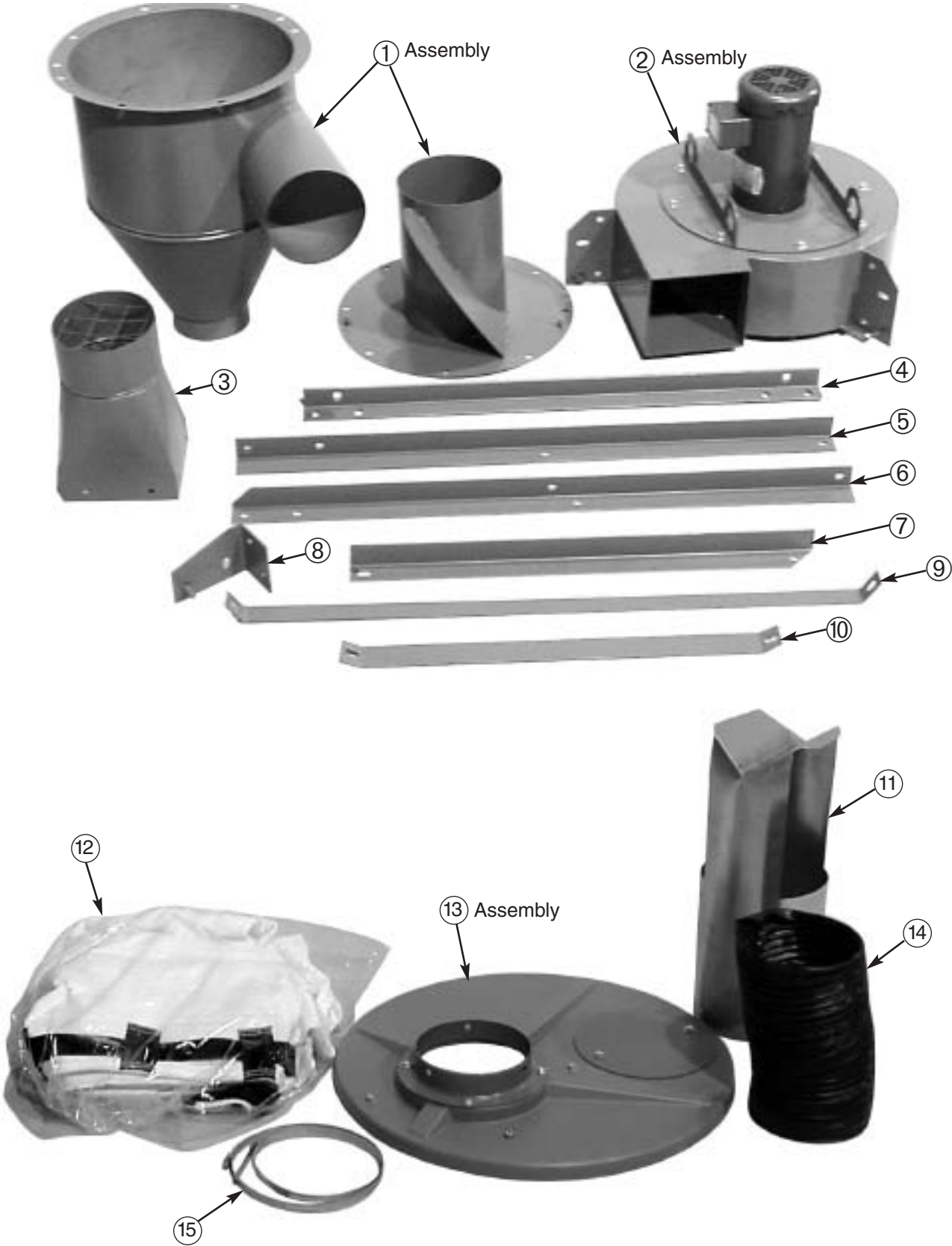

ASSEMBLY INSTRUCTIONS

NOTE: CUT PACKAGING CARDBOARD & PUT ON FLOOR TO PROTECT PAINTED PARTS DURING ASSEMBLY.

STEP 1: Blower / Motor Assembly.

The blower/motor assembly ② is shipped as a pre-assembled unit that includes the blower housing, blower wheel, motor and the motor mounting plate. **Weight is over 250 pounds.**

CAUTION:

This assembly is very heavy. Use a fork lift, hoist or crane to remove this unit from the carton. Lifting this unit by hand could cause a severe back injury.

Set the assembly ② on the floor (on cardboard) in position as shown in Fig. 2.



▲Fig. 2

STEP 2: Cyclone Separator / Inlet Chip Deflector.

The cyclone separator and inlet chip deflector ① are pre-assembled at the factory using two studs with washers and nuts. **DO NOT unbolt these two parts.** Place this assembly on the floor (on cardboard) as shown in Fig. 4.



▲Fig. 3

STEP 3: Apply Gasket to Inlet Chip Deflector.

Remove a few inches of the paper backing from the $\frac{1}{2}$ " wide x $\frac{1}{8}$ " thick rubber gasket material. Start applying the gasket to the outer edge of the chip deflector ① as shown in Fig. 4 until a *complete circle* is formed. Cut off any excess. **NOTE:** The purpose of this gasket is to prevent air leakage into the blower. If the gasket is not installed properly, sound levels will also increase during operation.



▲Fig. 4

STEP 4: Installing Cyclone/Chip Deflector assembly ① to the Blower/Motor assembly ②.

Gently tilt blower up on top of motor per Fig. 5. There are 8 threaded studs on the inlet side of the blower assembly ②. Remove the protective sleeves from the studs. Align the eight holes in the cyclone/chip deflector assembly ① with the threaded studs as shown in Fig. 5. **NOTE: The inlet tube of the cyclone should be pointing in the opposite direction to the blower discharge.** Install (8) $\frac{3}{8}$ " flat washers, lock washers and nuts onto the studs and tighten. **Gently** tilt housing back onto its side as in Fig. 2.

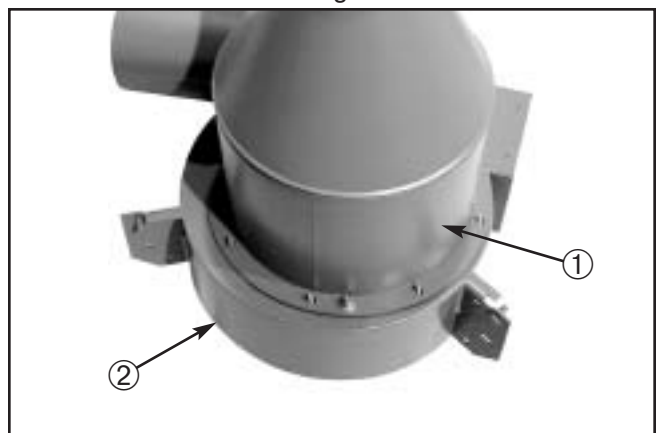

▲Fig. 5

NOTE: All six leg sections ④ are 42½" long, 2" x 2" x ¼" angle iron, identical at both ends.

STEP 5: Installing Upper Leg Section to Blower Housing assembly.

Assemble one leg section ④ onto threaded bolt that is welded to the housing lug as shown in Fig. 6. Install one ½" x 1½" long bolt with a flat washer into the other hole. Install two flat washers, two lock washers and two nuts onto both bolts. **Hand tighten nuts at this time.** Make sure single slot (AA) in leg section is facing outward as shown.

Assemble two more upper leg sections to the two remaining housing lugs in the same manner.

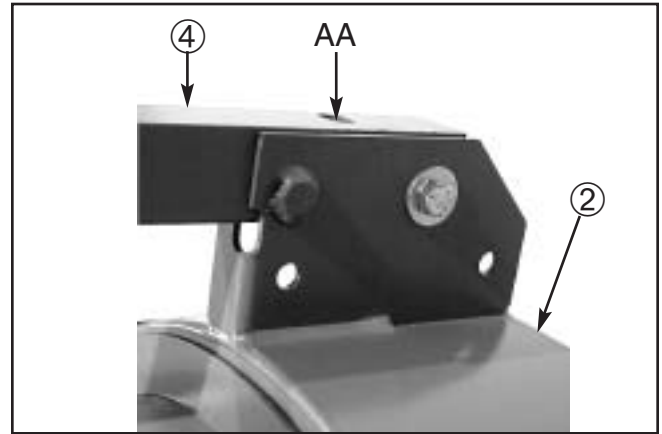

▲Fig. 6

STEP 5A: Upper Leg section to Housing assembly.

Fig. 7 illustrates all upper legs assembled to the blower housing.

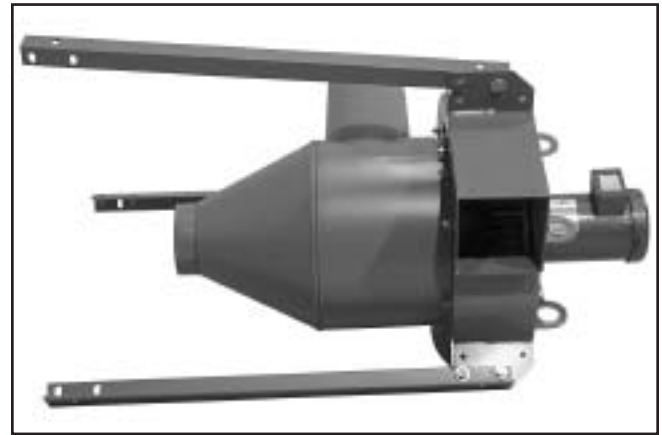

▲Fig. 7

STEP 6: Installing Lower Leg Section to Upper Leg Section.

Assemble lower leg section ④ over upper leg leg section ④ as shown in Fig. 8.

IMPORTANT: Lower leg section (A2) must overlap the upper leg section (A3). Install two ½" x 1½" long bolts into holes (BB) with four flat washers, two lock washers and nuts.

Hand tighten nuts at this time.

Leave slot (CC) open. Assemble two more lower leg sections to the other two upper leg sections in the same manner.

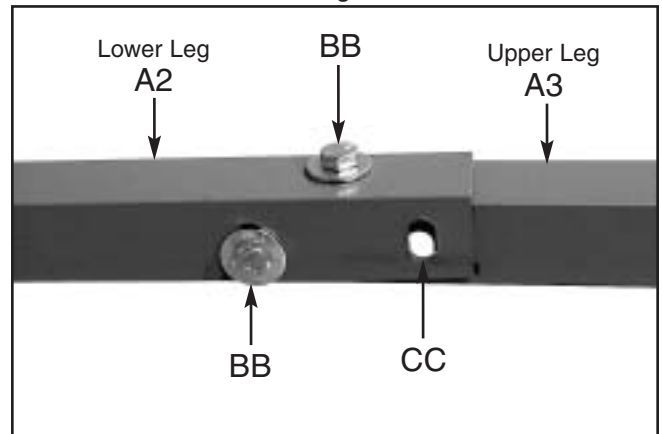

▲Fig. 8

STEP 7: Installing Support Braces to Leg assembly.

Cross braces are 2" wide and 30¼" long.

IMPORTANT: Two support leg cross braces ⑩ in Fig. 9 must be assembled to one leg section at the same time for proper assembly. Place one cross brace on the outside of the leg assembly and one cross brace on the inside of the same leg assembly at location CC. Install one ½" x 2" long bolt with two flat washers, one lock washer and one nut.

Hand tighten nut at this time.

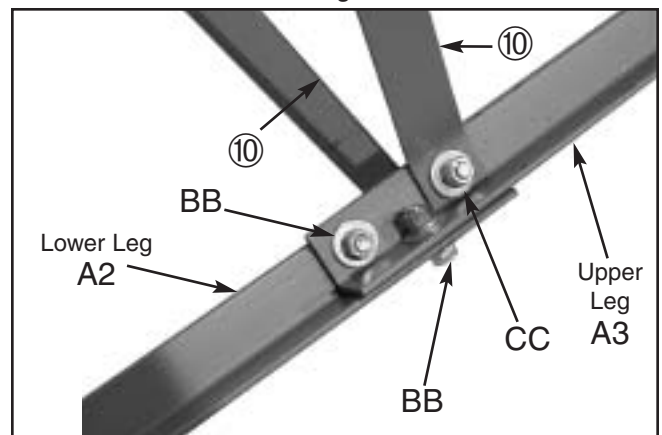

▲Fig. 9

STEP 7A: Leg Cross Brace assembly.

All three cross braces should be attached in the same manner at each leg section as shown in Fig. 10.

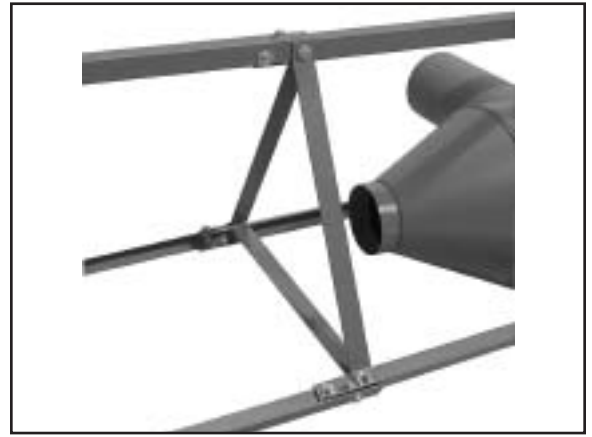

▲Fig. 10

STEP 8: Installing Support Leg Feet.

Install support leg foot ⑧ onto one lower leg section as shown in Fig. 11. Fasten with one ½" x 1½" long bolt with two flat washers, one lock washer and one nut. Add one flat washer, one lock washer and one nut onto the stud. **Hand tighten nuts at this time.** Assemble the two other support leg feet in the same manner.

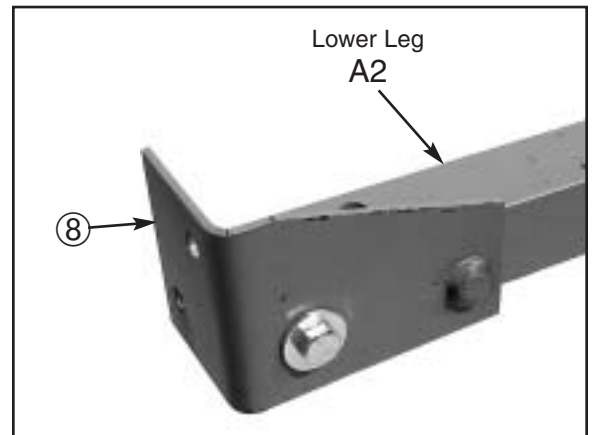

▲Fig. 11

STEP 9: Installing Discharge Transition.

Apply a bead of RTV silicone sealant (supplied with the unit) to all four sides of the blower discharge as shown in Fig. 12. This will ensure an airtight seal that will prevent air leakage and increased sound levels during operation.



▲Fig.12

STEP 9A: Attaching Discharge Transition.

Position discharge transition ③ over outside of blower discharge as shown in Fig. 13. Align the holes on the transition with the pre-drilled holes in the blower discharge. Fasten with eight #14 x ½" hex head screws (2 on each side at locations DD.)

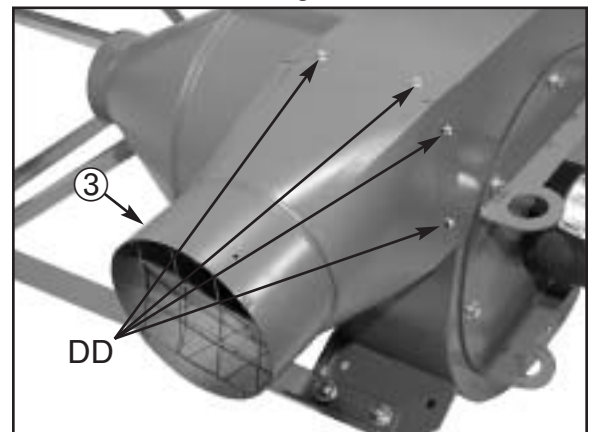

▲Fig.13

STEP 10: Lifting the dust collector.

- a. Position the dust collector on the floor, with the two legs nearest the motor resting on the floor.

CAUTION: the dust collector can be raised mechanically or manually. Because of the weight of the dust collector, we strongly recommend using a forklift, hoist or crane with guide ropes to set the unit upright.

- b. **IMPORTANT:** Attach a sling or cable, with at least a 750 pound live load capacity, to the lifting eyes on the blower side plate as shown in Fig. 14. Using guide ropes, carefully raise the dust collector to an upright position on the floor.
- c. Without removing the lifting sling or cable and keeping the sling or cable taut, carefully check the alignment of the blower housing and feet. The blower housing should be level with the feet adjusted to the floor surface.
- d. **IMPORTANT: Carefully loosen all the mounting hardware for the three legs from the blower housing down to the feet, including the leg cross braces. After you have leveled the unit with the floor surface, completely tighten all the hardware at each location.**

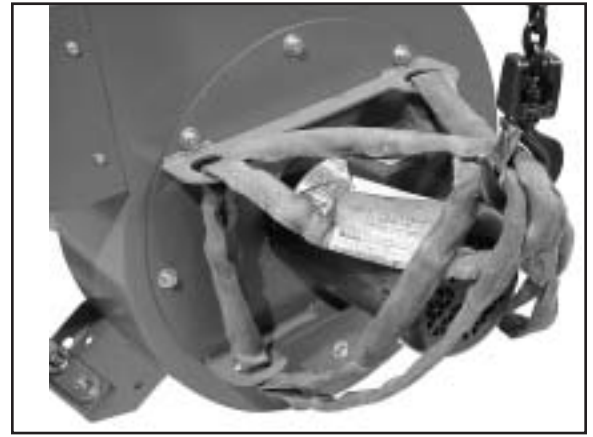

▲Fig. 14

WARNING:

DO NOT assemble any casters to the feet, as they will affect the stability of the dust collector and create a hazard. After the dust collector is in its final position, the holes provided in the feet should be used to anchor the dust collector to the floor.

STEP 11: Installing the Vertical Dust Bag Support.

The vertical bag support ⑤ is 2" x 2" x 1/8" angle iron, 47 1/4" long with 4 holes. Install it to the blower housing mounting lug at the bottom of the blower discharge. Attach with two 1 1/4" long bolts, four flat washers, two lock washers and two nuts as shown in Fig. 15. Make sure this section is vertical, then tighten the nuts.

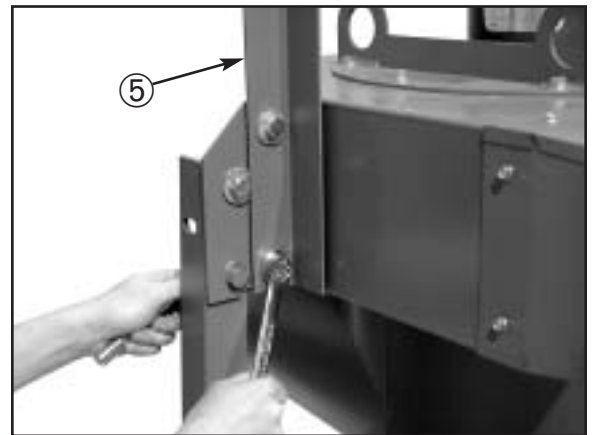

▲Fig.15

STEP 12: Installing other Bag Supports & Braces.

- a. The horizontal bag support ⑥ is 2" x 2" x 1/8" angle iron, 47 1/4" long with 5 holes and mitered at one end. Bolt the square end with one hole to the vertical bag support ⑤ with a 1/2" x 1 1/4" bolt, two flat washers, one lock washer and one one nut at location EE in Fig. 16.
- b. Bolt the 2" x 2" x 1/8" angle cross brace ⑦ to the vertical support ⑤, using the round hole at the mitered end. Use the same size hardware as step "a" above.
- c. Bolt the other end to the horizontal bag support ⑥, at location FF, with a 1/2" x 1 1/4" long bolt, two flat washers, one lock washer and a nut.

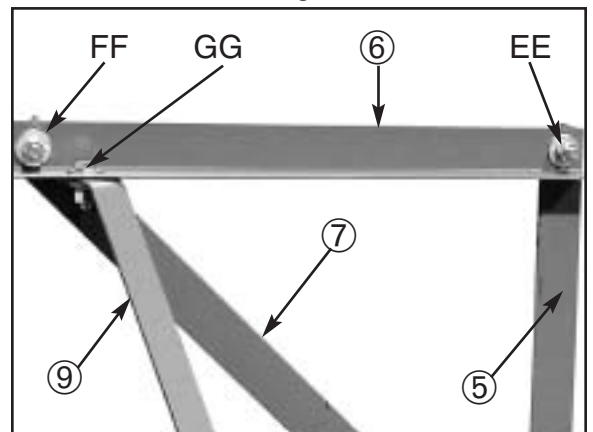

▲Fig.16

STEP 12: Continued from page 9.

- d. The flat brace ⑨ should be bolted to the hole in the horizontal bag support ⑥ at location GG in Fig. 16 on page 9 . Use a ½" x 1¼" bolt, two flat washers, one lock washer and nut.
- e. Bolt the other end of the flat brace ⑨ to the top hole in the blower housing lug at location HH in Fig. 17. Use a ½" x 1¼" bolt, two flat washers, one lock washer and nut.

NOTE: Make sure all hardware is tightened for all the bag support parts.

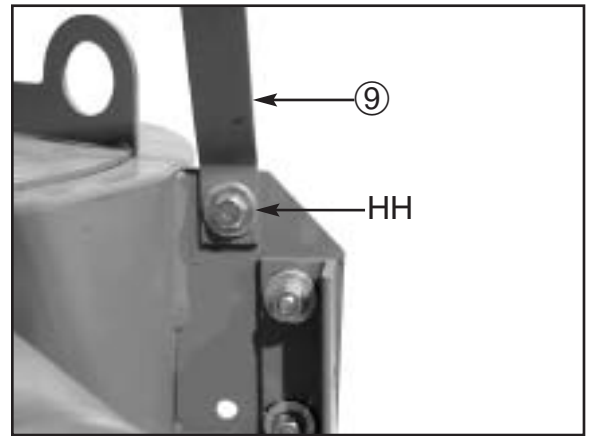

▲Fig. 17

STEP 13: Installing Gasket to Drum Lid Assembly.

- a. Unwind the roll of the 1¼" wide x ¼" thick gasket material and peel the paper backing off for about 6" of one end.
- b. Apply the sticky end onto the underside of the fiberglass drum lid ⑬ with one edge being up against the side lip of the lid as shown in Fig. 18.
- c. Complete the installation of the gasket by pulling off the paper backing and applying the gasket until you have circled the drum lid. Cut off any excess gasket material where they would overlap.



▲Fig. 18

STEP 14: Installing Dust Collector Hose

- a. Place the drum lid from Step 13 on top of a 55 gallon steel drum (not supplied).
- b. See Fig. 19. Adjust two of the three hose clamps ⑮ that were in the plastic bag to about 7½" diameter. Slide one clamp over each end of hose ⑭. Slide one end of the hose over the outlet of the cyclone separator and tighten the clamp. Slide the bottom end of the hose over the inlet collar of the drum lid assembly ⑬ and tighten the clamp.

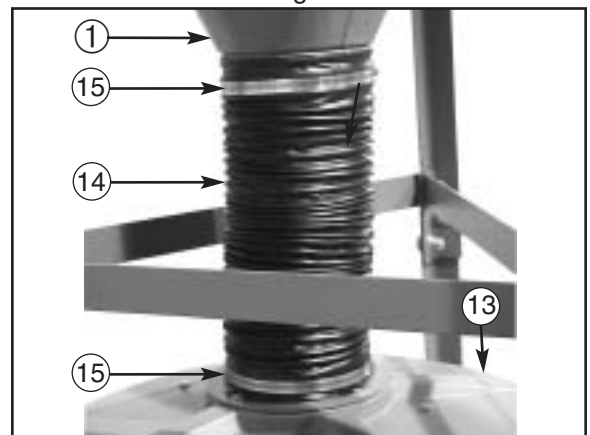

▲Fig.19

STEP 15: Installing the Air Flow Diverter.

NOTE: This step is only for dust collectors with a with a 7½ horsepower motor. For 3 & 5 horsepower models, go on to STEP 16.

- a. Slide the air flow diverter ⑪ over the outlet of the discharge transition ③ with the outlet openings pointing up and down as shown in Fig. 20.
- b. Align the four holes in the diverter with the four holes in the transition. Install four #14 x 1/2" long sheet metal screws through the four holes and tighten.

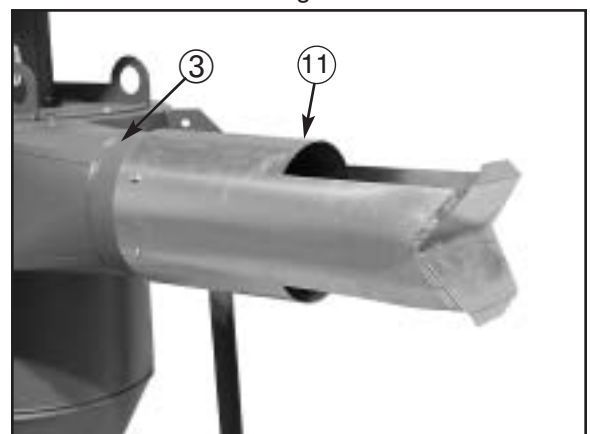

▲Fig.20

STEP 16: Installing the Dust Bag.

Tie the rope in the grommet at the top of the dust filter bag ⑫ through the two holes in the end of the horizontal bag support ⑥.

NOTE: Use a temporary knot to hold filter bag in place.

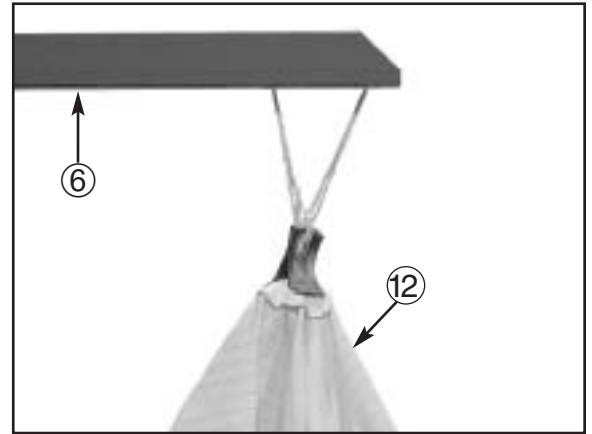

▲Fig. 21

STEP 17: Installing Dust Bag to Air Flow Diverter.

NOTE: This step is only for dust collectors with a with a 7½ horsepower motor. For 3 & 5 horsepower models, go on to STEP 18.

- Take the third remaining clamp ⑮ and adjust it to about 8½" diameter.
- Slide the clamp over the inlet sleeve of the dust bag ⑫.
- Slide the bag inlet sleeve over the air flow diverter ⑪ to within 2" of the screws in Fig. 22.
- Slide the clamp over the dust bag inlet sleeve and tighten the clamp.

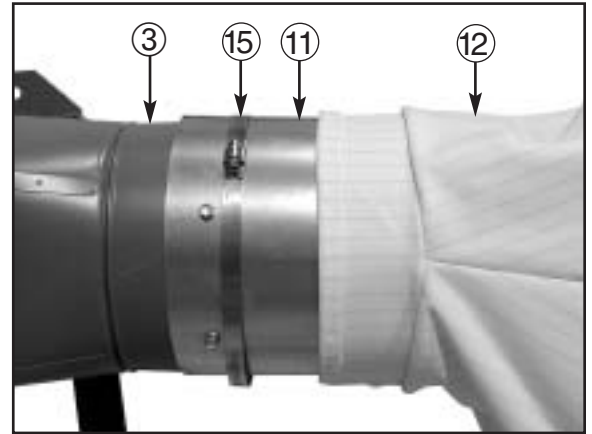

▲Fig. 22

STEP 18: Installing Dust Bag to Discharge Transition.

NOTE: This step is for 3 & 5 horsepower models.

- Take the third remaining clamp ⑮ and adjust it to about 8½" diameter.
- Slide the clamp over the inlet sleeve of the dust bag ⑫.
- Slide the bag inlet sleeve over the discharge transition ③ so the end of the sleeve is at the transition seam as shown in Fig. 23.
- Slide the clamp over the dust bag inlet sleeve and tighten the clamp.

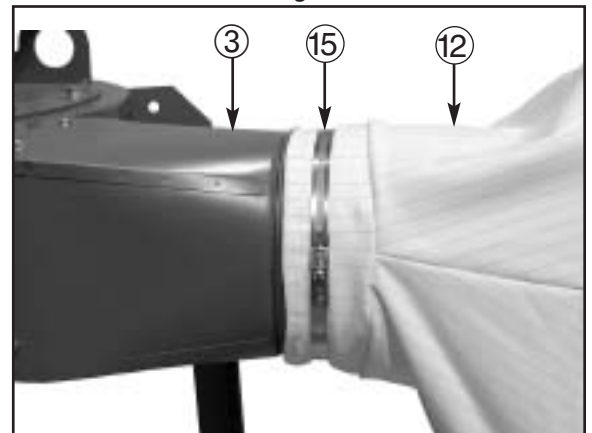

▲Fig.23

STEP 19: Installing Dust Bag over drum.

- Install the large diameter opening of the dust bag ⑫ over the lip of a standard 55 gallon steel drum (not supplied) as shown in Fig. 24.
- Tighten the dust bag belt clamp to hold the bag onto the drum.
- Adjust the rope which was temporarily tied in STEP 16 above so bag does not droop or sag. Retie knot in rope.



▲Fig.24

Connecting Motor to Power Source

NOTE:Your dust collector is supplied with a motor; however, it is not supplied with controls such as switches, starters, power cords or plugs for supplying power to the motor. All wiring for the dust collector must be completed by a licensed electrician. The electrical wiring must be performed in accordance with local and National Electric Codes (NEC). All wiring must comply with all safety standards and be in accordance with the electrical ratings shown on the motor nameplate.

Failure to follow all safety and electrical standards could cause a fire, electrical shock and complete electrocution leading to death.

WARNING

The blower housing contains a high speed radial blade that can amputate fingers, grab loose clothing and neckties, or propel dust at very high velocities. DO NOT OPERATE WITHOUT THE DISCHARGE GUARD AND DUST BAG IN POSITION. DO NOT ATTEMPT TO CLEAN, REMOVE THE DUST BAG, SERVICE THE UNIT OR MOVE THE DUST COLLECTOR WHILE IN OPERATION. ALWAYS DISCONNECT OR LOCK OUT FROM POWER SOURCE FIRST.

WARNING

The blower motor has a motor cooling fan on top of the motor. Do not insert any fingers or objects into the slots in the cooling fan cover. Injury or death could result.

STEP 1: Perform this step ONLY after all the wiring from the controls to the motor has been performed.

- a. You will need to stand on a ladder, approved for the working height necessary to safely stand, and view the top of the motor from above.
- b. Have someone else energize (turn on) the motor for 2 seconds and then turn it off.
- c. As the motor slows down to a stop, look at the cooling fan on the top of the motor through the motor fan cover slots. **The motor fan should be turning in a Counter-Clockwise rotation for the dust collector to provide the proper air flow.**
- d. If, the motor cooling fan is turning in a Clockwise rotation, you will need to disconnect or “lock out” power to the motor and perform the necessary wiring connections to reverse the rotation of the motor.
- e. After you have completed step 1d above, go back and repeat steps 1a through 1c above.

Maintenance

 **WARNING!** Before performing ANY inspection, maintenance or service of any components of the dust collector, be sure that you have disconnected or “locked out” power to the motor to prevent accidental starting.

Steel and Sheet Metal Parts:

Non-air stream parts are maintenance free and should not require any maintenance during the life of the unit. Periodic inspection of all hardware should be performed to assure nothing has come loose. Air stream parts are subject to wear due to erosion caused by dust particles going through the system. Replace any worn parts found during periodic inspections.

Cast Aluminum Blower Wheel:

The cast aluminum blower wheel should be inspected every six (6) to twelve (12) months depending on the amount of use it has undergone. Inspect the wheel for any cracks or excessive wear that could cause wheel unbalance which will cause early failure of the motor bearings. Also, if an unbalanced blower wheel fails during operation, it could cause severe bodily injury and even death. **DANGER! NEVER USE A CRACKED OR EXCESSIVELY WORN BLOWER WHEEL. REPLACE IT.**

Motor Maintenance:

The bearings on the standard motors are sealed and never require lubrication. To remove dust on the motor, blow it off with an air hose. Air pressure above 50 P.S.I. should not be used as it may damage the insulation in the motor, causing excessive temperatures that will affect the life of the motor. The person performing this cleaning function should always wear appropriate eye protective goggles.

Dust Filter Bag

About once a week, after unit is turned off and with personal eye protection on, strike the side of the dust bag with your hand to loosen any dust that has collected in the pores of the bag. Allow dust to settle into the drum and then empty the drum. The standard knit polyester dust bag on the 3-5 HP models can also be washed. When the dust bag becomes so dirty that it greatly reduces airflow, it should be replaced. **Never disconnect the dust bag while the unit is operating.**

Replacement Parts for Standard Central System Dust Collectors

See Fig. 25 on page 14 for reference numbers.

NOTE: Some part reference numbers (Ref. No.) on this page and page 14 are different from numbers on page 4.

Ref. No.	Description	Part Numbers for Each Model			Qty. Per Unit
		3 HP Model	5 HP Model	7-1/2 Model	
1	Horizontal bag support	03000141	03000141	03000141	1
2, 2A	Motor mounting plate	Consult factory, unit serial number will be required.			1
3, 3A	Motor	Consult factory, unit serial number will be required.			1
4	Vertical bag support	03000143	03000143	03000143	1
5	Bag support cross brace	03000142	03000142	03000142	1
6	Bag flat tie brace	03000144	03000144	03000144	1
7	Blower wheel	Consult factory, unit serial number will be required			1
8	Blower housing	34898	34898	34898	1
9	Discharge transition	51272	51272	51272	1
10	Air flow diverter	—	—	51288	1
11	Vertical support leg	03000091	03000091	03000091	6
12	Dust bag clamp	31019	31019	31019	1
13	Support leg cross brace	03000092	03000092	03000092	3
14	Inlet chip deflector	34756	34756	34756	1
15	Filter bag	25081	25081	—	1
	Filter bag	—	—	25209	1
16	Cyclone separator	51273	51273	51273	1
17	Support leg foot	03000093	03000093	03000093	3
18	Hose clamp	31019	31019	31019	2
19	Flex hose	31387	31387	31387	1
20	Drum lid assembly	26377	26377	26377	1
●	Gasket kit (Not shown)	▲	▲	▲	1

▲ All hardware is standard type available at any local hardware store.

Hardware Required

A	1/2-13UNC x 1-1/4" Hex head bolt	▲	▲	▲	7
	1/2" Flat washer	▲	▲	▲	14
	1/2" Lock washer	▲	▲	▲	7
	1/2-13UNC Hex nut	▲	▲	▲	7
B	3/8" Flat washer	▲	▲	▲	8
	3/8" Lock washer	▲	▲	▲	8
	3/8-16UNC Hex nut	▲	▲	▲	8
C	3/8-16UNC or 1/2-13UNC x 3/4" Hex head bolt	▲	▲	▲	4
	3/8" or 1/2" Lock washer	▲	▲	▲	4
D	1/2-13UNC x 1-1/2" Hex head bolt	▲	▲	▲	9
	1/2" Flat washer	▲	▲	▲	18
	1/2" Lock washer	▲	▲	▲	9
	1/2-13UNC Hex nut	▲	▲	▲	9
E	1/2" Flat washer	▲	▲	▲	9
	1/2" Lock washer	▲	▲	▲	9
	1/2-13UNC Hex nut	▲	▲	▲	9
F	#14 x 1/2" Sheet metal screws	▲	▲	▲	8
	#14 x 1/2" Sheet metal screws	—	—	—	4
G	1/2-13UNC x 2" Hex head bolt	▲	▲	▲	3
	1/2" Flat washer	▲	▲	▲	6
	1/2" Lock washer	▲	▲	▲	3
	1/2-13UNC Hex nut	▲	▲	▲	3
H	3/8" Flat washer	▲	▲	▲	8
	3/8" Lock washer	▲	▲	▲	8
	3/8-16UNC Hex nut	▲	▲	▲	8
I	3/8-16UNC x 1" Hex head bolt	▲	▲	▲	4
	3/8" Flat washer	▲	▲	▲	8
	3/8" Lock washer	▲	▲	▲	4
	3/8-16UNC Hex nut	▲	▲	▲	4

▲ All hardware is standard type available at any local hardware store.

Fig. 25 - Replacement Parts Illustration for Parts List on Page 13.

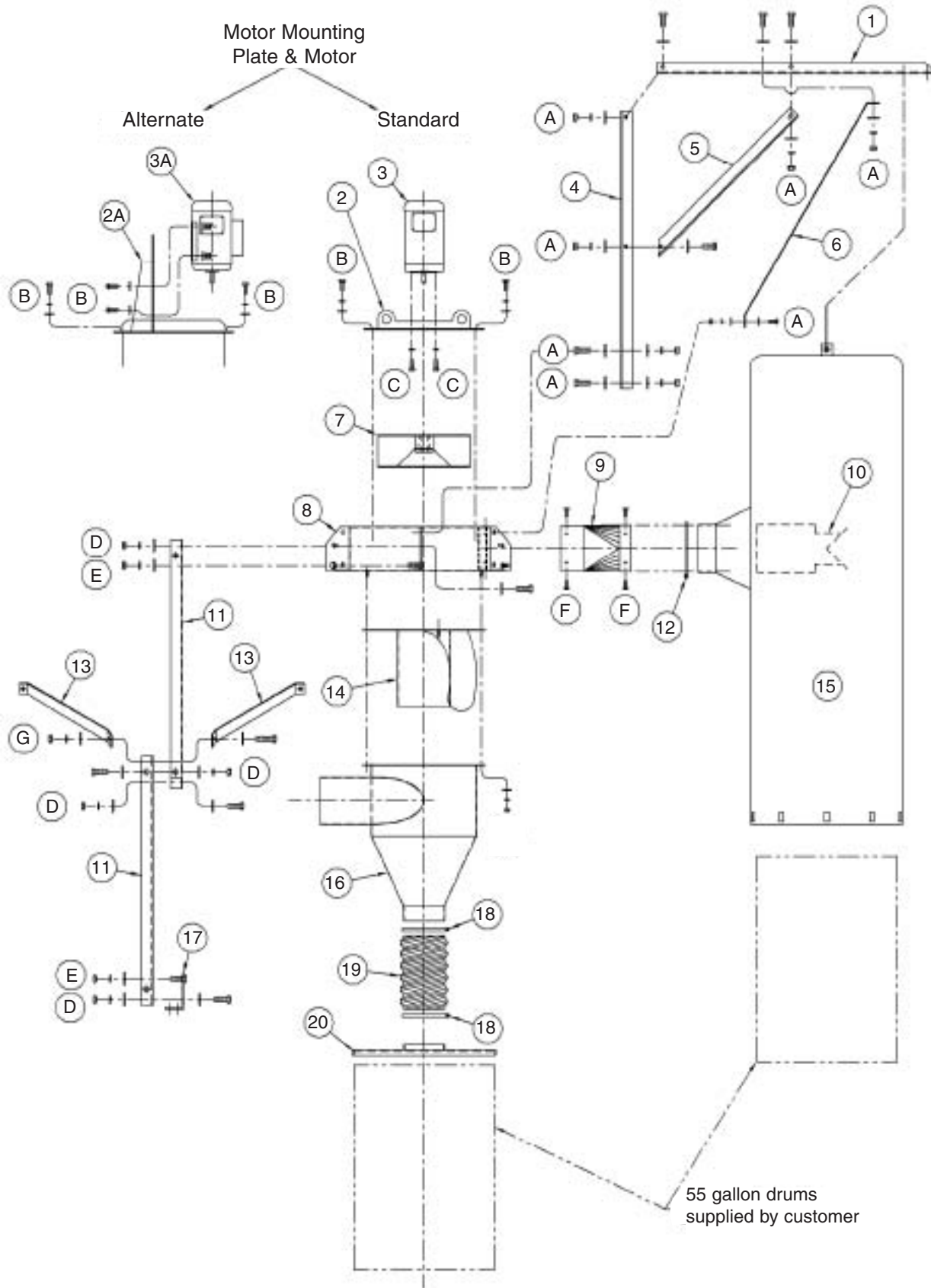

TROUBLESHOOTING GUIDE

⚠️ WARNING! BEFORE attempting to perform ANY of the Corrective Action steps below, make sure that power to the motor has *first* been properly disconnected or locked-out to prevent accidental starting. Failure to do so can cause bodily injury and death.

Symptom	Possible Causes	Corrective Action
Unit will not run.	<ol style="list-style-type: none"> 1. Improper electrical connection. 2. Blower wheel loose. 	<ol style="list-style-type: none"> 1. Assure unit is wired correctly and connected to a live power line with good fuses. 2. Remove cyclone separator section from inlet to blower housing. Check wheel to make sure it is not loose on motor shaft. If it is loose, replace both set screws in the wheel hub with "knurled cup point set screws with a nylon locking patch". Tighten set screws to 100 inch pounds on 3 Horsepower models and to 155 inch pounds on all other models. NOTE: Setscrews can never be tightened more than once. Replace wheel if unable to keep it tight on the shaft.
Air flow too low.	<ol style="list-style-type: none"> 1. Incorrect motor rotation. 2. Duct too small or too long. 3. Dirty dust bag. 	<ol style="list-style-type: none"> 1. Turn off unit and observe the motor cooling wheel on top of the motor as it stops. Correct rotation is Counter Clock-wise. Rewire motor leads as needed to change to the correct rotation. 2. Review duct design with engineer or duct supplier. Make changes as necessary. 3. Clean dust bag. See procedure in "Maintenance" on page 12. If dust bag is excessively dirty and can no longer be cleaned, replace the dust bag.
Dust leaking.	<ol style="list-style-type: none"> 1. Air pressure too high within dust bag. 2. Dust finer than 5 microns. 	<ol style="list-style-type: none"> 1. Install air flow diverter (Per STEP 17, Fig. 22, page 11) to at filter bag.reduce air flow pressure on sidewall of bag. 2. Replace with 1 micron dust bag. NOTE: 1 micron bag is standard on 7-1/2 Hp model.
Noise level.	<ol style="list-style-type: none"> 1. Air leaking between blower housing 2. Air leaking at connection between blower discharge and transition. 3. Air leaking at any duct joints. 	<ol style="list-style-type: none"> 1. Replace gasket between cyclone separator and blower too high.and cyclone separator.housing. See STEP 3, Fig. 4, page 6. 2. Reseal joint (with RTV sealant) between blower discharge and transition. See STEP 9 and 9A, Fig. 12&13 on page 8. 3. Apply RTV sealant at any joint in the duct work that is leaking.
Motor appears.	<ol style="list-style-type: none"> 1. Dirt accumulation on motor. 2. Motor pulling to many AMPS. 3. Motor temperature may be okay as normal motor operation results in a surface temperature too hot to touch. 	<ol style="list-style-type: none"> 1. Blow off excessive dirt. See procedure in "Maintenance" to be too hot.on page 12. 2. Check actual amp draw of motor leads and compare them to AMPS shown on motor nameplate. Actual running amps should be lower than nameplate amps. 3. Check motor surface temperature with a contact pyrometer. Normal temperature is 170-175° F.

Date Performed	Service Performed

Performance Curves

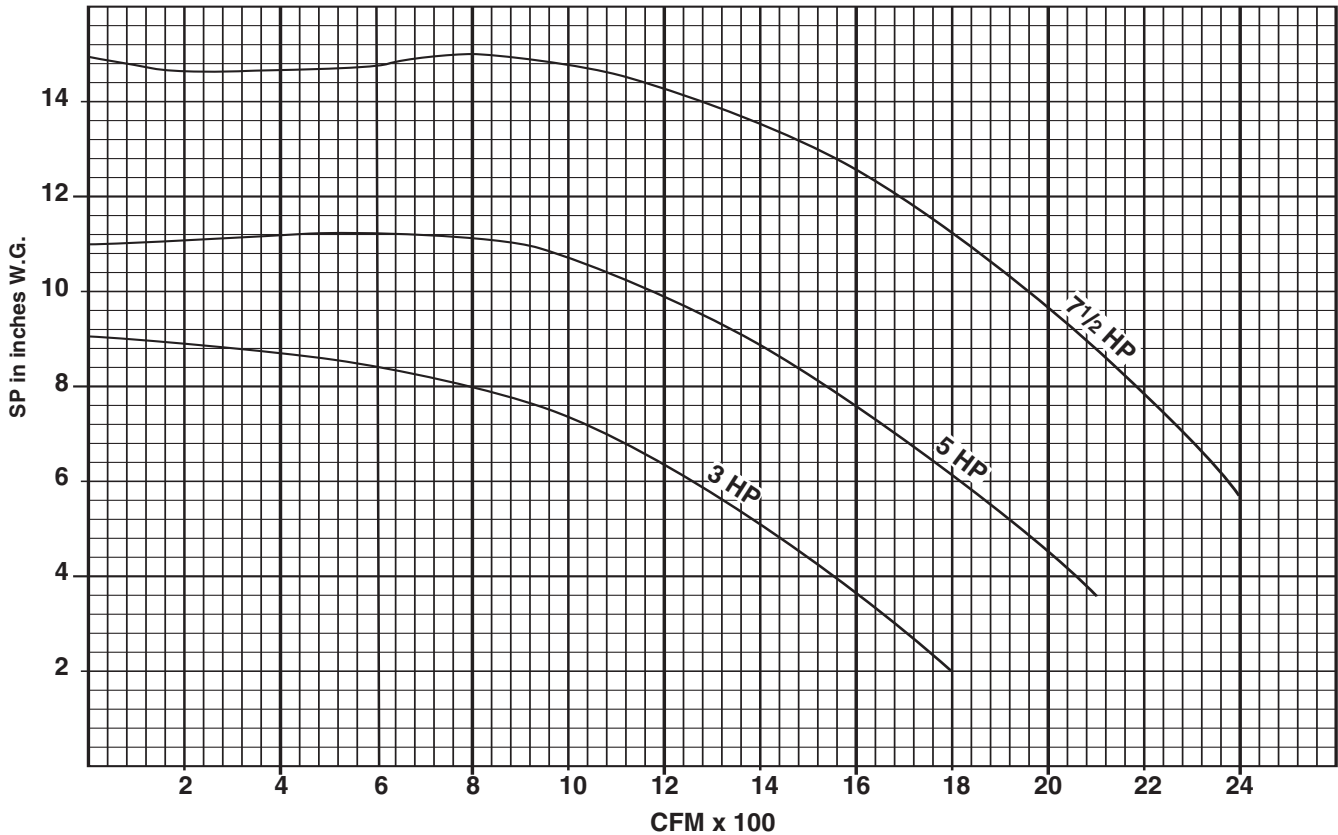

LIMITED WARRANTY

The Seller warrants products of its own manufacture against defects of material and workmanship under normal use and service for a period of eighteen (18) months from date of shipment or twelve (12) months from date of installation, whichever occurs first. This warranty does not apply to any of Seller's products or any part thereof which has been subject to ordinary wear and tear, accident, abuse, misuse, overloading, negligence or alteration. This warranty does not cover systems or materials not of Seller's manufacture. Expenses incurred by Buyer(s) in repairing or replacing any defective product will not be allowed except where authorized in writing and signed by an officer of the Seller.

The obligation of the Seller under this warranty shall be limited to repairing or replacing F.O.B. Seller's plant, or allowing credit at Seller's option. ***This warranty is expressly in lieu of all other warranties expressed or implied including the warranties of merchantability and fitness for use and of all other obligations and liabilities of the seller. The buyer acknowledges that no other representations were made to him or relied upon him with respect to the quality or function of the products herein sold.***

The Seller shall not be liable for any special, direct, indirect, or consequential damages to Buyer(s) or anyone else by reason of any loss or any damage to any property or material processed by Buyer(s) with the products or on account of the character or quality of any property or material processed by Buyer(s) with the product. On products furnished by Seller, but manufactured by others, such as motors, Seller extends the same warranty as Seller received from the manufacturer thereof.

RETURNS

The Seller assumes no responsibility for material returned to our plant without our permission. An RMA (Return Material Authorization) number must be obtained and clearly shown on the outside of the carton and shipments must be freight prepaid. Failure to comply will result in refusal of any shipment at our receiving department.



All fans & blowers shown have rotating parts and pinch points. Severe personal injury can result if operated without guards. High electrical voltage can cause severe injury or death. Disconnect from power source and let motor come to a complete stop before servicing.

Read operating instructions.