

cincinnati fan
OEM and Industrial Air Handling Specialist

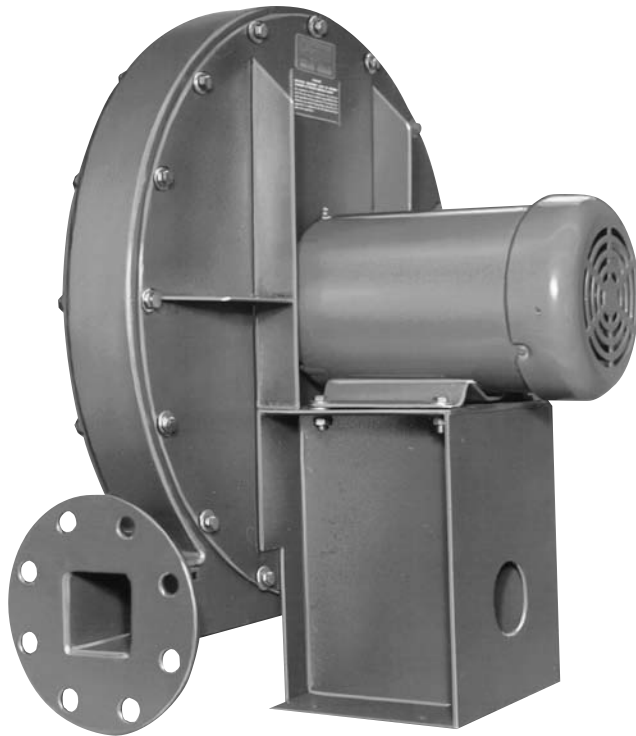

HP SERIES I

**HIGH
PRESSURE
BLOWERS**

7697 Snider Road, Mason, OH 45040-9135

Telephone: 513-573-0600

Visit us at www.cincinnati.com for more information.

Cat. No. HP-I-107
Supersedes HP-1-803



Cincinnati fan

A Company That Stands Behind Its Product

Since the founding of **Cincinnati Fan** in 1956, the company's mission has been to provide quality products at competitive prices, backed by dependable service.

This mission is carried out by specializing in the market for industrial air handling products up to 125 HP. But specialization does not mean the product line is small. **Cincinnati Fan** offers a wide variety of standard and customized products, production flexibility, and customer responsiveness.

Cincinnati Fan has over 170 experienced sales engineers across the U.S. and Canada ready to serve your air handling needs.

Cincinnati Fan can provide:

- Technical evaluation for correct performance conditions.
- Review of air stream and ambient conditions that require special attention.
- Selection of proper components to meet required design specifications.
- Selection of proper accessories.
- System analysis for proper fan design.

Cincinnati Fan operates in a modern facility specifically designed for world class manufacturing enabling us to build standard products to order, including accessories, and ship within 10 working days.

With support like this, you can be sure your **Cincinnati Fan** product will be well-built and will provide maximum dependability and longevity.

Visit us at www.cincinnati-fan.com for more information.

SPECIFICATIONS FOR HP SERIES I BLOWERS

Radial bladed pressure blowers shall be Cincinnati Fan HP, Series I, Model _____, Arrangement _____ Capacity: _____ CFM, _____ Static Pressure at standard conditions. Operating conditions: _____ °F, _____ Ft. Altitude.

Wheels shall be 319 cast aluminum with integral cast hub and blades. Wheels shall be dynamically balanced to assure smooth operation. Fan motor and bearing vibration levels shall not exceed 1.5 mils displacement at 3450 RPM. Shafts shall be turned, ground and polished steel (or stainless steel). All fan shafts shall receive a rust preventive coating prior to shipment. All fans shall be test run at factory before shipping.

Construction gauges shall be as shown in Cincinnati Fan's HP, Series I catalog. The blower housing shall be continuously welded and supported to prevent pulsation at all conditions. Fan bearings shall be grease-lubricated, heavy-duty, self-aligning ball bearings mounted in cast iron pillow blocks. V-belt drives shall be selected for a minimum of 1.3 times nominal horsepower.

All parts in contact with airstream shall be standard steel, aluminum or stainless steel as specified.

Before painting, steel parts shall be cleaned by detergent wash, phosphatized and painted with oven cured gray enamel.

The following accessories shall be included: (See page 4 for available accessories).

THREE STANDARD ARRANGEMENTS

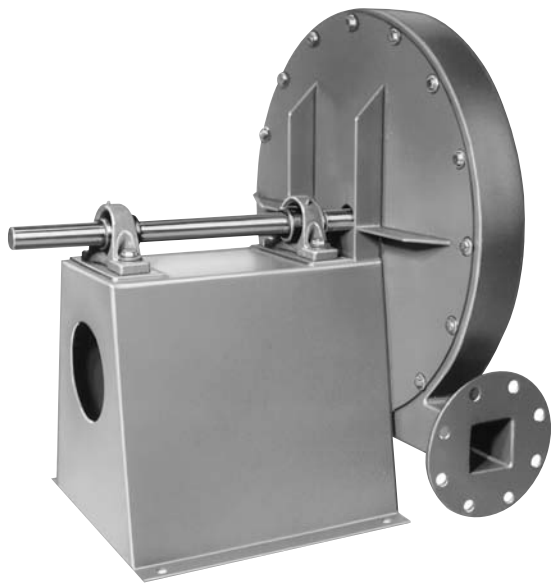

ARRANGEMENT 1 (V-BELT DRIVE)

- Motor not mounted on bearing base.
- Turned, ground and polished shafting assures smooth operation. A rust preventive coating is applied prior to shipment.
- Heavy-duty, self-aligning ball bearings in relubricatable cast-iron pillow blocks. Bearings are selected for optimal performance.
- Maximum temperature of standard design: 200°F; high temperature design up to 400°F.

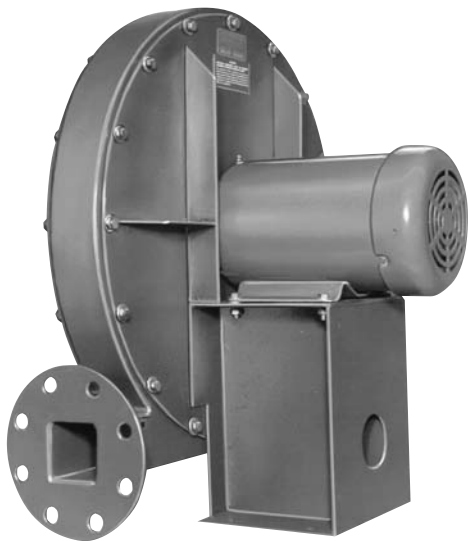

ARRANGEMENT 4 (DIRECT DRIVE)

- Motor mounted on motor base.
- Wheel mounted on motor shaft.
- Maximum temperature of standard design: 200°F; high temperature design not available.

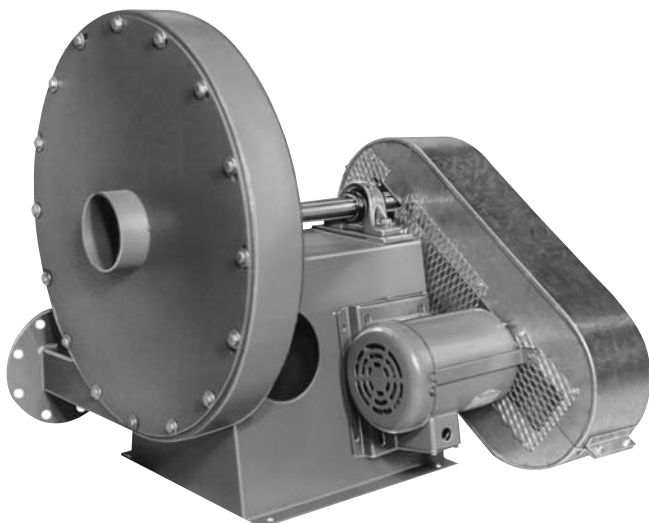

ARRANGEMENT 9 (V-BELT DRIVE)

- Motor mounted on an adjustable slide base on the side of the bearing base.
- Turned, ground and polished shafting assures smooth operation. A rust preventive coating is applied prior to shipment.
- Heavy-duty, self-aligning ball bearings in relubricatable cast-iron pillow blocks. Bearings are selected for optimal performance.
- Maximum temperature of standard design: 200°F; high temperature design up to 400°F.

STANDARD FEATURES FOR ALL HP's



**Teflon
Shaft Seal**



Discharge Flange
Standard ANSI-125/ASA-150
pound hole pattern furnished.
See pages 10 or 11
for dimensions.



Motor Slide Base
(Arrangement 9 only)



Belt Guard
(Arrangement 9 only)
Painted safety yellow.



Cast Aluminum Wheel
(Non-Sparking)

+ PLUS +

- Continuously welded fan housings with removable inlet and drive side plates.
- Blower housings are reversible and rotatable in 45° increments.
- All fans receive a mechanical run test to assure proper balance and alignment before shipping. Arrangements #1 and #9 (less motor) have drive-end key furnished.
- Fan shafts receive a rust preventative coating prior to shipment.
- Arrangement #1 fans offer easy field conversion to arrangement #9 by the addition of a motor slide base.
- Bearings are relubricatable, cast iron, pillow blocks sized for 150,000 hours average life under normal operating conditions. (Excessive belt tension will shorten bearing life).

OPTIONAL ACCESSORIES



Shaft Guard

Shaft guard available on arrangement 1 and 9. Covers bearings and shaft between fan housing and belt guard. Painted safety yellow.



Inlet Filter

Wire mesh or paper cartridge available.



Drain Connection

3/4" pipe coupling welded to lowest point of housing.



Inlet Flange

Standard ANSI-125/ASA-150 pound hole pattern furnished. See page 10 for dimensions.

SPARK-RESISTANT CONSTRUCTION

Type A: All parts in contact with airstream are of nonferrous material. Consult factory.

Type B: The standard wheels are cast aluminum. With the addition of an aluminum ring around the housing shaft opening, the fan will be AMCA type "B" spark resistant. **Maximum Temperature 200°F.**

WARNING

The use of aluminum or aluminum alloys in the presence of steel which has been allowed to rust requires special consideration. Research by the U.S. Bureau of Mines and others has shown that aluminum impellers rubbing on rusty steel may cause high intensity sparking.

The use of the above Standard in no way implies a guarantee of safety for any level of spark resistance. Spark resistant construction also does not protect against ignition of explosive gases caused by catastrophic failure or from any airstream material that may be present in a system.

TEMPERATURE - ALTITUDE CONVERSIONS

Standard Construction: All arrangements suitable to 200°F.

201°- 300°F. Construction: Standard fan with steel wheel. Arrangements 1 and 9 only.

301°- 400°F. Construction: Standard fan with steel wheel, heat slinger and slinger guard. Arrangements 1 and 9 only.

Fan performance tables are developed using standard air which is 70°F., 29.92" barometric pressure and .075 lbs. per cubic foot. Density changes resulting from temperature or barometric pressure variations (such as high altitudes) must be corrected to standard conditions before selecting a fan based on standard performance data.

Temperature and/or altitude conversion factors are used in making corrections to standard conditions.

TEMPERATURE - ALTITUDE CONVERSION FACTORS

AIR TEMP. DEG. F.	ALTITUDE IN FEET ABOVE SEA LEVEL										
	0	1000	2000	3000	4000	5000	6000	7000	8000	9000	10000
0°	.87	.91	.94	.98	1.01	1.05	1.09	1.13	1.17	1.22	1.26
40°	.94	.98	1.02	1.06	1.10	1.14	1.19	1.23	1.28	1.32	1.36
70°	1.00	1.04	1.08	1.12	1.16	1.20	1.25	1.30	1.35	1.40	1.45
80°	1.02	1.06	1.10	1.14	1.19	1.23	1.28	1.33	1.38	1.43	1.48
100°	1.06	1.10	1.14	1.19	1.23	1.28	1.33	1.38	1.43	1.48	1.54
120°	1.09	1.14	1.18	1.23	1.28	1.32	1.38	1.43	1.48	1.53	1.58
140°	1.13	1.18	1.22	1.27	1.32	1.37	1.42	1.48	1.54	1.58	1.65
160°	1.17	1.22	1.26	1.31	1.36	1.42	1.47	1.53	1.59	1.64	1.70
180°	1.21	1.26	1.30	1.36	1.41	1.46	1.52	1.58	1.64	1.70	1.75
200°	1.25	1.29	1.34	1.40	1.45	1.51	1.57	1.63	1.69	1.75	1.81

EXAMPLE:

Select a belt driven HPE to deliver 500 CFM at 18" SP at 160°F., and 7000' altitude.

STEP 1. From the table, conversion factor is 1.53.

STEP 2. Correct static pressure is: 1.53 x 18" SP = 27.5" SP at standard conditions.

STEP 3. Check HP catalog for 500 CFM at 27.5" SP. We select a belt driven HPE and interpolation gives 3463 RPM and 5.61 BHP.

STEP 4. Correct the BHP for the lighter air: $5.61 \div 1.53 = 3.67$ BHP. A 5 HP motor will suffice at 160° F., and 7000' but not at standard conditions. Special motor insulation may be required above 3500 feet altitude. Consult factory.

SUCTION PRESSURE CORRECTIONS

Rarefaction: When air is pulled into a blower inlet (negative pressure) the air molecules are "stretched out", or rarefied, and become less dense than at the blower discharge where the air is compressed.

Catalog ratings may be used directly, without correction, for static pressures defined at the fan discharge. For static pressures defined at the fan inlet (i.e., negative pressures), a correction is typically only made for inlet suction pressures greater than 15" W.G.

The table at the right gives corrected static pressures for suction pressure (rarefaction). These corrected static pressures are for standard air (70°F., 29.92" Hg barometric pressure and .075 lbs. per cubic foot density) at the blower inlet.

If the inlet air temperature and/or altitude are different, make those corrections as shown above and then correct for rarefaction.

Suction Pressure in Inches W.G.	Corrected Static Pressure
16	16.7
18	18.8
20	21.0
22	23.3
24	25.5
26	27.8
28	30.1
30	32.4

DIRECT DRIVE RATINGS @ 3450 RPM

CFM and BHP at Static Pressure Shown • Ratings at 70°F., .075 Density, Sea Level
Performance shown is for fans with inlet and outlet ducts



Model HPA

OUTLET AREA: .063 SQ. FT.
INLET AREA: .120 SQ. FT.

MAXIMUM MOTOR
FRAME: 143T

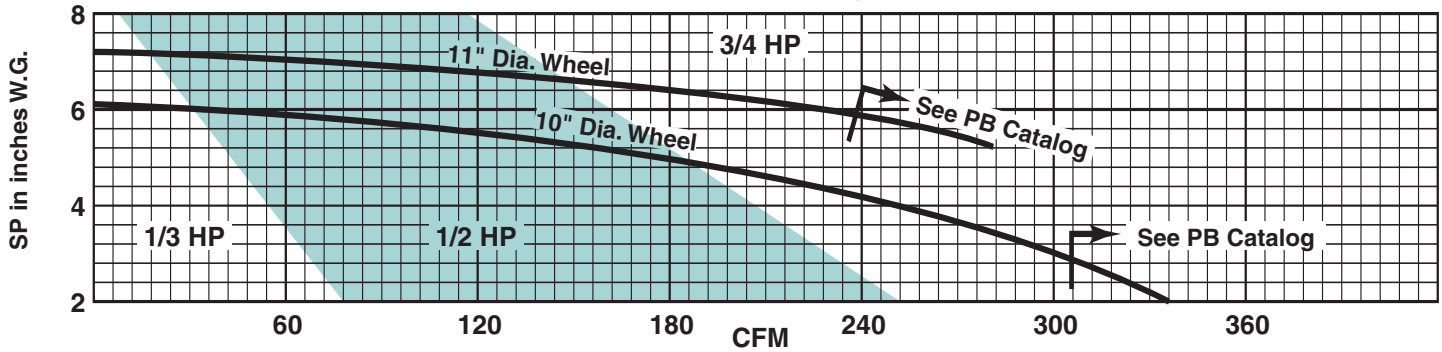

Model HPB

OUTLET AREA: .063 SQ. FT.
INLET AREA: .120 SQ. FT.

MAXIMUM MOTOR
FRAME: 145T

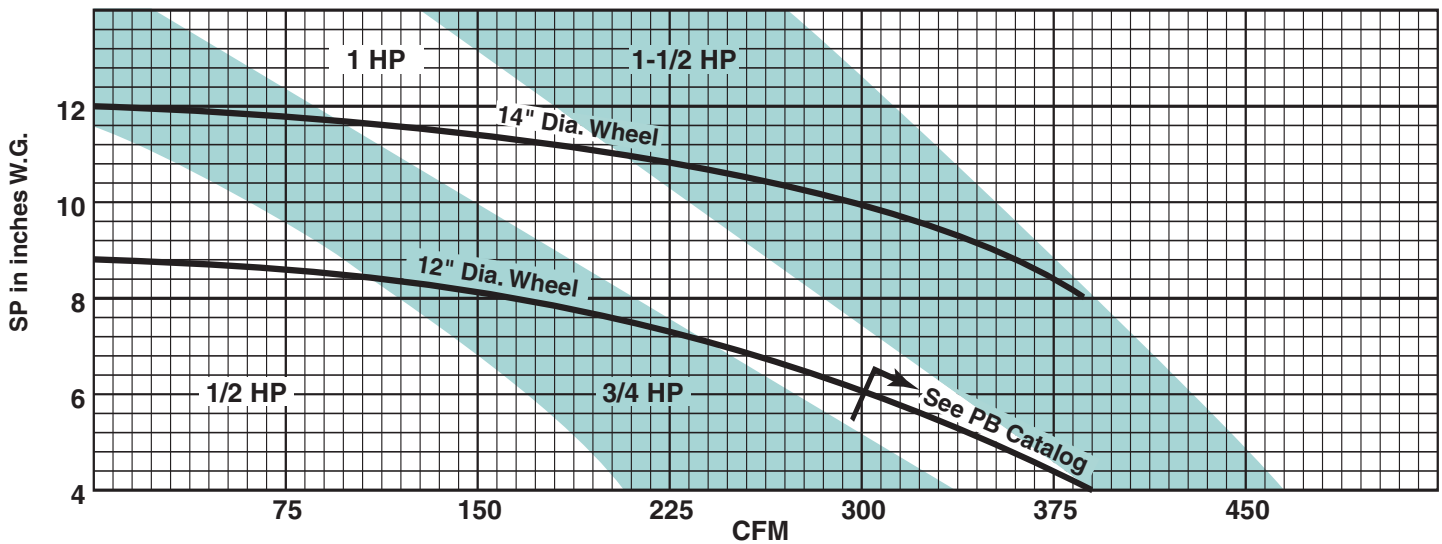

Model HPC

OUTLET AREA: .063 SQ. FT.
INLET AREA: .120 SQ. FT.

MAXIMUM MOTOR
FRAME: 184T

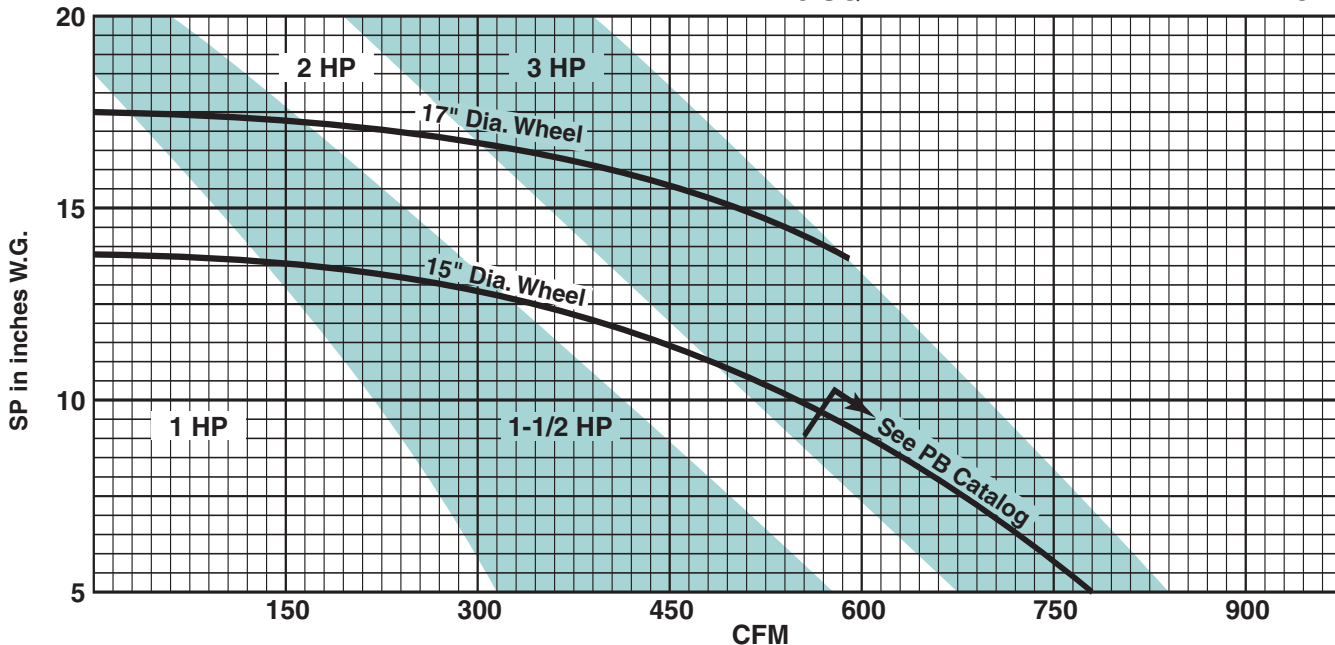

DIRECT DRIVE RATINGS @ 3450 RPM

CFM and BHP at Static Pressure Shown • Ratings at 70°F., .075 Density, Sea Level
Performance shown is for fans with inlet and outlet ducts



Model HPD

OUTLET AREA: .063 SQ. FT.
INLET AREA: .120 SQ. FT.

MAXIMUM MOTOR
FRAME: 184T

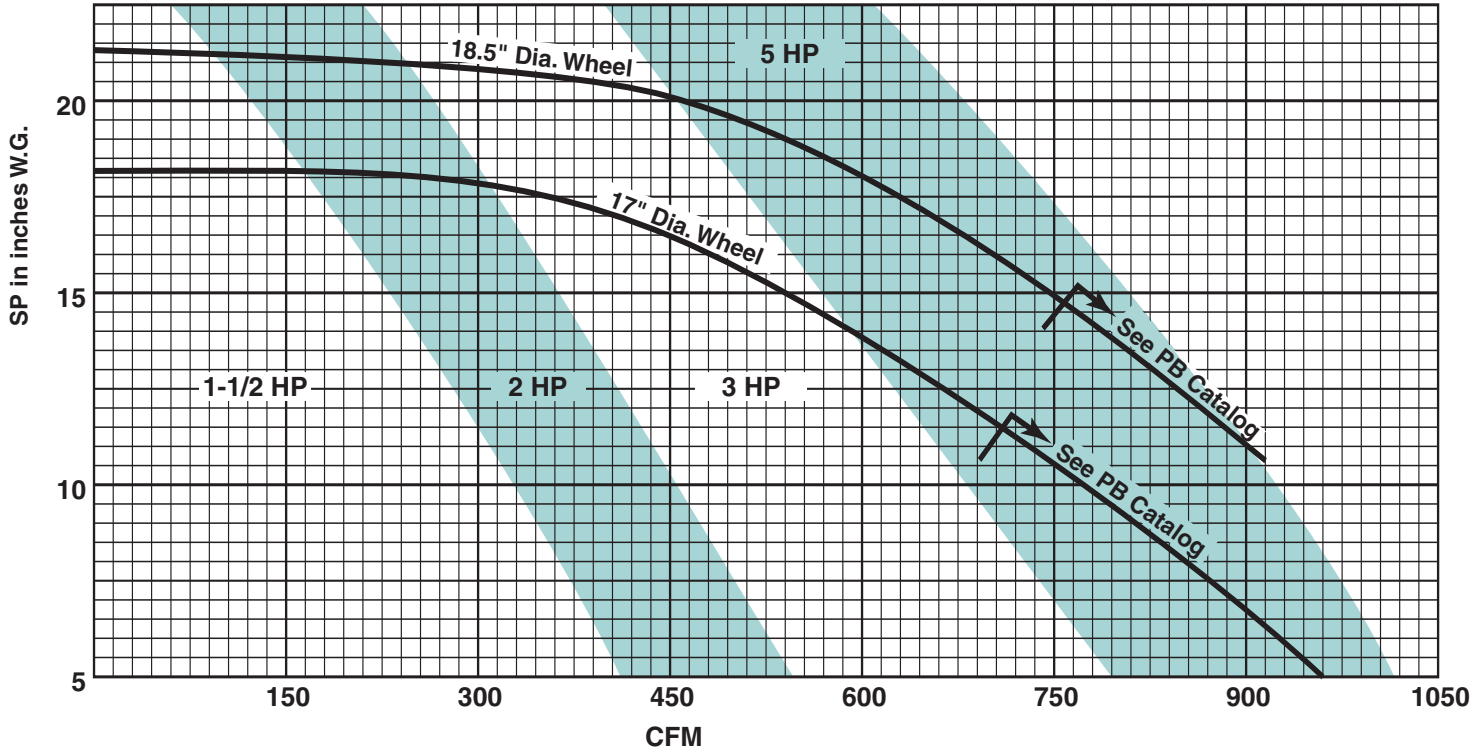

Model HPE

OUTLET AREA: .063 SQ. FT.
INLET AREA: .120 SQ. FT.

MAXIMUM MOTOR
FRAME: 215T

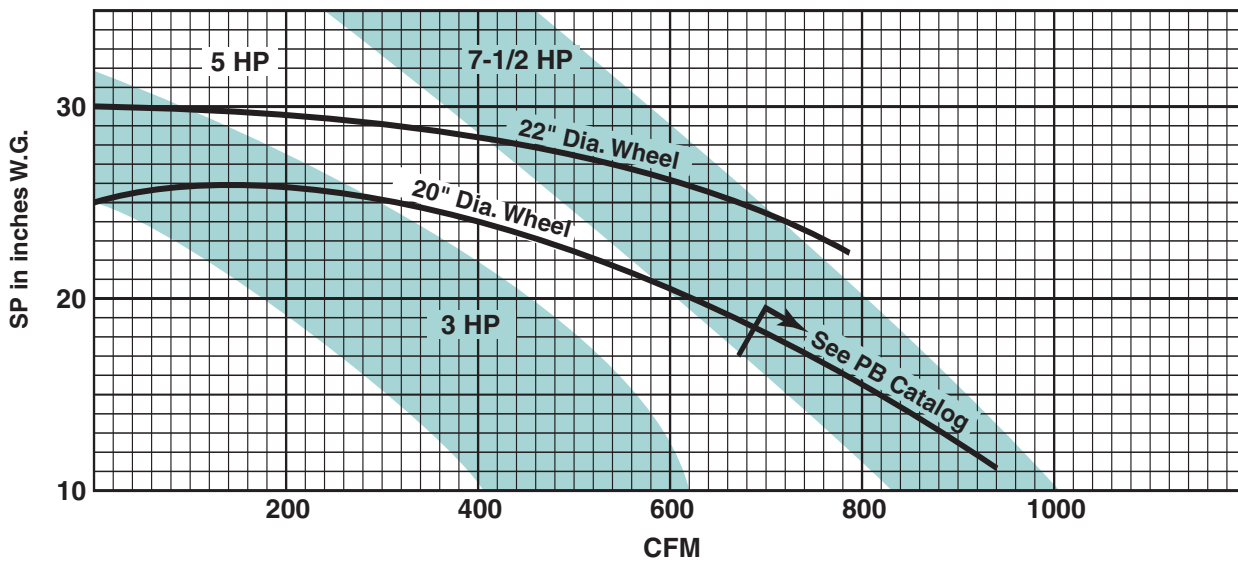

BELT DRIVE RATING TABLES

CFM and BHP at Static Pressure Shown • Ratings at 70°F., .075 Density, Sea Level

 **Model HPA** WHEEL DIA. 11.00" OUTLET AREA .063 SQ. FT. INLET AREA .120 SQ.FT.

CFM	1" SP		2" SP		3" SP		4" SP		5" SP		6" SP		7" SP		8" SP	
	RPM	BHP	RPM	BHP	RPM	BHP	RPM	BHP	RPM	BHP	RPM	BHP	RPM	BHP	RPM	BHP
100			2039	.14	2293	.15	2628	.20	2928	.26	3200	.33	3449	.41	3682	.49
150					2390	.21	2709	.29	2995	.37	3255	.45	3500	.52	3728	.60
200	1922	.15	2251	.22	2557	.29	2845	.37	3105	.46	3346	.55	3586	.67		
250	2202	.25	2526	.34	2784	.43	3035	.51	3266	.59	3500	.70				
300	2485	.38	2815	.49	3059	.60	3275	.70								
350	2777	.55	3094	.68												

 **Model HPB** WHEEL DIA. 14.00" OUTLET AREA .063 SQ. FT. INLET AREA .120 SQ.FT.

CFM	1" SP		2" SP		3" SP		4" SP		5" SP		6" SP		7" SP		8" SP		9" SP		10" SP	
	RPM	BHP	RPM	BHP	RPM	BHP	RPM	BHP	RPM	BHP	RPM	BHP	RPM	BHP	RPM	BHP	RPM	BHP	RPM	BHP
100			1582	.13	1775	.13	2038	.19	2270	.25	2480	.31	2673	.38	2852	.45	3020	.52	3180	.60
150			1741	.19	1863	.19	2106	.25	2324	.32	2522	.39	2709	.46	2889	.54	3057	.63	3217	.72
200	1461	.13	1984	.26	1984	.26	2210	.33	2419	.42	2609	.50	2789	.59	2957	.67	3116	.76	3266	.85
250	1674	.21	1933	.28	2152	.36	2350	.44	2536	.53	2718	.63	2892	.73	3054	.83	3206	.94	3352	1.05
300	1893	.31	2138	.41	2343	.50	2527	.59	2693	.68	2858	.79	3013	.89	3164	1.00	3315	1.12	3459	1.25
350	2120	.46	2352	.57	2545	.68	2720	.78	2881	.89	3030	1.00	3169	1.10	3312	1.23	3447	1.35		
400	2353	.64	2569	.78	2758	.90	2922	1.02	3075	1.14	3219	1.27	3355	1.39						
450	2591	.87	2793	1.03	2972	1.17	3134	1.31												
500	2833	1.16	3022	1.33	3192	1.49														
550	2879	1.30																		

CFM	11" SP		12" SP		13" SP	
	RPM	BHP	RPM	BHP	RPM	BHP
100	3331	.68	3476	.76	3615	.85
150	3369	.81	3514	.91	3653	1.00
200	3409	.95	3549	1.05	3688	1.15
250	3495	1.15	3631	1.26	3761	1.37
300	3596	1.37	3727	1.50	3853	1.63

 **Model HPC** WHEEL DIA. 17.00" OUTLET AREA .063 SQ. FT. INLET AREA .120 SQ.FT.

CFM	1" SP		2" SP		3" SP		4" SP		5" SP		6" SP		7" SP		8" SP		9" SP		10" SP	
	RPM	BHP	RPM	BHP	RPM	BHP	RPM	BHP	RPM	BHP	RPM	BHP	RPM	BHP	RPM	BHP	RPM	BHP	RPM	BHP
100					1440	.13	1661	.18	1855	.24	2031	.31	2192	.38	2343	.45	2484	.53	2618	.61
200			1270	.14	1501	.20	1697	.27	1871	.34	2047	.43	2208	.51	2359	.61	2499	.70	2633	.80
300	1237	.18	1459	.26	1643	.33	1823	.43	1987	.52	2144	.61	2287	.71	2421	.80	2545	.90	2661	1.01
400	1508	.36	1690	.45	1855	.55	2011	.66	2147	.75	2285	.87	2416	.99	2539	1.12	2663	1.25	2782	1.37
500	1797	.63	1949	.75	2095	.87	2228	.99	2360	1.12	2485	1.26	2597	1.38	2703	1.49	2814	1.64	2923	1.80
600	2095	1.02	2231	1.17	2353	1.31	2474	1.46	2591	1.60	2699	1.74	2811	1.91	2917	2.07	3016	2.22	3109	2.36
700	2399	1.56	2522	1.74	2633	1.91	2737	2.07	2837	2.24	2945	2.41	3041	2.58	3133	2.74	3229	2.93		
800	2708	2.27	2818	2.47	2920	2.67	3017	2.86												

CFM	11" SP		12" SP		13" SP		14" SP		15" SP		16" SP		17" SP		18" SP		19" SP	
	RPM	BHP	RPM	BHP	RPM	BHP	RPM	BHP	RPM	BHP	RPM	BHP	RPM	BHP	RPM	BHP	RPM	BHP
100	2745	.70	2866	.78	2983	.87	3095	.97	3203	1.07	3308	1.17	3409	1.27	3507	1.37	3603	1.48
200	2760	.90	2881	1.00	2998	1.11	3110	1.22	3218	1.33	3322	1.45	3424	1.57	3522	1.69	3618	1.81
300	2776	1.12	2897	1.25	3013	1.37	3126	1.50	3234	1.63	3338	1.77	3439	1.90	3538	2.04	3633	2.18
400	2895	1.50	3003	1.62	3107	1.75	3207	1.87	3303	2.00	3394	2.14	3481	2.28	3566	2.42	3649	2.57
500	3027	1.95	3126	2.11	3224	2.27	3324	2.43	3419	2.58	3512	2.74	3602	2.89				
600	3199	2.51	3287	2.65	3382	2.84												

Performance shown is for fans with inlet and outlet ducts.
BHP does not include drive losses

BELT DRIVE RATING TABLES

CFM and BHP at Static Pressure Shown • Ratings at 70°F., .075 Density, Sea Level



Model HPD

WHEEL DIA.
18.50"

OUTLET AREA
.063 SQ. FT.

INLET AREA
.120 SQ.FT.

CFM	4" SP		5" SP		6" SP		7" SP		8" SP		9" SP		10" SP		11" SP		12" SP		13" SP	
	RPM	BHP	RPM	BHP	RPM	BHP	RPM	BHP	RPM	BHP	RPM	BHP	RPM	BHP	RPM	BHP	RPM	BHP	RPM	BHP
100	1501	.16	1676	.22	1835	.28	1980	.34	2115	.41	2242	.48	2363	.55	2477	.63	2586	.71	2691	.78
200	1531	.26	1702	.33	1859	.40	2003	.48	2139	.56	2265	.64	2385	.73	2498	.82	2607	.91	2711	1.00
300	1645	.40	1789	.49	1926	.58	2057	.67	2181	.77	2297	.86	2412	.96	2525	1.07	2634	1.19	2738	1.30
400	1804	.61	1935	.72	2063	.83	2181	.95	2291	1.06	2398	1.18	2502	1.30	2600	1.42	2700	1.54	2795	1.67
500	1986	.90	2112	1.04	2227	1.17	2333	1.29	2439	1.42	2542	1.57	2640	1.71	2732	1.85	2820	2.00	2905	2.14
600	2189	1.29	2299	1.44	2409	1.59	2514	1.76	2613	1.92	2705	2.07	2793	2.21	2880	2.37	2969	2.54	3053	2.71
700	2451	1.90	2513	1.98	2604	2.14	2701	2.32	2795	2.50	2886	2.69	2974	2.88	3058	3.07	3137	3.24	3213	3.41
800	2759	2.81	2793	2.83	2828	2.85	2909	3.04	2989	3.22	3075	3.43	3158	3.63	3238	3.85	3318	4.07	3394	4.29

CFM	14" SP		15" SP		16" SP		17" SP		18" SP		19" SP		20" SP		21" SP		22" SP		23" SP	
	RPM	BHP	RPM	BHP	RPM	BHP	RPM	BHP	RPM	BHP	RPM	BHP	RPM	BHP	RPM	BHP	RPM	BHP	RPM	BHP
100	2792	.87	2889	.96	2983	1.05	3075	1.14	3163	1.24	3249	1.33	3333	1.43	3415	1.53	3495	1.64	3573	1.74
200	2812	1.09	2909	1.19	3003	1.30	3095	1.41	3183	1.52	3269	1.63	3353	1.74	3435	1.86	3515	1.98	3593	2.10
300	2839	1.42	2935	1.38	3029	1.65	3120	1.77	3208	1.89	3294	2.02	3377	2.14	3459	2.27	3538	2.40	3616	2.53
400	2888	1.79	2977	1.92	3063	2.04	3147	2.17	3235	2.32	3321	2.46	3404	2.61	3485	2.76	3565	2.91	3643	3.06
500	2993	2.29	3076	2.44	3157	2.59	3236	2.74	3316	2.90	3394	3.05	3471	3.21	3546	3.36	3619	3.52	3690	3.68
600	3136	2.89	3215	3.06	3290	3.23	3364	3.41	3436	3.58	3508	3.76	3580	3.93	3650	4.11	3719	4.29	3786	4.47
700	3287	3.58	3336	3.77	3439	3.97	3513	4.17	3585	4.37	3654	4.57	3723	4.78	3789	4.98				
800	3469	4.51	3539	4.71	3607	4.91														



Model HPE

WHEEL DIA.
22.00"

OUTLET AREA
.063 SQ. FT.

INLET AREA
.120 SQ.FT.

CFM	4" SP		5" SP		6" SP		7" SP		8" SP		9" SP		10" SP		11" SP		12" SP		13" SP	
	RPM	BHP	RPM	BHP	RPM	BHP	RPM	BHP	RPM	BHP	RPM	BHP	RPM	BHP	RPM	BHP	RPM	BHP	RPM	BHP
100	1262	.20	1405	.26	1537	.33	1660	.41	1775	.49	1883	.57	1985	.66	2083	.75	2176	.84	2265	.94
200	1331	.33	1462	.41	1588	.50	1707	.60	1817	.70	1921	.80	2019	.91	2112	1.01	2201	1.13	2287	1.24
300	1463	.53	1582	.64	1695	.75	1802	.86	1903	.98	1997	1.10	2087	1.22	2172	1.35	2256	1.48	2341	1.62
400	1623	.82	1738	.96	1843	1.10	1941	1.24	2033	1.38	2119	1.52	2203	1.67	2288	1.82	2368	1.98	2446	2.13
500	1799	1.20	1904	1.38	2005	1.55	2099	1.73	2188	1.90	2273	2.08	2353	2.25	2431	2.43	2505	2.61	2576	2.78
600	1989	1.72	2088	1.92	2181	2.13	2268	2.34	2353	2.54	2435	2.76	2513	2.97	2588	3.18	2660	3.39	2730	3.60
700	2191	2.40	2282	2.62	2369	2.85	2452	3.10	2532	3.34	2608	3.58	2680	3.82	2753	4.07	2823	4.31	2891	4.56
800	2399	3.26	2485	3.52	2566	3.78	2644	4.04	2719	4.31	2792	4.58	2863	4.86	2930	5.14	2996	5.41	3059	5.69
900	2614	4.32	2694	4.62	2771	4.91	2845	5.21	2916	5.50	2984	5.79	3051	6.09	3116	6.41	3180	6.72	3242	7.03
1000	2835	5.60	2909	5.94	2981	6.28	3051	6.61	3119	6.94	3184	7.26	3247	7.58	3309	7.90	3369	8.24	3429	8.59
1100	3059	7.14	3130	7.52	3197	7.89	3262	8.26	3327	8.62	3389	8.99	3450	9.35	3509	9.70				
1200	3289	8.97	3353	9.37	3417	9.78														

CFM	14" SP		15" SP		16" SP		17" SP		18" SP		19" SP		20" SP		21" SP		22" SP		23" SP	
	RPM	BHP	RPM	BHP	RPM	BHP	RPM	BHP	RPM	BHP	RPM	BHP	RPM	BHP	RPM	BHP	RPM	BHP	RPM	BHP
100	2350	1.04	2433	1.14	2513	1.24	2591	1.35	2666	1.46	2739	1.57	2810	1.69	2880	1.81	2948	1.93	3014	2.05
200	2369	1.36	2448	1.48	2525	1.60	2599	1.72	2671	1.85	2742	1.97	2810	2.10	2877	2.24	2942	2.37	3008	2.51
300	2423	1.76	2503	1.90	2579	2.05	2654	2.20	2726	2.35	2796	2.50	2864	2.66	2931	2.82	2996	2.98	3060	3.14
400	2521	2.29	2593	2.45	2663	2.61	2731	2.77	2797	2.94	2861	3.10	2924	3.27	2986	3.44	3051	3.62	3115	3.81
500	2645	2.96	2711	3.14	2780	3.33	2847	3.52	2913	3.72	2976	3.91	3038	4.11	3099	4.30	3158	4.50	3216	4.70
600	2798	3.81	2863	4.02	2927	4.23	2989	4.45	3049	4.66	3107	4.87	3165	5.09	3221	5.30	3276	5.52	3334	5.75
700	2957	4.81	3021	5.05	3083	5.30	3144	5.55	3203	5.79	3261	6.04	3317	6.29	3373	6.53	3427	6.78	3479	7.03
800	3123	5.97	3185	6.25	3246	6.53	3306	6.81	3364	7.10	3420	7.38	3475	7.66	3529	7.94	3582	8.22	3634	8.51
900	3301	7.34	3360	7.65	3417	7.96	3472	8.27	3529	8.59	3584	8.91	3639	9.22	3692	9.54	3744	9.86		
1000	3487	8.93	3544	9.28	3599	9.62	3653	9.97												

CFM	24" SP		25" SP		26" SP		27" SP		28" SP		29" SP	
	RPM	BHP	RPM	BHP	RPM	BHP	RPM	BHP	RPM	BHP	RPM	BHP
100	3079	2.17	3143	2.30	3205	2.43	3266	2.56	3326	2.70	3386	2.83
200	3073	2.66	3137	2.80	3199	2.95	3260	3.10	3320	3.26	3379	3.41
300	3122	3.30	3183	3.46	3243	3.63	3302	3.80	3359	3.97	3416	4.14
400	3177	4.00	3238	4.19	3298	4.38	3356	4.58	3414	4.77	3470	4.97
500	3273	4.90	3329	5.10	3383	5.30	3437	5.51	3490	5.71	3541	5.92
600	3390	5.98	3445	6.21	3499	6.44	3553	6.67	3605	6.91	3656	7.14
700	3531	7.27	3582	7.52	3632	7.77	3681	8.02	3730	8.27	3777	8.52
800	3686	8.79	3736	9.07	3785	9.35	3834	9.63	3881	9.91		

Performance shown is for fans with inlet and outlet ducts.

BHP does not include drive losses



DIMENSIONS and SPECIFICATIONS

Arrangement #4, Direct Drive

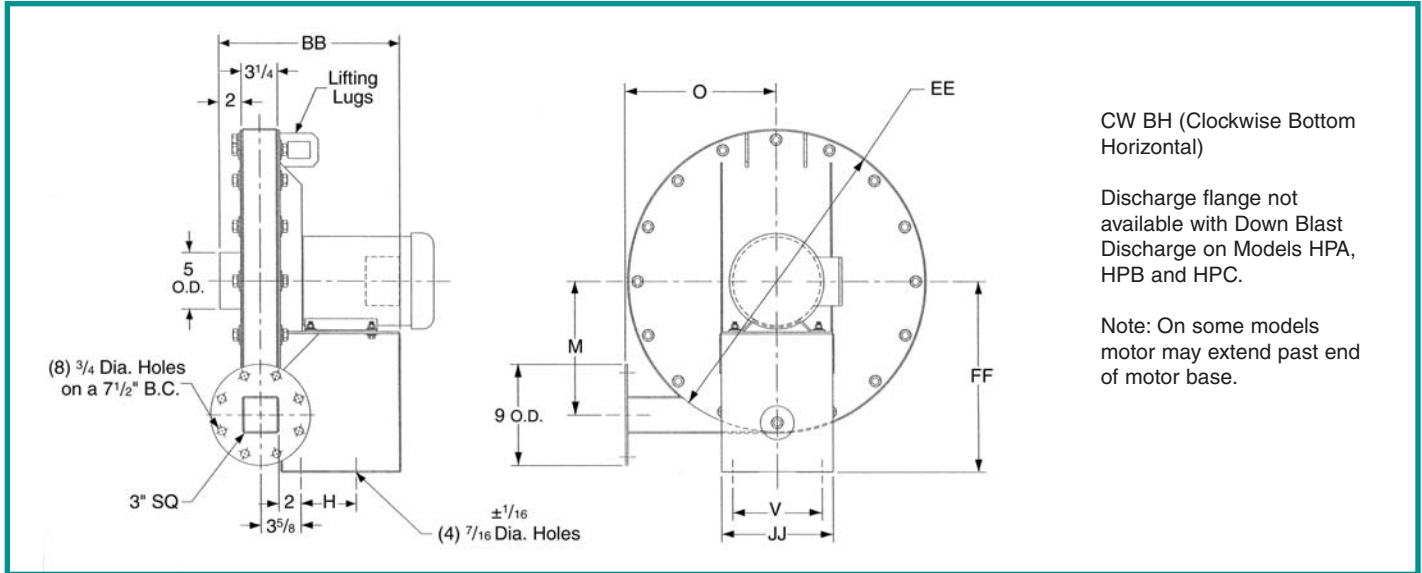

DIMENSIONS IN INCHES ±1/8"

MODEL	MOTOR FRAME	G	H	J	M	O	V	BB	EE	FF	JJ	SHIP WT. LESS MTR.
HPA	56-143T	3 5/8	5	2	5 7/8	8 1/8	5 1/2	14 1/4	15	11	7 1/2	60
HPB	56-145T	3 5/8	5	2	7 3/8	9 5/8	5 1/2	14 1/4	18	12 1/2	7 1/2	70
HPC	56-145T	3 5/8	5	2	8 7/8	11 1/8	7 1/2	14 1/4	21	14	9 1/2	90
	182T-184T							16 1/4				93
HPD	56-184T	3 5/8	5	2	9 7/8	11 5/8	7 1/2	16 1/4	23	15	9 1/2	123
HPE	56-184T	3 5/8	5	2	11 7/8	13 5/8	8	16 1/4	27	17	10	140
	213T-215T		9	2			9				18 1/16	11

★ NOTE

Discharge flange not available with down-blast discharge on models HPA, HPB and HPC.

INLET FLANGE DIMENSIONS FOR ALL HP's

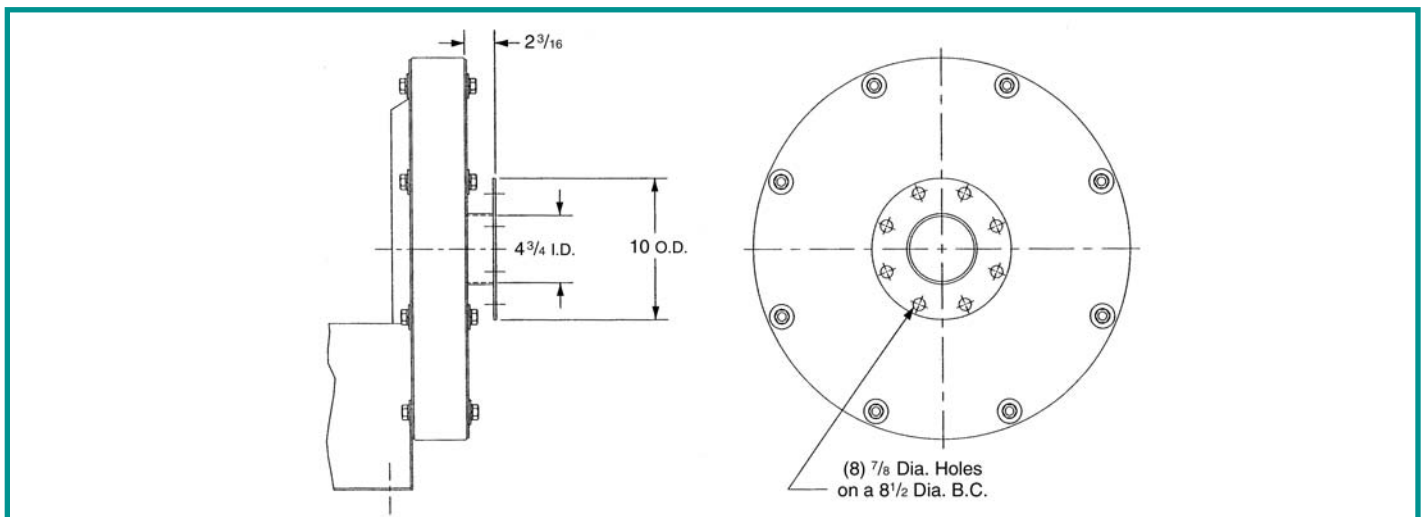

⚠ DANGER

All fans & blowers shown have rotating parts and pinch points. Severe personal injury can result if operated without guards. Stay away from rotating equipment unless it is disconnected from its power source. Read operating instructions.

HP MATERIAL GAUGES

HOUSING	10
INLET SIDE PLATE	10
DRIVE SIDE PLATE	7
BASE	10
FLANGES	10



DIMENSIONS and SPECIFICATIONS

Arrangement #1 and #9, Belt Drive (specify 9R or 9L)

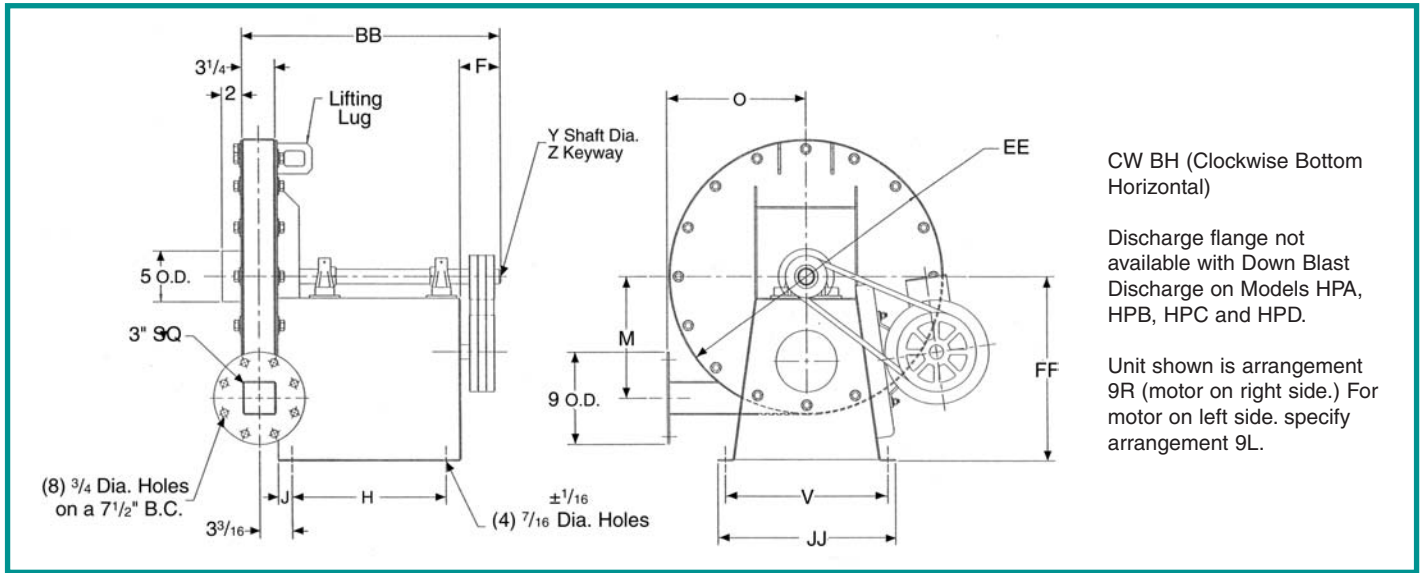

CW BH (Clockwise Bottom Horizontal)

Discharge flange not available with Down Blast Discharge on Models HPA, HPB, HPC and HPD.

Unit shown is arrangement 9R (motor on right side.) For motor on left side, specify arrangement 9L.

DIMENSIONS IN INCHES ±1/8"

MODEL	MOTOR FRAME	F	G	H	J	M	O	V	Y	Z	BB	EE	FF	JJ	SHIP WT. LESS MTR.
HPA	56-145T	3	3 3/16	11	1 1/8	5 7/8	8 1/8	12 5/16	1	1/4	22 5/16	15	14	13 13/16	105
HPB	56-145T	3	3 3/16	11	1 1/8	7 7/8	9 5/8	12 5/16	1	1/4	22 5/16	18	14	13 13/16	115
HPC	56-184T	3	3 3/16	11	1 1/8	8 7/8	11 1/8	12 5/16	1	1/4	22 5/16	21	14	13 13/16	135
HPD	56-215T	4	3 3/16	15	1 1/8	9 7/8	11 1/8	16	1 1/16	3/8	27 5/16	23	18	17 1/2	160
HPE	56-215T	4	3 3/16	15	1 1/8	11 7/8	13 5/8	16	1 1/16	3/8	27 5/16	27	18	17 1/2	170

CENTER DISTANCE

MODEL	MOTOR FRAME SIZE							
	56		143T-145T		182T-184T		213T-215T	
	MIN.	MAX.	MIN.	MAX.	MIN.	MAX.	MIN.	MAX.
HPA	9 7/16	11 7/16	9 5/8	11 5/8				
HPB	9 7/16	11 7/16	9 5/8	11 5/8				
HPC	9 7/16	11 7/16	9 5/8	11 5/8	10	11 3/4		
HPD	11 7/16	13 7/16	11 7/16	13 3/8	13 3/16	15 1/8	13 3/16	16
HPE	11 7/16	13 7/16	11 7/16	13 3/8	13 3/16	15 1/8	13 13/16	16

★ NOTE

Discharge flange not available with down-blast discharge on models HPA, HPB, HPC and HPD.

8 DISCHARGE POSITIONS AVAILABLE

Discharges shown are determined by viewing fan from motor or drive side.



CW-TH
Clockwise Top Horizontal Discharge



CW-DB
Clockwise Down-Blast Discharge



CW-BH
Clockwise Bottom Horizontal Discharge



CW-UB
Clockwise Up-Blast Discharge



CCW-TH
Counter-Clockwise Top Horizontal Discharge



CCW-DB
Counter-Clockwise Down-Blast Discharge



CCW-BH
Counter-Clockwise Bottom Horizontal Discharge



CCW-UB
Counter-Clockwise Up-Blast Discharge