

**cincinnati fan**

**OEM and Industrial Air Handling Specialist**



# **HDBI BLOWERS**

**BACKWARD  
INCLINED**

**CLASS II  
CLASS III  
CLASS IV**

**7697 Snider Road, Mason, OH 45040-9135**

**Telephone: 513-573-0600**

Visit us at [www.cincinnati-fan.com](http://www.cincinnati-fan.com) for more information.

**Cat. No. HDBI-0711**  
Supersedes HDBI-1006



# Cincinnati Fan

## A Company That Stands Behind Its Product

Since the founding of **Cincinnati Fan** in 1956, the company's mission has been to provide quality products at competitive prices, backed by dependable service.

This mission is carried out by specializing in the market for industrial air handling products up to 125 HP. But specialization does not mean the product line is small. **Cincinnati Fan** offers a wide variety of standard and customized products, production flexibility, and customer responsiveness.

**Cincinnati Fan** has over 170 experienced sales engineers across the U.S. and Canada ready to serve your air handling needs.

Visit us at [www.cincinnati-fan.com](http://www.cincinnati-fan.com) for more information.

**Cincinnati Fan** can provide:

- Technical evaluation for correct performance conditions.
- Review of air stream and ambient conditions that require special attention.
- Selection of proper components to meet required design specifications.
- Selection of proper accessories.
- System analysis for proper fan design.

**Cincinnati Fan** operates in a modern facility specifically designed for world class manufacturing enabling us to build standard products to order, including accessories, and ship within 10 to 15 working days.

With support like this, you can be sure your **Cincinnati Fan** product will be well-built and will provide maximum dependability and longevity.

## HDBI FEATURES

- A) Backward inclined blades are fabricated of heavy-gauge, high-strength steel to assure long lasting, efficient operation.
- B) Turned, ground and polished shafting assures smooth operation. A rust preventive coating is applied prior to shipment.
- C) Heavy-duty, self-aligning, relubricatable, ball bearings in cast-iron pillow blocks. Bearings are selected for optimal performance depending on fan size and class.
- D) Bearing base is heavy steel construction with internal supports to maximize rigidity and assure long equipment life. Arrangement #1 fans can be converted to arrangement #9 with the addition of the motor slide base.
- E) Inlet side support is used to assure a vibration-free, stable housing.
- F) Slip collar inlet (not shown) is used for duct work connection. Flanged inlet optional.
- G) Inlet bell is designed for smooth air entrance into the wheel inlet for maximum efficiency.
- H) Reversible housing provides increased configuration flexibility. Removable side plates allow the wheel to be removed from the motor or inlet side of the housing. Housings are rotatable in 45 degree increments. Wheels are not reversible. See note at right.

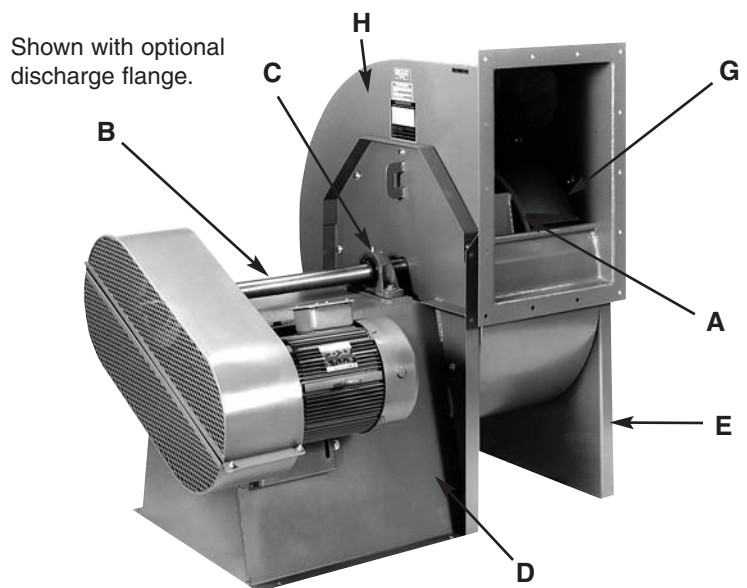

**NOTE: HDBI-330 and HDBI-360 housings are not rotatable or reversible.**

## ADVANTAGES OF DIRECT DRIVE ARRANGEMENT #4 & #4HM

All sizes available with 2 wheel diameters in 100% to 50% widths in 5% increments



Shown with optional inlet and discharge flanges.

### ADVANTAGES

- Compact - requires less space.
- Weighs Less - requires less supporting structure.
- Less Maintenance - no belts or fan bearings to replace.
- Less Expensive - above features result in lower first cost and lower maintenance cost.
- More Ratings - the combination of several motor speeds, two wheel diameters and eleven fan widths results in a vast selection of direct drive ratings.
- Temperature - good up to 200°F. (93°C.)



Shown with optional inlet and discharge flanges.

### OPTIONAL ARRANGEMENT 4HM HORIZONTAL MOUNTING

Ideal for bag house or other equipment requiring the simplicity of a horizontally mounted fan. Motors are limited to frame 365T maximum.

This mounting is available on all sizes. All horizontal mount housings are non-reversible. Inlet flange is optional and must be added if required. Supporting equipment must be adequate to support weights shown on page 26 plus motor weight.

## SIX STANDARD ARRANGEMENTS

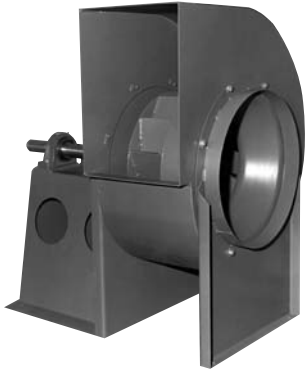

### ARRANGEMENT 1 (V-BELT DRIVE)

- Motor not mounted on bearing base.
- Wheel mounted on fan shaft with two pillow block bearings.
- Maximum temperature of standard design: 300°F. (149°C.); high temperature designs up to 750°F. (398°C.)



*(Shown with optional discharge flange.)*

### ARRANGEMENT 4 (DIRECT DRIVE)

- Motor mounted on motor base.
- Wheel mounted on motor shaft.
- Maximum temperature of standard design: 200°F (93°C.); high temperature design not available.

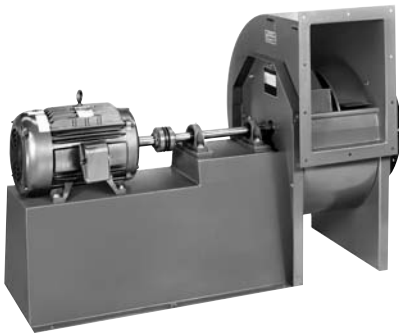

*(Shown with shaft/coupling guard removed and optional discharge flange.)*

### ARRANGEMENT 8 (DIRECT DRIVE)

- Motor mounted on motor base extending beyond the bearing base. Shaft/coupling guard is standard.
- Wheel mounted on fan shaft with two pillow block bearings.
- Maximum temperature of standard design: 300°F. (149°C.); high temperature designs up to 750°F. (398°C.)



*(Shown with optional discharge flange.)*

### ARRANGEMENT 9 (V-BELT DRIVE)

- Motor mounted on an adjustable slide base on the side of the bearing base.
- Wheel mounted on fan shaft with two pillow block bearings.
- Maximum temperature of standard design: 300°F. (149°C.); high temperature designs up to 750°F. (398°C.)

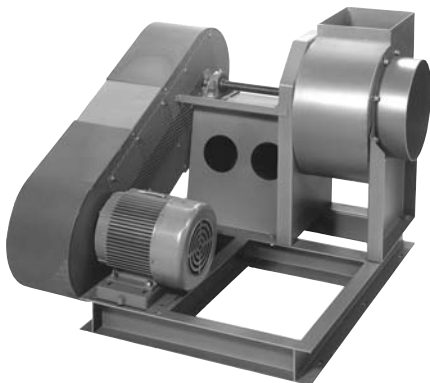

### ARRANGEMENT 9CB (V-BELT DRIVE)

- Same as Arrangement 9 except motor and fan are mounted on a common channel base.
- Maximum temperature of standard design: 300°F. (149°C.); high temperature designs up to 750°F. (398°C.)

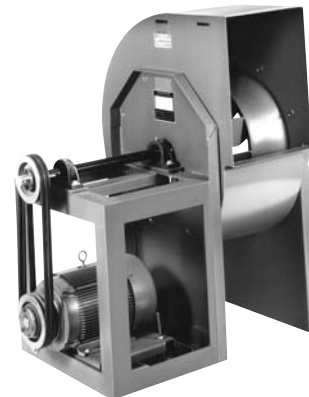

*(Shown with weather cover removed)*

### ARRANGEMENT 10 (V-BELT DRIVE)

- Motor mounted on adjustable base under the fan shaft.
- Wheel mounted on fan shaft with two pillow block bearings.
- Maximum temperature of standard design: 300°F. (149°C.); high temperature design not available.

## OPTIONAL ACCESSORIES



### Shaft Seal

Teflon shaft seal good to 400°F. (204°C.) Ceramic fiber gasket material with steel cover plate above 400°F. (205°C.)

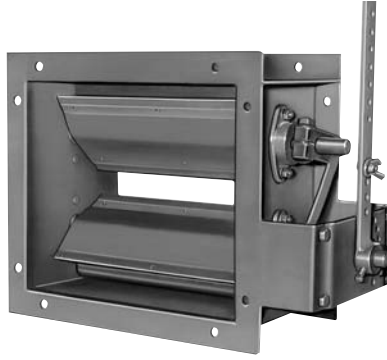

### Outlet Damper

All dampers are 1 or 2 blade. All dampers 10" deep flange to flange. Opposed blade construction is standard.



### Belt Guard

Belt guard standard on Arrangement 9 and 9CB only. **Painted safety yellow.**

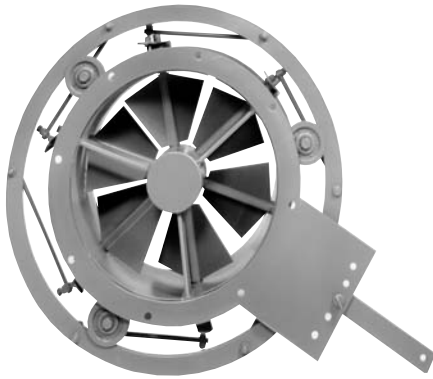

### Inlet Vane Control

Linkage assembly is external on smaller sizes, internal on larger sizes. Inlet vane depth varies with inlet diameter. Contact your local Cincinnati Fan sales representative for dimensions.

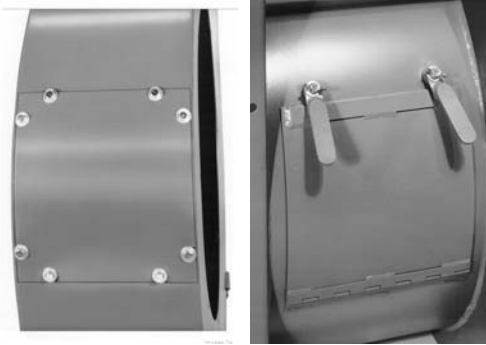

### Inspection Door

Bolted or quick-release doors positioned as specified on scroll. Rubber gasket standard up to 250°F. (121°C.) Ceramic fiber gasket standard at temperatures above 250°F (122°C.).



### Drain Connection

3/4" pipe coupling welded to lowest point of housing. Not required on BH discharge position.



### Shaft and/or Heat Slinger Guard

Guard available on Arrangement 1, 9 and 9CB. Covers bearings and shaft between fan housing and belt guard. Has extended lube lines. Standard on high temperature fans above 301°F. (150°C). **Painted safety yellow.**

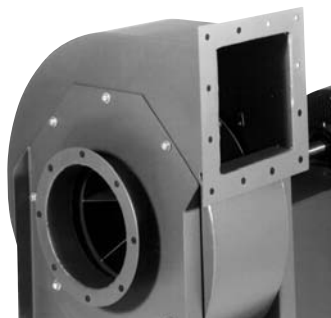

### Inlet & Outlet Flanges

Flanges on inlet and outlet available where installation requires tight duct connections. Standard hole pattern furnished. Outlet flange not available on some discharge positions. Outlet flange standard on all sizes 270 through 360. See page 31 for dimensions.

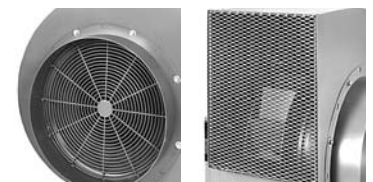

### Inlet & Outlet Guards

Ring guard on inlet and expanded metal on discharge. Meet OSHA approval.



## DANGER

All fans & blowers shown have rotating parts and pinch points. Severe personal injury can result if operated without guards. Stay away from rotating equipment unless it is disconnected from its power source.

Read operating instructions.

# SPARK-RESISTANT CONSTRUCTION

**Type A:** All parts in contact with airstream are of nonferrous material. (**Contact your local Cincinnati Fan sales representative**).

**Type B:** Fabricated aluminum wheel and aluminum rubbing ring on motor shaft or fan shaft. **Maximum Temperature 200°F. (93°C.) all arrangements.**

**Type C:** Consists of aluminum inlet bell and aluminum plate on drive side of the fan. Maximum Temperature is the same as for high temperature construction below for each arrangement.

Maximum RPM for Aluminum Wheels*	
Size	Max. RPM
120	5400
130	4999
150	4712
160	4285
180	3885
200	3574
220	3550
240	2837
270	2476
300	2300
330	2300
360	1950

\* Up to 200°F. (93°C.) Consult your local Cincinnati Fan sales representative for higher temperatures and/or higher RPMs.

## ⚠ WARNING

The use of aluminum or aluminum alloys in the presence of steel which has been allowed to rust requires special consideration. Research by the U.S. Bureau of Mines and others has shown that aluminum impellers rubbing on rusty steel may cause high intensity sparking.

The use of the above Standard in no way implies a guarantee of safety for any level of spark resistance. Spark-resistant construction also does not protect against ignition of explosive gases caused by catastrophic failure or from any airstream material that may be present in a system.

# HIGH TEMPERATURE CONSTRUCTION

**Standard Construction:** Arrangements 1, 8, 9, 9CB and 10 suitable to 300° F. (149° C.) Arrangements 4 and 4HM suitable to 200° F. (93° C.)

**201°- 400° F. (94° - 204° C.) Construction:** Standard fan with heat slinger, slinger guard, teflon shaft seal and extended hub on wheel. Arrangements 4 and 4HM only.

**301°- 400° F. (150° - 204° C.) Construction:** Standard fan with heat slinger, fan shaft and slinger guard and teflon shaft seal. Arrangements 1, 8, 9 and 9CB.

**401°- 600° F. (205° - 316° C.) Construction:** Standard fan with heat slinger, fan shaft and slinger guard, high temp shaft seal, gaskets and paint. Arrangements 1, 8, 9 and 9CB.

**601°- 750° F. (317° - 398° C.) Construction:** Standard fan with high temp bearings, heat slinger, fan shaft and slinger guard, high temp shaft seal, gaskets and paint. Arrangements 1, 8, 9 and 9CB

TEMPERATURE RANGE	MAXIMUM RPM REDUCTION FACTOR†
Up to 175°F.	0%
176°-200°	2%
201°-300°	4%
301°-400°	7%
401°-500°	11%
501°-600°	15%
601°-700°	20%
701°-750°	30%

† Steel wheels only.

## TEMPERATURE - ALTITUDE CONVERSIONS

AIR TEMP. °F	AIR TEMP. °C	ALTITUDE IN FEET ABOVE SEA LEVEL										
		0	1000	2000	3000	4000	5000	6000	7000	8000	9000	10000
0°	-18°	.87	.91	.94	.98	1.01	1.05	1.09	1.13	1.17	1.22	1.26
40°	4°	.94	.98	1.02	1.06	1.10	1.14	1.19	1.23	1.28	1.32	1.36
70°	21°	1.00	1.04	1.08	1.12	1.16	1.20	1.25	1.30	1.35	1.40	1.45
80°	27°	1.02	1.06	1.10	1.14	1.19	1.23	1.28	1.33	1.38	1.43	1.48
100°	38°	1.06	1.10	1.14	1.19	1.23	1.28	1.33	1.38	1.43	1.48	1.54
120°	49°	1.09	1.14	1.18	1.23	1.28	1.32	1.38	1.43	1.48	1.53	1.58
140°	60°	1.13	1.18	1.22	1.27	1.32	1.37	1.42	1.48	1.54	1.58	1.65
160°	71°	1.17	1.22	1.26	1.31	1.36	1.42	1.47	1.53	1.59	1.64	1.70
180°	82°	1.21	1.26	1.30	1.36	1.41	1.46	1.52	1.58	1.64	1.70	1.75
200°	93°	1.25	1.29	1.34	1.40	1.45	1.51	1.57	1.63	1.69	1.75	1.81
250°	121°	1.34	1.39	1.45	1.50	1.56	1.62	1.68	1.74	1.82	1.88	1.94
300°	149°	1.43	1.49	1.55	1.61	1.67	1.74	1.80	1.87	1.94	2.00	2.08
350°	177°	1.53	1.59	1.65	1.72	1.78	1.85	1.92	2.00	2.07	2.14	2.22
400°	205°	1.62	1.69	1.75	1.82	1.89	1.96	2.04	2.12	2.20	2.27	2.35
450°	232°	1.72	1.79	1.86	1.93	2.00	2.08	2.16	2.24	2.33	2.41	2.50
500°	260°	1.81	1.88	1.96	2.03	2.11	2.19	2.28	2.36	2.46	2.54	2.62
550°	288°	1.91	1.98	2.06	2.14	2.22	2.30	2.40	2.49	2.58	2.68	2.77
600°	315°	2.00	2.08	2.16	2.24	2.33	2.42	2.50	2.61	2.71	2.80	2.90
650°	343°	2.10	2.18	2.26	2.35	2.44	2.54	2.63	2.74	2.84	2.94	3.04
700°	371°	2.19	2.27	2.36	2.46	2.55	2.65	2.75	2.86	2.97	3.06	3.18
750°	398°	2.28	2.37	2.47	2.56	2.66	2.76	2.87	2.98	3.10	3.19	3.31

Fan performance tables are developed using standard air which is 70°F., 29.92" barometric pressure and .075 lbs. per cubic foot. Density changes resulting from temperature or barometric pressure variations (such as higher altitudes) must be corrected to standard conditions before selecting a fan based on standard performance data.

Temperature and/or altitude conversion factors are used in making corrections to standard conditions.

### EXAMPLE:

Select a belt driven HDBI-300 to deliver 8327 CFM at .50" SP at 200°F. (93°C.), and 7000' altitude.

**STEP 1.** From the table, conversion factor is 1.63.

**STEP 2.** Correct static pressure is: 1.63 x .50" SP = .81" SP at standard conditions.

**STEP 3.** Check HDBI catalog for 8327 CFM at .81" SP. We select a belt driven HDBI-300 and interpolation gives 660 RPM and 1.83 BHP.

**STEP 4.** Correct the BHP for the lighter air: 1.83 ÷ 1.63 = 1.12 BHP. A 1.5 HP motor will suffice at 200°F., and 7000' but not at standard conditions. Special motor insulation may be required due to altitude.

# DIRECT DRIVE RATING TABLES

CFM and BHP at Static Pressure Shown • Ratings at 70°F., .075 Density, Sea Level

MODEL	RPM	0" SP		1" SP		2" SP		3" SP		4" SP		5" SP	
		CFM	BHP	CFM	BHP	CFM	BHP	CFM	BHP	CFM	BHP	CFM	BHP
HDBI-120	1150	1170 †	.09	1375 † 3370 †	.39 2.82	3180 †	2.98	2975	3.08	2750	3.15	2490	3.16
	1750	1780 †	.32										
	3500	3560 †	2.54										
HDBI-130	1150	1540 †	.16	1828 † 4457	.62 4.68	1086 †	.59 4.86	3946	4.93	3656	4.99	3353	5.01
	1750	2344 †	.56										
	3500	4688	4.50										
HDBI-150	1150	2100 †	.23	1175 † 2700 † 6155	.28 .96 6.96	2070 †	1.00 7.28	5690	7.57	5405	7.71	5115	7.83
	1750	3195 †	.82										
	3500	6385	6.59										
HDBI-160	1150	2795 †	.38	1875 † 3730 8250	.46 1.53 11.12	3080	1.61 11.55	2170	1.55 11.98	7460	12.26	7140	12.44
	1750	4250 †	1.33										
	3500	8500	10.62										
HDBI-180	1150	3780 †	.69	2800 † 5195 11225	.82 2.68 18.28	4495	2.83 18.86	3685	2.87 19.44	10395	20.02	10055	20.32
	1750	5750	2.40										
	3500	11500	17.58										
HDBI-200	1150	4975 †	.99	3935 † 6960 14830	1.17 3.88 28.74	2140 †	1.10 4.09 29.50	5435	4.23 30.27	4390	4.14 31.03	13620	31.80
	1750	7570	3.47										
	3500	15140	27.79										
HDBI-220	1150	6915	1.65	5955	1.99 6.41	4720	2.11 6.89	8610	7.26	7755	7.39	6820	7.42
	1750	10520	5.80										
HDBI-240	1150	9230	2.67	8185	3.15 10.22	6945	3.39 10.92	4880	3.26 11.44	11185	11.85	10205	11.97
	1750	14045	9.39										
HDBI-270	1150	12885	4.68	11780	5.34 17.62	10550	5.79 18.53	9010	5.93 19.37	16575	20.00	15745	20.63
	1750	19605	16.49										
HDBI-300	1150	17670	7.92	16450	8.85 29.54	15130	9.54 30.79	13630	9.98 32.04	11525	9.89 33.06	22680	33.92
	1750	26890	27.92										
HDBI-330	1150	23521	12.76	22173	13.95 46.77	20784	15.04 48.58	19242	15.79 50.38	17420	16.13 52.19	14835	15.81 53.42
	1750	35793	44.97										
HDBI-360	1150	30536	19.72	29067	21.26 71.82	27597	22.80 74.16	25940	23.84 76.51	24238	24.79 78.85	22104	24.96 81.13
	1750	46469	69.47										

MODEL	RPM	6" SP		7" SP		8" SP		9" SP		10" SP		11" SP	
		CFM	BHP	CFM	BHP	CFM	BHP	CFM	BHP	CFM	BHP	CFM	BHP
HDBI-120	3500	2170	3.09	1580	2.76								
HDBI-130	3500	2996	4.96	2595	4.85	2172	4.71						
HDBI-150	3500	4810	7.94	4510	8.06	4140	8.02	3700	7.87	3200	7.66		
HDBI-160	3500	6820	12.61	6490	12.76	6160	12.90	5825	13.04	5360	12.86	4870	12.64
HDBI-180	3500	9705	20.56	9350	20.80	8990	21.01	8620	21.20	8255	21.40	7885	21.59
HDBI-200	3500	13240	32.13	12850	32.44	12465	32.75	12075	33.04	11675	33.30	11270	33.56
HDBI-240	1750	9175	12.02										
HDBI-270	1750	14730	20.81	13625	20.87	11950	20.29						
HDBI-300	1750	21760	34.77	20685	35.19	19515	35.34	18025	35.05				
HDBI-330	1750	30240	54.56	29226	55.71	28133	56.57	26846	56.77	25560	56.98	23764	56.34
HDBI-360	1150	19092	24.39	39416	84.10	38309	85.58	37203	87.06	35851	87.53	34448	87.80
	1750	40522	82.61										

MODEL	RPM	12" SP		13" SP		14" SP		15" SP		16" SP		17" SP	
		CFM	BHP	CFM	BHP	CFM	BHP	CFM	BHP	CFM	BHP	CFM	BHP
HDBI-160	3500	4335	12.39										
HDBI-180	3500	7375	21.34	6865	21.08	6265	20.74						
HDBI-200	3500	10870	33.83	10465	34.09	9935	33.87	9375	33.54	8775	33.15	8130	32.70
HDBI-330	1750	21713	55.28										
HDBI-360	1750	33046	88.06	31056	87.17	28817	85.80						

Performance certified is for installation type B-Free inlet, Ducted Outlet.  
Performance ratings do not include the effects of appurtenances (accessories).

† See pages 25 or 26 for minimum motor frame sizes regardless of BHP.



Cincinnati Fan & Ventilator Company certifies that the HDBI Heavy Duty Backward Inclined Fans shown on this page and on pages 12 through 23 are licensed to bear the AMCA seal. The ratings shown are based on tests and procedures performed in accordance with AMCA Publication 211 and comply with the requirements of the AMCA Certified Ratings Program.

Fans are capable of operating to the maximum safe speeds shown on each performance table. These speeds permit obtaining the minimum SP/OV limits established as follows:

- CLASS II - 8.5" SP at 3000 FPM to 4.25" SP at 4175 FPM.
- CLASS III - 13.5" SP at 3780 FPM to 6.75" SP at 5260 FPM.
- CLASS IV - 20" SP at 4600 FPM to 10" SP at 6400 FPM.

# DIRECT DRIVE RATING TABLES

## for partial width fans with two wheel types

The partial width fan ratings shown on this page and on Pages 9,10 and 11 were derived from tests performed in accordance with AMCA Publication 211 and fan laws were applied to arrive at the data shown for partial width fans.

However, none of the partial width fans or fans with SQBI wheels are licensed to bear the AMCA seal.

All 100% width fans with HDBI wheels are licensed to bear the AMCA seal as shown on pages 7 and 12 through 23.

MODEL NUMBER	RPM	WHEEL TYPE	FAN WIDTH	1" SP		2" SP		3" SP		4" SP		5" SP		6" SP	
				CFM	BHP	CFM	BHP	CFM	BHP	CFM	BHP	CFM	BHP	CFM	BHP
HDBI-120	1750	SQBI	1/2	813 †	.26	600 †	.26								
	1750	SQBI	3/4	1220 †	.39	900 †	.40								
	1750	HDBI	FULL	1375 †	.39										
	1750	SQBI	FULL	1627 †	.52	1201 †	.53								
	3500	HDBI	1/2	1685 †	1.41	1590 †	1.49	1488 †	1.54	1375 †	1.58	1245 †	1.58	1085 †	1.55
	3500	SQBI	1/2	1858 †	1.87	1789 †	1.96	1712 †	2.03	1627 †	2.08	1539 †	2.13	1437 †	2.14
	3500	HDBI	3/4	2527 †	2.10	2385 †	2.20	2231 †	2.30	2063 †	2.36	1868 †	2.37	1628 †	2.30
	3500	SQBI	3/4	2788 †	2.80	2683 †	2.93	2568	3.04	2441	3.12	2309	3.19	2155	3.21
	3500	HDBI	FULL	3370 †	2.82	3180 †	2.98	2975	3.08	2750	3.15	2490	3.16	2170	3.09
	3500	SQBI	FULL	3717	3.73	3578	3.91	3424	4.05	3255	4.16	3079	4.26	2874	4.28
HDBI-130	1750	SQBI	1/2	1127 †	.41	919 †	.44	799 †	.46						
	1750	SQBI	3/4	1690 †	.62	1378 †	.65	1199 †	.70						
	1750	HDBI	FULL	1828 †	.62	1086 †	.59								
	1750	SQBI	FULL	2254 †	.83	1838 †	.87	1599 †	.93						
	3500	HDBI	1/2	2278 †	2.27	2175 †	2.39	2065	2.46	1953 †	2.53	1820 †	2.56	1678 †	2.57
	3500	SQBI	1/2	2500	3.00	2423	3.12	2346	3.24	2254	3.31	2161	3.39	2065	3.45
	3500	HDBI	3/4	3416	3.41	3263	3.58	3098	3.69	2929	3.80	2730	3.84	2516	3.86
	3500	SQBI	3/4	3750	4.50	3635	4.68	3520	4.86	3381	4.97	3241	5.08	3097	5.18
	3500	HDBI	FULL	4457	4.68	4227	4.86	3946	4.93	3656	4.99	3353	5.01	2996	4.96
	3500	SQBI	FULL	5000	6.00	4846	6.24	4693	6.48	4508	6.63	4322	6.77	4130	6.90
HDBI-150	1750	SQBI	1/2	1535 †	.66	1321 †	.71	1040 †	.70						
	1750	SQBI	3/4	2303 †	1.00	1982 †	1.06	1560 †	1.05						
	1750	HDBI	FULL	2700 †	.96	2070 †	1.00								
	1750	SQBI	FULL	3071 †	1.33	2643 †	1.41	2080 †	1.41						
	3500	HDBI	1/2	3078	3.48	2965	3.64	2845	3.79	2703	3.86	2558	3.92	2405	3.97
	3500	SQBI	1/2	3355	4.82	3261	4.99	3166	5.15	3071	5.30	2967	5.40	2862	5.50
	3500	HDBI	3/4	4616	5.22	4448	5.46	4268	5.68	4054	5.78	3836	5.87	3608	5.96
	3500	SQBI	3/4	5033	7.24	4891	7.48	4750	7.72	4607	7.96	4451	8.11	4294	8.26
	3500	HDBI	FULL	6155	6.96	5930	7.28	5690	7.57	5405	7.71	5115	7.83	4810	7.94
	3500	SQBI	FULL	6710	9.65	6522	9.97	6333	10.30	6143	10.61	5934	10.81	5725	11.01
HDBI-160	1750	SQBI	1/2	2090 †	1.05	1873 †	1.13	1613 †	1.16	1183 †	1.08				
	1750	SQBI	3/4	3136	1.58	2809	1.69	2420	1.73	1775	1.61				
	1750	HDBI	FULL	3730	1.53	3080	1.61	2170	1.55						
	1750	SQBI	FULL	4181	2.11	3746	2.26	3227	2.31	2366	2.15				
	3500	HDBI	1/2	4125	5.56	4000	5.78	3875	5.99	3730	6.13	3570	6.22	3410	6.31
	3500	SQBI	1/2	4495	7.79	4390	8.03	4285	8.24	4181	8.44	4076	8.62	3969	8.77
	3500	HDBI	3/4	6188	8.34	6000	8.66	5813	8.99	5595	9.20	5355	9.33	5115	9.46
	3500	SQBI	3/4	6742	11.68	6584	12.04	6428	12.37	6271	12.66	6113	12.92	5953	13.16
	3500	HDBI	FULL	8250	11.12	8000	11.55	7750	11.98	7460	12.26	7140	12.44	6820	12.61
	3500	SQBI	FULL	8990	15.58	8779	16.06	8571	16.49	8362	16.88	8151	17.23	7937	17.54
HDBI-180	1750	SQBI	1/2	2871	1.71	2637	1.82	2378	1.89	2057	1.90	1489	1.73		
	1750	HDBI	3/4	3896	1.88	3371	1.97	2764	2.00						
	1750	SQBI	3/4	4307	2.56	3955	2.73	3567	2.84	3086	2.85	2233	2.59		
	1750	HDBI	FULL	5195	2.68	4495	2.83	3685	2.87						
	1750	SQBI	FULL	5743	3.42	5273	3.65	4756	3.78	4114	3.80	2978	3.45		
	3500	HDBI	1/2	5613	9.14	5473	9.43	5335	9.72	5198	10.01	5028	10.16	4853	10.28
	3500	SQBI	1/2	6091	12.76	5974	13.09	5858	13.39	5743	13.67	5627	13.93	5511	14.17
	3500	HDBI	3/4	8419	13.71	8209	14.15	8003	14.58	7796	15.02	7541	15.24	7279	15.42
	3500	SQBI	3/4	91.36	19.14	8961	19.63	8787	20.09	8614	20.51	8441	20.90	8267	21.25
	3500	HDBI	FULL	11225	18.28	10945	18.86	10670	19.44	10395	20.02	10055	20.32	9705	20.56
3500	SQBI	FULL	12181	25.52	11947	26.18	11716	26.79	11486	27.35	11255	27.87	11022	28.34	
HDBI-200	1750	SQBI	1/2	3934	2.85	3658	3.02	3371	3.16	3045	3.18	2612	3.09	1722	2.51
	1750	HDBI	3/4	5220	2.91	4676	3.07	4076	3.17	3293	3.11				
	1750	SQBI	3/4	5901	4.27	5487	4.53	5057	4.74	4568	4.77	3918	4.63	2583	3.77
	1750	HDBI	FULL	6960	3.88	6235	4.09	5435	4.23	4390	4.14				
	1750	SQBI	FULL	7868	5.69	7317	6.05	6743	6.33	6091	6.36	5224	6.18	3444	5.03
	3500	HDBI	1/2	7415	14.37	7265	14.75	7113	15.14	6960	15.52	6810	15.90	6620	16.07
	3500	SQBI	1/2	8268	21.53	8135	21.94	8001	22.35	7867	22.76	7734	23.17	7600	23.58
	3500	HDBI	3/4	11123	21.56	10898	22.13	10669	22.70	10440	23.27	10215	23.85	9930	24.10
	3500	SQBI	3/4	12403	32.29	12202	32.91	12002	33.52	11801	34.14	11601	34.76	11401	35.37
	3500	HDBI	FULL	14830	28.74	14530	29.50	14225	30.27	13920	31.03	13620	31.80	13240	32.13
3500	SQBI	FULL	16537	43.05	16270	43.88	16003	44.70	15735	45.52	15468	46.34	15201	47.16	

Performance shown is for installation type B-Free inlet, ducted outlet. Performance ratings do not include the effects of appurtenances (accessories).

CFM and BHP at Static Pressure Shown  
Ratings at 70°F., .075 Density, Sea Level

7" SP		8" SP		9" SP		10" SP		11" SP		12" SP		13" SP		14" SP	
CFM	BHP	CFM	BHP	CFM	BHP	CFM	BHP	CFM	BHP	CFM	BHP	CFM	BHP	CFM	BHP
† Requires a 143T frame or larger even though BHP is available in a 56 frame. See pages 25 or 26.															
1330 †	2.15	1201 †	2.11	1021	1.95										
1996	3.22	1801	3.16	1532	2.93										
1580 †	2.76	2402	4.21	2043	3.90										
2661	4.29														
1951	3.47	1838	3.48	1705	3.45	1559	3.39	1347	3.14						
2927	5.20	2758	5.22	2558	5.18	2339	5.08	2021	4.71						
2595	4.85	2172	4.71												
3903	6.93	3677	6.97	3411	6.91	3119	6.78	2695	6.28						
2255	4.03	2070	4.01												
2758	5.60	2643	5.66	2527	5.71	2406	5.74	2244	5.68	2081	5.62	1817	5.35	1086	4.39
3383	6.05	3105	6.02												
4137	8.41	3965	8.48	3791	8.56	3610	8.61	3367	8.52	3121	8.43	2725	8.02	1629	6.58
4510	8.06	4140	8.02	3700	7.87	3200	7.66								
5516	11.21	5287	11.31	5055	11.41	4813	11.49	4489	11.37	4162	11.24	3634	10.69	2173	8.77
See additional HDBI-160 ratings at bottom of page 10.															
3245	6.38	3080	6.45	2913	6.52	2680	6.43	3370	9.24	3227	9.25	3067	9.22	2885	9.14
3859	8.91	3746	9.03	3628	9.12	3503	9.20								
4868	9.57	4620	9.68	4369	9.78	4020	9.65	5056	13.86	4840	13.88	4601	13.83	4327	13.70
5788	13.36	5618	13.54	5441	13.68	5255	13.79	4870	12.64	4335	12.39	6134	18.45	5769	18.27
6490	12.76	6160	12.90	5825	13.04	5360	12.86	6741	18.48	6453	18.51				
7718	17.82	7491	18.05	7255	18.25	7006	18.39								
See additional HDBI-180 ratings at bottom of page 10.															
4675	10.40	4495	10.51	4310	10.60	4128	10.70	3943	10.80	4756	15.13	4612	15.20	4459	15.24
5393	14.39	5273	14.59	5150	14.75	5024	14.90	4893	15.03						
7013	15.60	6743	15.76	6465	15.90	6191	16.05	5914	16.19	7134	22.70	6918	22.80	6689	22.86
8090	21.58	7910	21.87	7726	22.13	7536	22.36	7339	22.55	7375	21.34	6865	21.08	6265	20.74
9350	20.80	8990	21.01	8620	21.20	8255	21.40	7885	21.59	9512	30.26	9224	30.40	8918	30.48
10786	28.77	10547	29.16	10301	29.51	10048	29.81	9786	30.06						
See additional HDBI-200 ratings at bottom of pages 10 & 11.															
6425	16.22	6323	16.38	6038	16.52	5838	16.65	5635	16.78	5425	16.92	5233	17.05	4968	16.94
7458	23.88	7317	24.18	7175	24.48	7033	24.78	6891	25.08	6743	25.30	6580	25.34	6417	25.38
9638	24.33	9349	24.56	9056	24.78	8756	24.98	8453	25.17	8153	25.37	7849	25.57	7451	25.40
11188	35.82	10975	36.27	10762	36.72	10550	37.17	10337	37.62	10115	37.95	9870	38.01	9626	38.07
12850	32.44	12465	32.75	12075	33.04	11675	33.30	11270	33.56	10870	33.83	10465	34.09	9935	33.87
14917	47.76	14364	48.36	14350	48.96	14066	49.56	13783	50.16	13487	50.60	13160	50.68	12834	50.76

# DIRECT DRIVE RATING TABLES (cont'd)

The partial width fan ratings shown on this page and on Pages 8, 9 and 11 were derived from tests performed in accordance with AMCA Publication 211 and fan laws were applied to arrive at the data shown for partial width fans.

However, none of the partial width fans or fans with SQBI wheels are licensed to bear the AMCA seal.

All 100% width fans with HDBI wheels are licensed to bear the AMCA seal as shown on pages 7 and 12 through 23.

MODEL NUMBER	RPM	WHEEL TYPE	FAN WIDTH	1" SP		2" SP		3" SP		4" SP		5" SP		6" SP	
				CFM	BHP	CFM	BHP	CFM	BHP	CFM	BHP	CFM	BHP	CFM	BHP
HDBI-220	1750	HDBI	1/2	4950	3.21	4635	3.45	4305	3.63	3878	3.70				
	1750	SQBI	1/2	5375	4.43	5104	4.69	4777	4.83	4443	4.97	4092	5.07	3655	5.08
	1750	HDBI	3/4	7425	4.81	6953	5.17	6548	5.45	5816	5.54				
	1750	SQBI	3/4	8063	6.65	7656	7.03	7166	7.25	6664	7.45	6138	7.60	5483	7.62
	1750	HDBI	FULL	9900	6.41	9270	6.89	8610	7.26	7755	7.39	6820	7.42		
	1750	SQBI	FULL	10750	8.87	10209	9.37	9555	9.67	8886	9.93	8184	10.13	7311	10.16
	3500	HDBI	1/2	10364	23.77	10209	24.34	10054	24.91	9899	25.48	9744	26.05	9589	26.62
	3500	HDBI	3/4	15547	35.66	15314	36.51	15081	37.37	14849	38.22	14616	39.08	14383	39.94
	3500	HDBI	FULL	20729	47.54	20419	48.68	20109	49.82	19799	50.97	19488	52.11	19178	53.25
HDBI-240	1750	HDBI	1/2	6683	5.11	6340	5.46	5980	5.72	5593	5.93	5103	5.99		
	1750	SQBI	1/2	7250	7.12	6955	7.47	6618	7.72	6258	7.92	5884	8.08	5497	8.21
	1750	HDBI	3/4	10024	7.67	9510	8.19	8970	8.58	8389	8.89	7654	8.98		
	1750	SQBI	3/4	10875	10.68	10433	11.20	9928	11.58	9388	11.87	8826	12.12	8246	12.32
	1750	HDBI	FULL	13365	10.22	12680	10.92	11960	11.44	11185	11.85	10205	11.97	9175	12.02
	1750	SQBI	FULL	14500	14.25	13911	14.93	13237	15.43	12517	15.83	11769	16.16	10995	16.43
HDBI-270	1750	HDBI	1/2	9443	8.81	9078	9.27	8703	9.69	8288	10.00	7873	10.32	7365	10.42
	1750	SQBI	1/2	9764	11.46	9440	11.92	9106	12.36	8709	12.62	8312	12.89	7898	13.10
	1750	HDBI	3/4	14161	13.22	13616	13.90	13054	14.53	12431	15.00	11803	15.47	11048	15.61
	1750	SQBI	3/4	14647	17.20	14161	17.89	13659	18.53	13064	18.93	12469	19.33	11848	19.65
	1750	HDBI	FULL	18885	17.62	18155	18.53	17405	19.37	16575	20.00	15745	20.63	14730	20.81
	1750	SQBI	FULL	19529	22.93	18881	23.85	18212	24.71	17418	25.24	16625	25.78	15797	26.21
HDBI-300	1750	HDBI	1/2	13048	14.77	12645	15.40	12240	16.02	11803	16.53	11340	16.96	10880	17.39
	1750	SQBI	1/2	13496	19.30	13136	19.94	12775	20.57	12377	21.08	11936	21.44	11495	21.81
	1750	HDBI	3/4	19571	22.16	18968	23.09	18360	24.03	17704	24.80	17010	25.44	16320	26.08
	1750	SQBI	3/4	20244	28.96	19704	29.91	19163	30.86	18565	31.61	17904	32.16	17242	32.71
	1750	HDBI	FULL	26095	29.54	25290	30.79	24480	32.04	23605	33.06	22680	33.92	21760	34.77
	1750	SQBI	FULL	26992	38.61	26272	39.87	25551	41.14	24754	42.15	23872	42.88	22990	43.61
HDBI-330	1750	HDBI	1/2	17453	23.38	17011	24.28	16568	25.19	16125	26.09	15627	26.71	15120	27.28
	1750	SQBI	1/2	19051	34.49	18555	35.13	18059	35.77	17538	36.25	16985	36.53	16432	36.81
	1750	HDBI	3/4	26180	35.07	25516	36.43	24852	37.78	24188	39.14	23441	40.07	22680	40.92
	1750	SQBI	3/4	28576	51.73	27832	52.69	27088	53.65	26307	54.38	25478	54.79	24648	55.21
	1750	HDBI	FULL	34907	46.77	34022	48.58	33136	50.38	32251	52.19	31254	53.42	30240	54.56
	1750	SQBI	FULL	38102	68.98	37110	70.26	36118	71.54	35076	72.50	33970	73.06	32864	73.62
HDBI-360	1750	HDBI	1/2	22751	35.91	22268	37.08	21785	38.25	21302	39.43	20814	40.57	20261	41.31
	1750	SQBI	1/2	25982	57.19	25433	58.06	24884	58.93	24336	59.79	23747	60.35	23134	60.73
	1750	HDBI	3/4	34127	53.86	33402	55.62	32678	57.38	31954	59.13	31221	60.85	30391	61.96
	1750	SQBI	3/4	38973	85.79	38150	87.09	37327	88.39	36504	89.69	35620	90.53	34702	91.10
	1750	HDBI	FULL	45503	71.82	44537	74.16	43571	76.51	42605	78.85	41629	81.13	40522	82.61

MODEL NUMBER	RPM	WHEEL TYPE	FAN WIDTH	15" SP		16" SP		17" SP		18" SP		19" SP		20" SP	
				CFM	BHP	CFM	BHP	CFM	BHP	CFM	BHP	CFM	BHP	CFM	BHP
HDBI-160	3500	SQBI	1/2	2664	8.96	2366	8.61								
	3500	SQBI	3/4	3996	13.44	3549	12.92								
	3500	SQBI	FULL	5328	17.92	4732	17.22								
HDBI-180	3500	SQBI	1/2	4295	15.24	4114	15.18								
	3500	SQBI	3/4	6442	22.86	6171	22.78								
	3500	SQBI	FULL	8589	30.47	8229	30.37								
HDBI-200	3500	SQBI	1/2	6254	25.42	6091	25.46	5922	25.47	5690	25.21	5457	24.96	5224	24.70
	3500	SQBI	3/4	9381	38.13	9137	38.18	8884	38.20	8535	37.82	8185	37.44	7836	37.06
	3500	SQBI	FULL	12508	50.83	12182	50.91	11845	50.94	11380	50.43	10914	49.92	10449	49.41
HDBI-220	3500	HDBI	1/2	7975	29.46	7753	29.55	7531	29.64	7309	29.73	7066	29.72	6822	29.70
	3500	HDBI	3/4	11963	44.19	11630	44.33	11297	44.46	10964	44.59	10600	44.58	10233	44.54
	3500	HDBI	FULL	15951	58.93	15507	59.10	15063	59.28	14619	59.46	14133	59.43	13644	59.39
HDBI-330	1750	SQBI	1/2	8235	31.96										
	1750	SQBI	3/4	12352	47.95										
	1750	SQBI	FULL	16470	63.93										
HDBI-360	1750	SQBI	1/2	16331	60.33	15064	59.99	13619	59.67	11878	55.24				
	1750	SQBI	3/4	24497	90.49	22597	89.99	20429	89.50	17817	82.87				

Performance shown is for installation type B-Free inlet, ducted outlet. Performance ratings do not include the effects of appurtenances (accessories).

CFM and BHP at Static Pressure Shown  
 Ratings at 70°F., .075 Density, Sea Level

7" SP		8" SP		9" SP		10" SP		11" SP		12" SP		13" SP		14" SP	
CFM	BHP	CFM	BHP	CFM	BHP	CFM	BHP	CFM	BHP	CFM	BHP	CFM	BHP	CFM	BHP
3061	4.96														
4591	7.43														
6122	9.91														
9434	27.19	9269	27.56	9105	27.93	8940	28.31	8776	28.68	8611	29.05	8420	29.29	8198	29.37
14151	40.79	13904	41.35	13657	41.90	13411	42.46	13164	43.02	12917	43.57	12630	43.93	12297	44.06
18868	54.39	18539	55.13	18210	55.87	17881	56.61	17552	57.35	17223	58.10	16840	58.57	16396	58.75
5045	8.27	4464	8.17	3641	7.81										
7567	12.40	6696	12.25	5462	11.71										
10090	16.53	8929	16.34	7283	15.61										
7472	13.28	7046	13.46	6437	13.37	5731	13.16	4756	12.55						
11208	19.92	10569	20.19	9655	20.05	8597	19.74	7134	18.83						
13625	20.87	11950	20.29												
14945	26.56	14092	26.92	12874	26.73	11463	26.32	9512	25.10						
10343	17.60														
11044	22.13	10570	22.38	10097	22.62	9607	22.84	8923	22.70	8198	22.50	7281	22.03	5851	20.43
15514	26.39														
16566	33.20	15856	33.57	15145	33.93	14411	34.26	13385	34.05	12297	33.75	10922	33.05	8776	30.65
20685	35.19	19515	35.34	18025	35.05										
22089	44.27	21141	44.76	20194	45.25	19215	45.68	17847	45.39	16396	45.00	14562	44.06	11702	40.86
14613	27.85	14066	28.28	13423	28.38	12780	28.48	11882	28.16	10856	27.64				
15875	37.07	15208	37.00	14542	36.92	13866	36.83	13046	36.57	12225	36.32	11166	36.07	9860	35.83
21920	41.77	21100	42.42	20135	42.58	19170	42.73	17823	42.25	16285	41.45				
23812	55.61	22812	55.50	21813	55.38	20799	55.24	19569	54.86	18338	54.47	16749	54.10	14791	53.74
29226	55.71	28133	56.57	26846	56.77	25560	56.98	23764	56.34	21713	55.28				
31750	74.15	30417	73.99	29084	73.84	27732	73.66	26092	73.15	24451	72.63	22332	72.14	19721	71.66
19708	42.05	19154	42.78	18601	43.53	17925	43.76	17224	43.89	16523	44.03	15528	43.58	14408	42.89
22522	61.11	21909	61.49	21239	61.65	20501	61.54	19763	61.43	19025	61.33	18148	61.02	17240	60.68
29562	63.07	28732	64.18	27902	65.29	26888	65.64	25836	65.84	24784	66.04	23292	65.37	21613	64.37
33783	91.67	32864	92.24	31858	92.47	30752	92.31	29645	92.15	28538	91.99	27223	91.54	25860	91.01
39416	84.10	38309	85.58	37203	87.06	35851	87.53	34448	87.80	33046	88.06	31056	87.17	28817	85.80

See additional HDBI-220 ratings at bottom of page 10 and this page.

See additional HDBI-330 and HDBI-360 ratings at bottom of page 10.

21" SP		22" SP		23" SP		24" SP		25" SP		26" SP		27" SP		28" SP	
CFM	BHP	CFM	BHP	CFM	BHP	CFM	BHP	CFM	BHP	CFM	BHP	CFM	BHP	CFM	BHP
4950	24.32	4616	23.74	4282	23.16	3444	20.10	2845	17.59						
7426	36.48	6924	35.60	6423	34.73	5166	30.15	4267	26.39						
9901	48.63	9233	47.47	8564	46.31	6888	40.20	5690	35.18						
6577	29.68	6072	29.04	5522	28.29										
9865	44.51	9108	43.56	8283	42.44										
13154	59.35	12144	58.07	11044	56.58										

# HDBI-120

**WHEEL**  
Dia. - 12.25"

**OUTLET O.D.**  
Size - 9.38" x 13.69"  
Area - .85 Sq. Ft. I.D.

**INLET O.D.**  
Size - 13.25"  
Area - .93 Sq.Ft. I.D.

## BELT DRIVE RATING TABLES

Ratings at 70°F., .075 Density, Sea Level

All wheels are HDBI type  
Class II = light face above Class III  
**Class III = bold face**

SEE PAGE 24 FOR MAX. WHEEL RPM & WR<sup>2</sup>.

VOLUME CFM	O.V. FPM	0" SP		1/4" SP		1/2" SP		3/4" SP		1" SP		1 1/2" SP		2" SP	
		RPM	BHP	RPM	BHP	RPM	BHP	RPM	BHP	RPM	BHP	RPM	BHP	RPM	BHP
600	705	589	.01	812	.04	995	.07	1164	.11	1324	.15				
750	882	737	.02	920	.06	1084	.09	1227	.13	1366	.18				
900	1058	884	.04	1045	.08	1185	.12	1316	.17	1437	.21	1666	.32	1883	.44
1050	1235	1032	.07	1173	.11	1294	.16	1415	.21	1526	.26	1730	.37	1928	.50
1200	1411	1179	.10	1305	.15	1416	.20	1522	.26	1625	.32	1818	.44	1990	.57
1350	1588	1326	.14	1440	.20	1543	.26	1636	.32	1731	.38	1909	.51	2078	.65
1500	1764	1474	.19	1578	.26	1672	.33	1760	.39	1841	.46	2011	.60	2168	.75
1650	1941	1621	.25	1717	.33	1803	.41	1887	.48	1964	.55	2118	.70	2265	.86
1800	2117	1768	.33	1857	.41	1938	.50	2015	.57	2089	.65	2227	.81	2370	.98
1950	2294	1916	.42	1998	.51	2074	.60	2146	.69	2217	.77	2347	.94	2478	1.12
2100	2470	2063	.52	2140	.62	2211	.71	2279	.81	2346	.90	2471	1.08	2587	1.27
2250	2647	2211	.64	2282	.74	2350	.85	2414	.95	2477	1.06	2597	1.25	2709	1.44
2400	2823	2358	.78	2425	.89	2490	1.00	2551	1.11	2609	1.23	2725	1.43	2833	1.63
2550	3000	2505	.93	2569	1.05	2630	1.16	2688	1.28	2744	1.41	2854	1.63	2958	1.85
2700	3176	2653	1.11	2713	1.23	2771	1.35	2827	1.48	2880	1.61	2985	1.85	3086	2.08
2850	3352	2800	1.30	2857	1.43	2913	1.56	2966	1.69	3017	1.83	3116	2.09	3214	2.33

VOLUME CFM	O.V. FPM	2 1/2" SP		3" SP		4" SP		5" SP		6" SP		7" SP		8" SP	
		RPM	BHP	RPM	BHP	RPM	BHP	RPM	BHP	RPM	BHP	RPM	BHP	RPM	BHP
1050	1235	2116	.64	2295	.78	2614	1.09								
1200	1411	2165	.71	2329	.86	2647	1.20	2928	1.55						
1350	1588	2230	.80	2386	.96	2681	1.30	2961	1.68	3215	2.07				
1500	1764	2317	.90	2455	1.06	2732	1.42	2995	1.81	3249	2.23	3482	2.66	3699	3.11
1650	1941	2407	1.02	2543	1.19	2792	1.56	3044	1.96	3283	2.39	3516	2.84	3733	3.32
1800	2117	2501	1.15	2632	1.34	2874	1.72	3103	2.12	3331	2.57	3550	3.03	3767	3.53
1950	2294	2606	1.30	2725	1.49	2963	1.89	3177	2.31	3391	2.76	3601	3.24	3801	3.74
2100	2470	2713	1.47	2829	1.67	3053	2.09	3265	2.52	3459	2.98	3660	3.47	3855	3.99
2250	2647	2821	1.65	2935	1.86	3145	2.29	3354	2.76	3546	3.23	3726	3.72	3915	4.25
2400	2823	2934	1.85	3043	2.07	3250	2.53	3445	3.00	3635	3.50	3813	4.01	3980	4.53
2550	3000	3057	2.07	3153	2.30	3355	2.78	3540	3.27	3726	3.79	3901	4.32	4067	4.86
2700	3176	3181	2.31	3272	2.55	3463	3.05	3645	3.56	3817	4.10	3991	4.65	4155	5.21
2850	3352	3307	2.58	3395	2.83	3571	3.34	3751	3.88	3918	4.43	4082	5.00	<b>4245</b>	<b>5.59</b>
3000	3529	3434	2.87	3520	3.13	3682	3.66	3858	4.22	4022	4.79	4177	5.37	<b>4336</b>	<b>5.98</b>
3150	3705	3562	3.18	3646	3.45	3804	4.00	3966	4.58	4128	5.17	<b>4281</b>	<b>5.78</b>	<b>4427</b>	<b>6.40</b>
3300	3882	3692	3.52	3773	3.80	3928	4.38	4076	4.96	<b>4236</b>	<b>5.58</b>	<b>4387</b>	<b>6.21</b>	<b>4530</b>	<b>6.85</b>
3450	4058	3822	3.89	3902	4.18	4053	4.78	<b>4194</b>	<b>5.38</b>	<b>4344</b>	<b>6.01</b>	<b>4493</b>	<b>6.67</b>	<b>4635</b>	<b>7.33</b>
3600	4235	3953	4.29	4031	4.59	4178	5.20	<b>4317</b>	<b>5.83</b>	<b>4454</b>	<b>6.48</b>	<b>4601</b>	<b>7.15</b>	<b>4741</b>	<b>7.83</b>
3750	4411	4086	4.71	4161	5.02	<b>4305</b>	<b>5.66</b>	<b>4442</b>	<b>6.31</b>	<b>4571</b>	<b>6.97</b>	<b>4710</b>	<b>7.66</b>	<b>4848</b>	<b>8.37</b>
3900	4588	<b>4220</b>	<b>5.15</b>	<b>4293</b>	<b>5.49</b>	<b>4433</b>	<b>6.15</b>	<b>4567</b>	<b>6.82</b>	<b>4694</b>	<b>7.50</b>	<b>4820</b>	<b>8.20</b>	<b>4956</b>	<b>8.93</b>
4050	4764	<b>4355</b>	<b>5.62</b>	<b>4425</b>	<b>5.99</b>	<b>4562</b>	<b>6.67</b>	<b>4693</b>	<b>7.37</b>	<b>4817</b>	<b>8.07</b>	<b>4937</b>	<b>8.78</b>		
4200	4941	<b>4491</b>	<b>6.11</b>	<b>4558</b>	<b>6.52</b>	<b>4692</b>	<b>7.23</b>	<b>4820</b>	<b>7.94</b>	<b>4942</b>	<b>8.67</b>				

VOLUME CFM	O.V. FPM	9" SP		10" SP		11" SP		12" SP		13" SP		14" SP	
		RPM	BHP	RPM	BHP	RPM	BHP	RPM	BHP	RPM	BHP	RPM	BHP
1800	2117	3971	4.03	4164	4.56	<b>4347</b>	<b>5.09</b>						
1950	2294	4004	4.27	<b>4197</b>	<b>4.82</b>	<b>4381</b>	<b>5.37</b>	<b>4556</b>	<b>5.95</b>	<b>4724</b>	<b>6.53</b>		
2100	2470	4039	4.52	<b>4231</b>	<b>5.08</b>	<b>4414</b>	<b>5.66</b>	<b>4590</b>	<b>6.26</b>	<b>4758</b>	<b>6.86</b>	4920	7.48
2250	2647	4098	4.80	<b>4272</b>	<b>5.37</b>	<b>4448</b>	<b>5.96</b>	<b>4623</b>	<b>6.57</b>	<b>4791</b>	<b>7.20</b>	<b>4953</b>	<b>7.84</b>
2400	2823	4157	5.10	<b>4331</b>	<b>5.68</b>	<b>4496</b>	<b>6.28</b>	<b>4658</b>	<b>6.90</b>	<b>4825</b>	<b>7.55</b>		
2550	3000	<b>4224</b>	<b>5.42</b>	<b>4390</b>	<b>6.01</b>	<b>4555</b>	<b>6.64</b>	<b>4713</b>	<b>7.27</b>	<b>4865</b>	<b>7.91</b>		
2700	3176	<b>4311</b>	<b>5.79</b>	<b>4459</b>	<b>6.38</b>	<b>4615</b>	<b>7.00</b>	<b>4772</b>	<b>7.66</b>	<b>4924</b>	<b>8.32</b>		
2850	3352	<b>4399</b>	<b>6.18</b>	<b>4546</b>	<b>6.79</b>	<b>4687</b>	<b>7.41</b>	<b>4832</b>	<b>8.06</b>	<b>4983</b>	<b>8.75</b>		
3000	3529	<b>4489</b>	<b>6.60</b>	<b>4635</b>	<b>7.23</b>	<b>4775</b>	<b>7.87</b>	<b>4909</b>	<b>8.52</b>				
3150	3705	<b>4579</b>	<b>7.04</b>	<b>4724</b>	<b>7.69</b>	<b>4863</b>	<b>8.35</b>						
3300	3882	<b>4671</b>	<b>7.50</b>	<b>4815</b>	<b>8.18</b>	<b>4952</b>	<b>8.86</b>						
3450	4058	<b>4770</b>	<b>8.00</b>	<b>4906</b>	<b>8.69</b>								

Performance certified is for installation type B - Free inlet, Ducted Outlet. Performance ratings do not include the effects of appurtenances (accessories). Power rating (BHP) does not include transmission losses.

# HDBI-130

**WHEEL**  
Dia. - 13.50"

**OUTLET O.D.**  
Size - 10.38" x 15.19"  
Area - 1.05 Sq. Ft. I.D.

**INLET O.D.**  
Size - 14.63"  
Area - 1.14 Sq.Ft. I.D.

## BELT DRIVE RATING TABLES

Ratings at 70°F., .075 Density, Sea Level

All wheels are HDBI type  
Class II = light face above Class III  
**Class III = bold face**  
Class IV = italic face below Class III

SEE PAGE 24 FOR MAX. WHEEL RPM & WR<sup>2</sup>.

VOLUME CFM	O.V. FPM	0" SP		1/4" SP		1/2" SP		3/4" SP		1" SP		1 1/2" SP		2" SP		2 1/2" SP	
		RPM	BHP	RPM	BHP	RPM	BHP	RPM	BHP	RPM	BHP	RPM	BHP	RPM	BHP	RPM	BHP
900	857	672	.03	867	.08	1027	.13	1167	.18	1290	.24	1500	.37	1706	.51	1892	.67
1100	1047	821	.06	986	.11	1129	.17	1257	.23	1372	.30	1579	.44	1756	.60	1921	.76
1300	1238	971	.10	1111	.16	1242	.22	1356	.29	1465	.37	1661	.52	1835	.69	1990	.87
1500	1428	1120	.15	1241	.22	1361	.29	1468	.37	1565	.45	1751	.62	1918	.81	2071	1.00
1700	1619	1269	.21	1378	.29	1484	.37	1583	.46	1677	.55	1847	.73	2007	.93	2153	1.14
1900	1809	1419	.30	1518	.39	1611	.48	1705	.57	1792	.67	1952	.87	2102	1.08	2243	1.30
2100	2000	1568	.40	1658	.50	1741	.60	1829	.70	1911	.81	2064	1.02	2202	1.25	2339	1.49
2300	2190	1717	.53	1801	.64	1877	.74	1956	.85	2034	.97	2179	1.20	2313	1.44	2436	1.69
2500	2380	1866	.68	1944	.79	2016	.91	2084	1.03	2159	1.15	2297	1.40	2426	1.66	2546	1.93
2700	2571	2016	.86	2088	.98	2155	1.10	2219	1.23	2286	1.36	2419	1.63	2541	1.91	2658	2.19
2900	2761	2165	1.06	2232	1.20	2296	1.33	2356	1.46	2415	1.60	2543	1.89	2660	2.18	2772	2.48
3100	2952	2314	1.30	2378	1.44	2438	1.58	2495	1.72	2550	1.87	2669	2.17	2782	2.48	2889	2.80
3300	3142	2464	1.57	2523	1.72	2580	1.87	2635	2.02	2687	2.17	2796	2.49	2906	2.82	3009	3.15
3500	3333	2613	1.87	2669	2.03	2723	2.19	2775	2.35	2826	2.51	2925	2.84	3031	3.19	3132	3.54
3700	3523	2762	2.21	2816	2.38	2867	2.54	2917	2.71	2965	2.89	3057	3.23	3158	3.59	3255	3.96
3900	3714	2912	2.59	2962	2.76	3012	2.94	3059	3.12	3105	3.30	3194	3.66	3286	4.04	3381	4.42
4100	3904	3061	3.01	3109	3.19	3156	3.38	3202	3.56	3246	3.75	3332	4.13	3415	4.52	3507	4.92
4300	4095	3210	3.47	3257	3.66	3301	3.86	3345	4.05	3388	4.25	3470	4.65	3549	5.05	3635	5.47
4500	4285	3360	3.98	3404	4.18	3447	4.38	3489	4.59	3530	4.79	3609	5.21	3686	5.63	3764	6.06
4700	4476	3509	4.53	3551	4.74	3593	4.95	3633	5.17	3673	5.38	3749	5.82	3823	6.25	<b>3895</b>	<b>6.69</b>

VOLUME CFM	O.V. FPM	3" SP		4" SP		5" SP		6" SP		7" SP		8" SP		9" SP		10" SP	
		RPM	BHP	RPM	BHP	RPM	BHP	RPM	BHP	RPM	BHP	RPM	BHP	RPM	BHP	RPM	BHP
1500	1428	2211	1.20	2461	1.63	2708	2.10	2946	2.60	3165	3.12	3368	3.65	3560	4.21	3741	4.79
1700	1619	2292	1.36	2540	1.82	2760	2.31	2975	2.83	3193	3.38	3397	3.95	3588	4.54	3769	5.15
1900	1809	2375	1.54	2620	2.03	2839	2.54	3039	3.08	3223	3.65	3426	4.25	3617	4.88	3798	5.52
2100	2000	2466	1.73	2703	2.25	2920	2.80	3118	3.37	3301	3.96	3472	4.58	3646	5.22	3827	5.90
2300	2190	2562	1.95	2789	2.50	3002	3.08	3198	3.68	3380	4.30	3550	4.95	3711	5.61	<b>3863</b>	<b>6.29</b>
2500	2380	2659	2.20	2883	2.78	3086	3.38	3281	4.01	3461	4.67	3630	5.34	3790	6.03	<b>3941</b>	<b>6.75</b>
2700	2571	2767	2.48	2979	3.08	3178	3.71	3364	4.37	3543	5.06	3711	5.76	<b>3870</b>	<b>6.49</b>	<b>4021</b>	<b>7.23</b>
2900	2761	2879	2.78	3077	3.41	3274	4.07	3454	4.76	3627	5.47	3793	6.21	<b>3951</b>	<b>6.96</b>	<b>4101</b>	<b>7.74</b>
3100	2952	2993	3.12	3186	3.78	3370	4.46	3549	5.18	3716	5.92	<b>3877</b>	<b>6.68</b>	<b>4034</b>	<b>7.47</b>	<b>4183</b>	<b>8.27</b>
3300	3142	3108	3.49	3297	4.18	3471	4.89	3645	5.64	3811	6.41	<b>3966</b>	<b>7.20</b>	<b>4117</b>	<b>8.01</b>	<b>4265</b>	<b>8.84</b>
3500	3333	3227	3.89	3410	4.62	3581	5.36	3743	6.13	<b>3906</b>	<b>6.93</b>	<b>4060</b>	<b>7.75</b>	<b>4207</b>	<b>8.59</b>	<b>4349</b>	<b>9.44</b>
3700	3523	3348	4.33	3525	5.09	3692	5.87	<b>3849</b>	<b>6.66</b>	<b>4004</b>	<b>7.49</b>	<b>4156</b>	<b>8.34</b>	<b>4301</b>	<b>9.21</b>	<b>4439</b>	<b>10.09</b>
3900	3714	3471	4.81	3641	5.60	3806	6.42	<b>3959</b>	<b>7.24</b>	<b>4104</b>	<b>8.08</b>	<b>4253</b>	<b>8.97</b>	<b>4396</b>	<b>9.87</b>	<b>4533</b>	<b>10.79</b>
4100	3904	3595	5.33	3761	6.16	<b>3920</b>	<b>7.00</b>	<b>4071</b>	<b>7.86</b>	<b>4214</b>	<b>8.74</b>	<b>4351</b>	<b>9.63</b>	<b>4493</b>	<b>10.57</b>	<b>4629</b>	<b>11.52</b>
4300	4095	3721	5.89	<b>3883</b>	<b>6.76</b>	<b>4036</b>	<b>7.63</b>	<b>4185</b>	<b>8.53</b>	<b>4325</b>	<b>9.44</b>	<b>4459</b>	<b>10.36</b>	<b>4591</b>	<b>11.31</b>	<b>4726</b>	<b>12.29</b>
4500	4285	<b>3847</b>	<b>6.50</b>	<b>4006</b>	<b>7.40</b>	<b>4155</b>	<b>8.31</b>	<b>4299</b>	<b>9.24</b>	<b>4438</b>	<b>10.18</b>	<b>4570</b>	<b>11.14</b>	<b>4696</b>	<b>12.11</b>	<i>4823</i>	<i>13.11</i>
4700	4476	<b>3975</b>	<b>7.15</b>	<b>4130</b>	<b>8.09</b>	<b>4276</b>	<b>9.03</b>	<b>4415</b>	<b>9.99</b>	<b>4552</b>	<b>10.97</b>	<b>4682</b>	<b>11.96</b>	<i>4806</i>	<i>12.96</i>	<i>4926</i>	<i>13.98</i>
4900	4666	<b>4104</b>	<b>7.86</b>	<b>4255</b>	<b>8.82</b>	<b>4398</b>	<b>9.80</b>	<b>4534</b>	<b>10.80</b>	<b>4667</b>	<b>11.81</b>	<i>4795</i>	<i>12.83</i>	<i>4918</i>	<i>13.87</i>		
5100	4857	<b>4234</b>	<b>8.61</b>	<b>4382</b>	<b>9.61</b>	<b>4522</b>	<b>10.63</b>	<b>4654</b>	<b>11.66</b>	<i>4783</i>	<i>12.70</i>	<i>4909</i>	<i>13.76</i>				

VOLUME CFM	O.V. FPM	11" SP		12" SP		13" SP		14" SP		15" SP		16" SP		17" SP	
		RPM	BHP	RPM	BHP	RPM	BHP	RPM	BHP	RPM	BHP	RPM	BHP	RPM	BHP
1900	1809	<b>3970</b>	<b>6.18</b>	<b>4134</b>	<b>6.85</b>	<b>4292</b>	<b>7.54</b>	<b>4444</b>	<b>8.25</b>	<b>4590</b>	<b>8.97</b>	<b>4732</b>	<b>9.70</b>		
2100	2000	<b>3999</b>	<b>6.59</b>	<b>4163</b>	<b>7.30</b>	<b>4320</b>	<b>8.02</b>	<b>4472</b>	<b>8.76</b>	<b>4619</b>	<b>9.51</b>	<b>4760</b>	<b>10.28</b>	<i>4898</i>	<i>11.06</i>
2300	2190	<b>4027</b>	<b>7.01</b>	<b>4192</b>	<b>7.75</b>	<b>4349</b>	<b>8.51</b>	<b>4501</b>	<b>9.28</b>	<b>4647</b>	<b>10.06</b>	<b>4789</b>	<b>10.86</b>	<i>4926</i>	<i>11.67</i>
2500	2380	<b>4086</b>	<b>7.47</b>	<b>4224</b>	<b>8.22</b>	<b>4378</b>	<b>9.00</b>	<b>4530</b>	<b>9.81</b>	<b>4676</b>	<b>10.63</b>	<i>4818</i>	<i>11.46</i>	<i>4955</i>	<i>12.30</i>
2700	2571	<b>4164</b>	<b>7.99</b>	<b>4302</b>	<b>8.76</b>	<b>4435</b>	<b>9.55</b>	<b>4563</b>	<b>10.36</b>	<b>4705</b>	<b>11.20</b>	<i>4847</i>	<i>12.07</i>	<i>4984</i>	<i>12.95</i>
2900	2761	<b>4244</b>	<b>8.53</b>	<b>4381</b>	<b>9.33</b>	<b>4513</b>	<b>10.15</b>	<b>4641</b>	<b>10.99</b>	<i>4764</i>	<i>11.84</i>	<i>4883</i>	<i>12.70</i>		
3100	2952	<b>4325</b>	<b>9.09</b>	<b>4461</b>	<b>9.93</b>	<b>4593</b>	<b>10.78</b>	<b>4719</b>	<b>11.65</b>	<i>4842</i>	<i>12.53</i>	<i>4961</i>	<i>13.42</i>		
3300	3142	<b>4407</b>	<b>9.70</b>	<b>4543</b>	<b>10.56</b>	<b>4673</b>	<b>11.44</b>	<i>4799</i>	<i>12.34</i>	<i>4921</i>	<i>13.25</i>				
3500	3333	<b>4490</b>	<b>10.33</b>	<b>4625</b>	<b>11.23</b>	<i>4755</i>	<i>12.14</i>	<i>4880</i>	<i>13.07</i>						
3700	3523	<b>4574</b>	<b>11.00</b>	<b>4708</b>	<b>11.93</b>	<i>4837</i>	<i>12.87</i>	<i>4962</i>	<i>13.83</i>						
3900	3714	<b>4665</b>	<b>11.72</b>	<i>4792</i>	<i>12.66</i>	<i>4921</i>	<i>13.64</i>								
4100	3904	<i>4759</i>	<i>12.48</i>	<i>4885</i>	<i>13.46</i>										

Performance certified is for installation type B - Free inlet, Ducted Outlet. Performance ratings do not include the effects of appurtenances (accessories). Power rating (BHP) does not include transmission losses.

# HDBI-150

**WHEEL**  
Dia. - 15.00"

**OUTLET O.D.**  
Size - 11.38" x 16.75"  
Area - 1.28 Sq. Ft. I.D.

**INLET O.D.**  
Size - 16.13"  
Area - 1.39 Sq.Ft. I.D.

## BELT DRIVE RATING TABLES

Ratings at 70°F., .075 Density, Sea Level

All wheels are HDBI type  
Class II = light face above Class III  
**Class III = bold face**  
Class IV = italic face below Class III

SEE PAGE 24 FOR MAX. WHEEL RPM & WR<sup>2</sup>.

VOLUME CFM	O.V. FPM	0" SP		1/4" SP		1/2" SP		3/4" SP		1" SP		1 1/2" SP		2" SP		2 1/2" SP	
		RPM	BHP	RPM	BHP	RPM	BHP	RPM	BHP	RPM	BHP	RPM	BHP	RPM	BHP	RPM	BHP
1750	1367	959	.14	1062	.21	1165	.29	1258	.37	1341	.45	1502	.63	1651	.83	1789	1.04
2000	1562	1096	.20	1188	.29	1278	.37	1364	.46	1444	.56	1585	.75	1728	.96	1858	1.18
2250	1757	1233	.29	1316	.38	1394	.48	1475	.58	1550	.68	1686	.89	1809	1.12	1936	1.35
2500	1953	1370	.40	1446	.50	1514	.61	1589	.72	1659	.83	1789	1.06	1907	1.30	2017	1.55
2750	2148	1507	.53	1576	.64	1640	.76	1705	.88	1772	1.00	1895	1.25	2009	1.50	2114	1.77
3000	2343	1644	.68	1708	.81	1768	.93	1824	1.07	1887	1.20	2005	1.46	2114	1.74	2216	2.02
3250	2539	1781	.87	1840	1.00	1896	1.14	1949	1.28	2003	1.42	2117	1.71	2221	2.00	2320	2.30
3500	2734	1918	1.09	1973	1.23	2026	1.38	2076	1.53	2124	1.68	2230	1.98	2331	2.30	2425	2.61
3750	2929	2055	1.33	2107	1.49	2156	1.65	2204	1.81	2249	1.97	2346	2.29	2443	2.62	2534	2.96
4000	3125	2192	1.62	2241	1.78	2288	1.95	2333	2.12	2376	2.29	2463	2.64	2557	2.99	2645	3.35
4250	3320	2329	1.94	2375	2.12	2419	2.29	2462	2.47	2504	2.66	2583	3.02	2672	3.39	2757	3.77
4500	3515	2466	2.31	2510	2.49	2552	2.68	2593	2.87	2632	3.06	2708	3.45	2788	3.84	2871	4.23
4750	3710	2603	2.71	2644	2.91	2685	3.10	2724	3.30	2761	3.50	2834	3.91	2906	4.33	2986	4.74
5000	3906	2740	3.16	2779	3.37	2818	3.58	2855	3.79	2891	4.00	2962	4.42	3029	4.86	3103	5.29
5250	4101	2877	3.66	2915	3.88	2951	4.09	2987	4.31	3022	4.53	3089	4.98	3154	5.44	3220	5.89
5500	4296	3014	4.21	3050	4.44	3085	4.66	3119	4.89	3153	5.12	3218	5.59	3281	6.06	3341	6.54
5750	4492	3151	4.81	3185	5.05	3219	5.28	3252	5.52	3284	5.76	3347	6.25	3408	6.74	3466	7.24
6000	4687	3288	5.47	3321	5.71	3353	5.96	3385	6.21	3416	6.46	3477	6.97	<b>3535</b>	<b>7.48</b>	<b>3592</b>	<b>8.00</b>
6250	4882	3425	6.18	3457	6.43	3488	6.69	<b>3518</b>	<b>6.95</b>	<b>3548</b>	<b>7.21</b>	<b>3607</b>	<b>7.74</b>	<b>3664</b>	<b>8.27</b>	<b>3719</b>	<b>8.81</b>
6500	5078	<b>3562</b>	<b>6.95</b>	<b>3593</b>	<b>7.21</b>	<b>3623</b>	<b>7.48</b>	<b>3652</b>	<b>7.75</b>	<b>3681</b>	<b>8.02</b>	<b>3738</b>	<b>8.57</b>	<b>3793</b>	<b>9.12</b>	<b>3846</b>	<b>9.68</b>

VOLUME CFM	O.V. FPM	3" SP		4" SP		5" SP		6" SP		7" SP		8" SP		9" SP		10" SP	
		RPM	BHP	RPM	BHP	RPM	BHP	RPM	BHP	RPM	BHP	RPM	BHP	RPM	BHP	RPM	BHP
1750	1367	1917	1.26	2175	1.77	2403	2.33										
2000	1562	1982	1.42	2210	1.92	2438	2.51	2644	3.14								
2250	1757	2053	1.60	2273	2.13	2473	2.70	2679	3.35	2868	4.04	3045	4.76				
2500	1953	2132	1.81	2342	2.36	2536	2.96	2714	3.58	2903	4.30	3079	5.05	3245	5.83	3402	6.63
2750	2148	2213	2.05	2418	2.63	2606	3.25	2782	3.90	2944	4.58	3115	5.34	3280	6.15	3437	6.99
3000	2343	2310	2.31	2499	2.93	2680	3.57	2851	4.25	3013	4.96	3164	5.70	3315	6.49	3472	7.36
3250	2539	2412	2.61	2582	3.25	2760	3.93	2924	4.63	3083	5.37	3233	6.14	3374	6.93	3509	7.75
3500	2734	2516	2.94	2682	3.62	2841	4.32	3004	5.06	3155	5.81	3303	6.61	3443	7.44	<b>3577</b>	<b>8.28</b>
3750	2929	2621	3.31	2784	4.02	2934	4.75	3085	5.52	3235	6.31	3376	7.12	<b>3514</b>	<b>7.97</b>	<b>3647</b>	<b>8.85</b>
4000	3125	2728	3.71	2888	4.45	3034	5.22	3171	6.01	3315	6.84	3455	7.69	<b>3588</b>	<b>8.55</b>	<b>3717</b>	<b>9.45</b>
4250	3320	2838	4.15	2993	4.93	3136	5.73	3270	6.56	3397	7.41	<b>3536</b>	<b>8.29</b>	<b>3667</b>	<b>9.19</b>	<b>3792</b>	<b>10.11</b>
4500	3515	2950	4.63	3099	5.45	3240	6.29	3372	7.15	3496	8.03	<b>3618</b>	<b>8.93</b>	<b>3748</b>	<b>9.87</b>	<b>3872</b>	<b>10.83</b>
4750	3710	3063	5.16	3208	6.01	3345	6.89	3475	7.78	<b>3597</b>	<b>8.70</b>	<b>3713</b>	<b>9.63</b>	<b>3829</b>	<b>10.59</b>	<b>3953</b>	<b>11.58</b>
5000	3906	3177	5.73	3319	6.62	3452	7.53	3579	8.46	<b>3699</b>	<b>9.41</b>	<b>3814</b>	<b>10.38</b>	<b>3923</b>	<b>11.37</b>	<b>4034</b>	<b>12.38</b>
5250	4101	3293	6.35	3431	7.28	<b>3560</b>	<b>8.22</b>	<b>3684</b>	<b>9.19</b>	<b>3803</b>	<b>10.18</b>	<b>3916</b>	<b>11.18</b>	<b>4024</b>	<b>12.21</b>	<b>4127</b>	<b>13.24</b>
5500	4296	3409	7.02	<b>3544</b>	<b>7.99</b>	<b>3670</b>	<b>8.97</b>	<b>3791</b>	<b>9.97</b>	<b>3907</b>	<b>10.99</b>	<b>4018</b>	<b>12.04</b>	<b>4125</b>	<b>13.09</b>	<b>4228</b>	<b>14.17</b>
5750	4492	<b>3527</b>	<b>7.74</b>	<b>3658</b>	<b>8.75</b>	<b>3782</b>	<b>9.77</b>	<b>3899</b>	<b>10.80</b>	<b>4013</b>	<b>11.86</b>	<b>4123</b>	<b>12.94</b>	<b>4228</b>	<b>14.03</b>	<b>4329</b>	<b>15.14</b>
6000	4687	<b>3648</b>	<b>8.52</b>	<b>3774</b>	<b>9.56</b>	<b>3894</b>	<b>10.62</b>	<b>4009</b>	<b>11.69</b>	<b>4120</b>	<b>12.79</b>	<b>4228</b>	<b>13.90</b>	<b>4331</b>	<b>15.03</b>	<i>4431</i>	<i>16.18</i>
6250	4882	<b>3773</b>	<b>9.35</b>	<b>3890</b>	<b>10.44</b>	<b>4008</b>	<b>11.53</b>	<b>4121</b>	<b>12.65</b>	<b>4229</b>	<b>13.77</b>	<b>4334</b>	<b>14.92</b>	<i>4436</i>	<i>16.09</i>	<i>4535</i>	<i>17.27</i>
6500	5078	<b>3899</b>	<b>10.24</b>	<b>4007</b>	<b>11.37</b>	<b>4123</b>	<b>12.51</b>	<b>4233</b>	<b>13.66</b>	<b>4339</b>	<b>14.82</b>	<i>4441</i>	<i>16.00</i>	<i>4542</i>	<i>17.20</i>	<i>4639</i>	<i>18.42</i>

VOLUME CFM	O.V. FPM	11" SP		12" SP		13" SP		14" SP		15" SP		16" SP		17" SP		18" SP	
		RPM	BHP	RPM	BHP	RPM	BHP	RPM	BHP	RPM	BHP	RPM	BHP	RPM	BHP	RPM	BHP
3000	2343	<b>3621</b>	<b>8.25</b>	<b>3763</b>	<b>9.17</b>	<b>3899</b>	<b>10.11</b>	<b>4031</b>	<b>11.07</b>								
3250	2539	<b>3656</b>	<b>8.66</b>	<b>3798</b>	<b>9.61</b>	<b>3934</b>	<b>10.58</b>	<b>4066</b>	<b>11.57</b>								
3500	2734	<b>3705</b>	<b>9.15</b>	<b>3833</b>	<b>10.06</b>	<b>3970</b>	<b>11.06</b>	<b>4101</b>	<b>12.08</b>	<b>4192</b>	<b>12.58</b>	<b>4315</b>	<b>13.62</b>	<i>4434</i>	<i>14.68</i>	<i>4584</i>	<i>16.39</i>
3750	2929	<b>3774</b>	<b>9.75</b>	<b>3896</b>	<b>10.67</b>	<b>4013</b>	<b>11.60</b>	<b>4136</b>	<b>12.61</b>	<b>4227</b>	<b>13.13</b>	<b>4350</b>	<b>14.19</b>	<i>4469</i>	<i>15.28</i>	<i>4619</i>	<i>17.04</i>
4000	3125	<b>3843</b>	<b>10.39</b>	<b>3965</b>	<b>11.34</b>	<b>4081</b>	<b>12.30</b>	<b>4194</b>	<b>13.29</b>	<b>4303</b>	<b>14.29</b>	<i>4420</i>	<i>15.39</i>	<i>4539</i>	<i>16.53</i>	<i>4654</i>	<i>17.70</i>
4250	3320	<b>3914</b>	<b>11.05</b>	<b>4035</b>	<b>12.04</b>	<b>4151</b>	<b>13.04</b>	<b>4263</b>	<b>14.06</b>	<i>4371</i>	<i>15.10</i>	<i>4476</i>	<i>16.15</i>	<i>4579</i>	<i>17.21</i>	<i>4690</i>	<i>18.38</i>
4500	3515	<b>3991</b>	<b>11.80</b>	<b>4105</b>	<b>12.78</b>	<b>4221</b>	<b>13.82</b>	<b>4332</b>	<b>14.87</b>	<i>4440</i>	<i>15.94</i>	<i>4545</i>	<i>17.02</i>	<i>4647</i>	<i>18.12</i>		
4750	3710	<b>4071</b>	<b>12.59</b>	<b>4184</b>	<b>13.61</b>	<b>4294</b>	<b>14.64</b>	<i>4403</i>	<i>15.72</i>	<i>4510</i>	<i>16.82</i>	<i>4615</i>	<i>17.94</i>				
5000	3906	<b>4151</b>	<b>13.43</b>	<b>4264</b>	<b>14.48</b>	<i>4373</i>	<i>15.55</i>	<i>4478</i>	<i>16.64</i>	<i>4581</i>	<i>17.74</i>	<i>4685</i>	<i>18.89</i>				
5250	4101	<b>4233</b>	<b>14.31</b>	<b>4345</b>	<b>15.40</b>	<i>4453</i>	<i>16.51</i>	<i>4558</i>	<i>17.63</i>	<i>4659</i>	<i>18.76</i>						
5500	4296	<b>4326</b>	<b>15.25</b>	<i>4427</i>	<i>16.37</i>	<i>4534</i>	<i>17.51</i>	<i>4638</i>	<i>18.67</i>								
5750	4492	<i>4426</i>	<i>16.27</i>	<i>4521</i>	<i>17.40</i>	<i>4616</i>	<i>18.56</i>										
6000	4684	<i>4528</i>	<i>17.33</i>	<i>4621</i>	<i>18.51</i>	<i>4712</i>	<i>19.70</i>										

Performance certified is for installation type B - Free inlet, Ducted Outlet. Performance ratings do not include the effects of appurtenances (accessories). Power rating (BHP) does not include transmission losses.

# HDBI-160

**WHEEL**  
Dia. - 16.50"

**OUTLET O.D.**  
Size - 12.50" x 18.38"  
Area - 1.54 Sq. Ft. I.D.

**INLET O.D.**  
Size - 18.00"  
Area - 1.73 Sq.Ft. I.D.

## BELT DRIVE RATING TABLES

Ratings at 70°F., .075 Density, Sea Level

All wheels are HDBI type  
Class II = light face above Class III  
**Class III = bold face**  
Class IV = italic face below Class III

SEE PAGE 24 FOR MAX. WHEEL RPM & WR<sup>2</sup>.

VOLUME CFM	O.V. FPM	0" SP		1/2" SP		1" SP		1 1/2" SP		2" SP		2 1/2" SP		3" SP		4" SP	
		RPM	BHP	RPM	BHP	RPM	BHP	RPM	BHP	RPM	BHP	RPM	BHP	RPM	BHP	RPM	BHP
2100	1363	865	.16	1054	.34	1214	.54	1361	.76	1498	.99	1622	1.24	1740	1.51	1975	2.14
2400	1558	988	.24	1155	.44	1306	.66	1435	.90	1566	1.15	1685	1.42	1798	1.70	2007	2.31
2700	1753	1112	.34	1259	.57	1401	.81	1526	1.07	1639	1.34	1755	1.62	1861	1.92	2061	2.55
3000	1948	1235	.47	1367	.72	1500	.99	1619	1.26	1726	1.55	1828	1.85	1932	2.17	2124	2.83
3300	2142	1359	.62	1481	.90	1601	1.19	1714	1.49	1818	1.80	1913	2.12	2005	2.45	2192	3.15
3600	2337	1482	.81	1596	1.11	1705	1.42	1812	1.74	1912	2.07	2005	2.41	2091	2.77	2264	3.50
3900	2532	1606	1.03	1711	1.35	1810	1.69	1913	2.03	2008	2.38	2098	2.75	2183	3.12	2338	3.89
4200	2727	1729	1.28	1828	1.63	1918	1.99	2016	2.36	2107	2.73	2194	3.12	2276	3.51	2428	4.32
4500	2922	1853	1.58	1946	1.95	2031	2.34	2120	2.73	2208	3.12	2291	3.53	2371	3.94	2519	4.80
4800	3116	1976	1.91	2064	2.31	2145	2.72	2225	3.14	2310	3.56	2391	3.98	2467	4.42	2613	5.32
5100	3311	2100	2.29	2183	2.72	2260	3.15	2332	3.59	2414	4.04	2492	4.49	2566	4.94	2707	5.88
5400	3506	2223	2.72	2302	3.17	2376	3.63	2445	4.09	2519	4.56	2595	5.03	2667	5.51	2803	6.49
5700	3701	2347	3.20	2422	3.67	2492	4.15	2559	4.64	2625	5.14	2698	5.64	2768	6.14	2900	7.16
6000	3896	2471	3.73	2542	4.23	2609	4.73	2673	5.25	2735	5.77	2803	6.29	2871	6.81	3000	7.88
6300	4090	2594	4.32	2662	4.84	2727	5.37	2788	5.91	2848	6.45	2909	7.00	2975	7.55	3101	8.66
6600	4285	2718	4.97	2783	5.51	2845	6.07	2904	6.63	2962	7.19	3017	7.77	3080	8.34	<b>3203</b>	<b>9.50</b>
6900	4480	2841	5.68	2903	6.25	2963	6.82	3021	7.41	3076	8.00	3130	8.60	3186	9.20	<b>3306</b>	<b>10.40</b>
7200	4675	2965	6.45	3024	7.04	3082	7.64	3137	8.25	3191	8.87	<b>3243</b>	<b>9.19</b>	<b>3294</b>	<b>10.12</b>	<b>3410</b>	<b>11.37</b>
7500	4870	3088	7.29	3146	7.91	<b>3201</b>	<b>8.53</b>	<b>3255</b>	<b>9.17</b>	<b>3307</b>	<b>9.80</b>	<b>3357</b>	<b>10.45</b>	<b>3406</b>	<b>11.10</b>	<b>3514</b>	<b>12.41</b>

VOLUME CFM	O.V. FPM	5" SP		6" SP		7" SP		8" SP		9" SP		10" SP		11" SP		12" SP	
		RPM	BHP	RPM	BHP	RPM	BHP	RPM	BHP	RPM	BHP	RPM	BHP	RPM	BHP	RPM	BHP
2100	1363	2183	2.81														
2400	1558	2214	3.02	2401	3.78												
2700	1753	2246	3.25	2433	4.04	2605	4.87	2765	5.73								
3000	1948	2301	3.55	2465	4.31	2637	5.17	2797	6.08	2947	7.02	3090	7.99				
3300	2142	2363	3.89	2523	4.68	2671	5.50	2828	6.43	2979	7.41	3121	8.42	<b>3257</b>	<b>9.45</b>	<b>3386</b>	<b>10.52</b>
3600	2337	2429	4.28	2586	5.10	2733	5.96	2870	6.85	3011	7.81	3153	8.86	<b>3288</b>	<b>9.93</b>	<b>3418</b>	<b>11.04</b>
3900	2532	2501	4.71	2651	5.55	2795	6.44	2932	7.37	3061	8.33	3185	9.31	<b>3320</b>	<b>10.42</b>	<b>3449</b>	<b>11.56</b>
4200	2727	2574	5.17	2722	6.06	2860	6.97	2995	7.93	3123	8.93	<b>3245</b>	<b>9.95</b>	<b>3361</b>	<b>10.99</b>	<b>3481</b>	<b>12.11</b>
4500	2922	2656	5.68	2795	6.60	2932	7.56	3060	8.54	3186	9.56	<b>3307</b>	<b>10.62</b>	<b>3423</b>	<b>11.71</b>	<b>3534</b>	<b>12.81</b>
4800	3116	2746	6.24	2870	7.19	3004	8.19	3132	9.21	<b>3252</b>	<b>10.25</b>	<b>3371</b>	<b>11.34</b>	<b>3486</b>	<b>12.46</b>	<b>3596</b>	<b>13.61</b>
5100	3311	2838	6.85	2960	7.84	3078	8.86	<b>3204</b>	<b>9.93</b>	<b>3324</b>	<b>11.01</b>	<b>3438</b>	<b>12.12</b>	<b>3549</b>	<b>13.26</b>	<b>3659</b>	<b>14.45</b>
5400	3506	2931	7.51	3052	8.54	3165	9.60	<b>3278</b>	<b>10.69</b>	<b>3396</b>	<b>11.82</b>	<b>3509</b>	<b>12.97</b>	<b>3618</b>	<b>14.13</b>	<b>3723</b>	<b>15.33</b>
5700	3701	3026	8.21	3144	9.29	<b>3256</b>	<b>10.40</b>	<b>3361</b>	<b>11.52</b>	<b>3470</b>	<b>12.68</b>	<b>3582</b>	<b>13.87</b>	<b>3689</b>	<b>15.08</b>	<b>3793</b>	<b>16.31</b>
6000	3896	3122	8.98	<b>3238</b>	<b>10.10</b>	<b>3347</b>	<b>11.24</b>	<b>3452</b>	<b>12.41</b>	<b>3552</b>	<b>13.60</b>	<b>3655</b>	<b>14.82</b>	<b>3762</b>	<b>16.07</b>	<b>3865</b>	<b>17.35</b>
6300	4090	<b>3219</b>	<b>9.80</b>	<b>3333</b>	<b>10.96</b>	<b>3441</b>	<b>12.15</b>	<b>3543</b>	<b>13.36</b>	<b>3642</b>	<b>14.59</b>	<b>3737</b>	<b>15.84</b>	<b>3835</b>	<b>17.12</b>	<b>3937</b>	<b>18.44</b>
6600	4285	<b>3318</b>	<b>10.68</b>	<b>3429</b>	<b>11.89</b>	<b>3535</b>	<b>13.12</b>	<b>3636</b>	<b>14.37</b>	<b>3733</b>	<b>15.64</b>	<b>3827</b>	<b>16.93</b>	<b>3917</b>	<b>18.24</b>	<i>4011</i>	<i>19.59</i>
6900	4480	<b>3419</b>	<b>11.63</b>	<b>3525</b>	<b>12.87</b>	<b>3630</b>	<b>14.15</b>	<b>3730</b>	<b>15.45</b>	<b>3826</b>	<b>16.76</b>	<b>3918</b>	<b>18.09</b>	<i>4007</i>	<i>19.45</i>	<i>4093</i>	<i>20.82</i>
7200	4675	<b>3520</b>	<b>12.64</b>	<b>3625</b>	<b>13.93</b>	<b>3726</b>	<b>15.25</b>	<b>3824</b>	<b>16.59</b>	<b>3919</b>	<b>17.94</b>	<i>4010</i>	<i>19.32</i>	<i>4098</i>	<i>20.71</i>	<i>4183</i>	<i>22.13</i>
7500	4870	<b>3622</b>	<b>13.72</b>	<b>3725</b>	<b>15.06</b>	<b>3824</b>	<b>16.41</b>	<b>3920</b>	<b>17.79</b>	<i>4013</i>	<i>19.20</i>	<i>4103</i>	<i>20.62</i>	<i>4190</i>	<i>22.05</i>	<i>4274</i>	<i>23.51</i>

VOLUME CFM	O.V. FPM	13" SP		14" SP		15" SP		16" SP		17" SP		18" SP		19" SP	
		RPM	BHP	RPM	BHP	RPM	BHP	RPM	BHP	RPM	BHP	RPM	BHP	RPM	BHP
3600	2337	<b>3542</b>	<b>12.17</b>	<b>3661</b>	<b>13.33</b>										
3900	2532	<b>3573</b>	<b>12.73</b>	<b>3693</b>	<b>13.93</b>	<b>3808</b>	<b>15.15</b>	<b>3919</b>	<b>16.40</b>						
4200	2727	<b>3605</b>	<b>13.31</b>	<b>3724</b>	<b>14.55</b>	<b>3839</b>	<b>15.81</b>	<b>3951</b>	<b>17.09</b>	4027	17.68				
4500	2922	<b>3640</b>	<b>13.94</b>	<b>3756</b>	<b>15.18</b>	<b>3871</b>	<b>16.47</b>	<i>3982</i>	<i>17.80</i>	4059	18.40	4164	19.74	4266	21.09
4800	3116	<b>3702</b>	<b>14.77</b>	<b>3804</b>	<b>15.96</b>	<b>3904</b>	<b>17.17</b>	4014	18.52	4122	19.90	4227	21.31		
5100	3311	<b>3764</b>	<b>15.65</b>	<b>3866</b>	<b>16.88</b>			4061	19.39	4154	20.68	4259	22.12		
5400	3506	<b>3828</b>	<b>16.58</b>	<b>3929</b>	<b>17.84</b>	4027	19.13	4123	20.44	4215	21.76				
5700	3701	<b>3892</b>	<b>17.55</b>	<i>3993</i>	<i>18.85</i>	4090	20.18	4185	21.53	4277	22.89				
6000	3896	<i>3964</i>	<i>18.63</i>	<i>4059</i>	<i>19.94</i>	4154	21.28	4248	22.67						
6300	4090	<i>4036</i>	<i>19.77</i>	<i>4131</i>	<i>21.12</i>	4223	22.48								
6600	4285	<i>4109</i>	<i>20.97</i>	<i>4203</i>	<i>22.36</i>										
6900	4480	<i>4182</i>	<i>22.22</i>	<i>4276</i>	<i>23.65</i>										

Performance certified is for installation type B - Free inlet, Ducted Outlet. Performance ratings do not include the effects of appurtenances (accessories). Power rating (BHP) does not include transmission losses.

# HDBI-180

**WHEEL**  
Dia. - 18.25"

**OUTLET O.D.**  
Size - 13.88" x 20.38"  
Area - 1.90 Sq. Ft. I.D.

**INLET O.D.**  
Size - 20.00"  
Area - 2.13 Sq.Ft. I.D.

## BELT DRIVE RATING TABLES

Ratings at 70°F., .075 Density, Sea Level

All wheels are HDBI type  
Class II = light face above Class III  
**Class III = bold face**  
Class IV = italic face below Class III

SEE PAGE 24 FOR MAX. WHEEL RPM & WR<sup>2</sup>.

VOLUME CFM	O.V. FPM	0" SP		1/2" SP		1" SP		1 1/2" SP		2" SP		2 1/2" SP		3" SP		4" SP	
		RPM	BHP	RPM	BHP	RPM	BHP	RPM	BHP	RPM	BHP	RPM	BHP	RPM	BHP	RPM	BHP
2800	1473	852	.28	1010	.54	1150	.82	1272	1.12	1392	1.46	1502	1.82	1605	2.18	1804	3.00
3200	1684	974	.42	1112	.70	1243	1.02	1356	1.35	1463	1.70	1568	2.09	1667	2.50	1848	3.33
3600	1894	1095	.60	1217	.91	1339	1.27	1447	1.62	1545	1.99	1640	2.39	1735	2.83	1910	3.74
4000	2105	1217	.82	1328	1.16	1439	1.55	1541	1.95	1635	2.35	1722	2.76	1806	3.20	1975	4.19
4400	2315	1339	1.09	1441	1.47	1540	1.88	1638	2.32	1728	2.76	1812	3.20	1890	3.65	2046	4.65
4800	2526	1461	1.42	1556	1.83	1644	2.26	1737	2.73	1823	3.22	1904	3.69	1980	4.17	2120	5.17
5200	2736	1582	1.80	1671	2.25	1751	2.70	1838	3.21	1920	3.73	1998	4.25	2072	4.76	2209	5.81
5600	2947	1704	2.25	1787	2.73	1863	3.22	1941	3.74	2020	4.29	2094	4.86	2166	5.42	2300	6.53
6000	3157	1826	2.77	1903	3.28	1975	3.80	2045	4.34	2121	4.93	2193	5.53	2261	6.14	2392	7.32
6400	3368	1947	3.36	2021	3.90	2089	4.46	2153	5.02	2224	5.63	2294	6.27	2360	6.91	2485	8.19
6800	3578	2069	4.03	2138	4.60	2203	5.19	2265	5.79	2328	6.42	2395	7.08	2459	7.76	2580	9.13
7200	3789	2191	4.78	2256	5.39	2318	6.01	2377	6.64	2434	7.28	2498	7.98	2560	8.69	2678	10.14
7600	4000	2313	5.62	2375	6.27	2434	6.92	2490	7.58	2545	8.25	2602	8.96	2662	9.70	2777	11.22
8000	4210	2434	6.56	2494	7.23	2550	7.92	2604	8.62	2657	9.32	2707	10.03	2766	10.81	2877	12.39
8400	4421	2556	7.59	2613	8.30	2667	9.02	2719	9.75	2769	10.49	2818	11.23	2870	12.01	<b>2978</b>	<b>13.66</b>
8800	4631	2678	8.73	2732	9.47	2784	10.22	2834	10.99	2883	11.75	<b>2930</b>	<b>12.53</b>	<b>2975</b>	<b>13.31</b>	<b>3080</b>	<b>15.03</b>
9200	4842	2800	9.98	2851	10.75	2901	11.54	<b>2950</b>	<b>12.33</b>	<b>2997</b>	<b>13.13</b>	<b>3042</b>	<b>13.94</b>	<b>3086</b>	<b>14.75</b>	<b>3184</b>	<b>16.50</b>

NOTE: See pages 27, 29 or 30 for minimum

VOLUME CFM	O.V. FPM	5" SP		6" SP		7" SP		8" SP		9" SP		10" SP		11" SP		12" SP	
		RPM	BHP	RPM	BHP	RPM	BHP	RPM	BHP	RPM	BHP	RPM	BHP	RPM	BHP	RPM	BHP
3200	1684	2022	4.26	2192	5.28	2347	6.36										
3600	1894	2069	4.68	2223	5.69	2378	6.83	2523	8.01	2659	9.23						
4000	2105	2131	5.20	2275	6.23	2410	7.31	2554	8.55	2690	9.83	2819	11.15	<b>2942</b>	<b>12.51</b>	<b>3059</b>	<b>13.91</b>
4400	2315	2196	5.75	2337	6.86	2470	8.00	2594	9.17	2722	10.45	2850	11.82	<b>2973</b>	<b>13.24</b>	<b>3090</b>	<b>14.69</b>
4800	2526	2266	6.32	2402	7.53	2532	8.74	2655	9.97	2772	11.23	2882	12.52	<b>3004</b>	<b>13.99</b>	<b>3121</b>	<b>15.50</b>
5200	2736	2339	6.94	2472	8.20	2597	9.51	2717	10.83	2833	12.15	<b>2943</b>	<b>13.51</b>	<b>3048</b>	<b>14.89</b>	<b>3152</b>	<b>16.33</b>
5600	2947	2422	7.68	2544	8.93	2668	10.30	2783	11.71	2896	13.13	<b>3005</b>	<b>14.55</b>	<b>3109</b>	<b>15.99</b>	<b>3209</b>	<b>17.46</b>
6000	3157	2512	8.53	2623	9.77	2739	11.15	2854	12.62	<b>2963</b>	<b>14.13</b>	<b>3067</b>	<b>15.65</b>	<b>3171</b>	<b>17.16</b>	<b>3271</b>	<b>18.69</b>
6400	3368	2603	9.46	2713	10.76	2816	12.09	<b>2926</b>	<b>13.59</b>	<b>3034</b>	<b>15.15</b>	<b>3136</b>	<b>16.75</b>	<b>3235</b>	<b>18.39</b>	<b>3333</b>	<b>19.99</b>
6800	3578	2695	10.47	2803	11.84	<b>2905</b>	<b>13.23</b>	<b>3001</b>	<b>14.65</b>	<b>3106</b>	<b>16.25</b>	<b>3207</b>	<b>17.91</b>	<b>3305</b>	<b>19.60</b>	<b>3399</b>	<b>21.33</b>
7200	3789	2789	11.57	2895	13.00	<b>2995</b>	<b>14.45</b>	<b>3090</b>	<b>15.93</b>	<b>3180</b>	<b>17.43</b>	<b>3279</b>	<b>19.13</b>	<b>3376</b>	<b>20.88</b>	<b>3469</b>	<b>22.67</b>
7600	4000	2884	12.76	<b>2988</b>	<b>14.25</b>	<b>3086</b>	<b>15.76</b>	<b>3179</b>	<b>17.31</b>	<b>3269</b>	<b>18.87</b>	<b>3355</b>	<b>20.46</b>	<b>3448</b>	<b>22.24</b>	<b>3541</b>	<b>24.08</b>
8000	4210	<b>2982</b>	<b>14.01</b>	<b>3082</b>	<b>15.60</b>	<b>3178</b>	<b>17.18</b>	<b>3270</b>	<b>18.78</b>	<b>3358</b>	<b>20.41</b>	<b>3443</b>	<b>22.05</b>	<b>3525</b>	<b>23.73</b>	<i>3613</i>	<i>25.57</i>
8400	4421	<b>3081</b>	<b>15.34</b>	<b>3177</b>	<b>17.05</b>	<b>3272</b>	<b>18.69</b>	<b>3363</b>	<b>20.36</b>	<b>3449</b>	<b>22.05</b>	<b>3533</b>	<b>23.76</b>	<i>3613</i>	<i>25.49</i>	<i>3691</i>	<i>27.24</i>
8800	4631	<b>3180</b>	<b>16.77</b>	<b>3275</b>	<b>18.55</b>	<b>3367</b>	<b>20.31</b>	<b>3456</b>	<b>22.04</b>	<b>3541</b>	<b>23.79</b>	<i>3623</i>	<i>25.57</i>	<i>3703</i>	<i>27.36</i>	<i>3780</i>	<i>29.17</i>
9200	4842	<b>3281</b>	<b>18.31</b>	<b>3374</b>	<b>20.16</b>	<b>3463</b>	<b>22.03</b>	<b>3550</b>	<b>23.84</b>	<i>3634</i>	<i>25.65</i>	<i>3715</i>	<i>27.49</i>	<i>3794</i>	<i>29.34</i>	<i>3870</i>	<i>31.22</i>

VOLUME CFM	O.V. FPM	13" SP		14" SP		15" SP		16" SP		17" SP		18" SP		19" SP	
		RPM	BHP	RPM	BHP	RPM	BHP	RPM	BHP	RPM	BHP	RPM	BHP	RPM	BHP
4400	2315	<b>3202</b>	<b>16.19</b>	<b>3310</b>	<b>17.71</b>										
4800	2526	<b>3233</b>	<b>17.05</b>	<b>3341</b>	<b>18.63</b>	<b>3445</b>	<b>20.24</b>	<b>3546</b>	<b>21.89</b>	<i>3644</i>	<i>23.57</i>				
5200	2736	<b>3264</b>	<b>17.93</b>	<b>3372</b>	<b>19.57</b>	<b>3476</b>	<b>21.24</b>	<b>3577</b>	<b>22.94</b>	<i>3674</i>	<i>24.67</i>	<i>3769</i>	<i>26.44</i>	<i>3862</i>	<i>28.23</i>
5600	2947	<b>3306</b>	<b>18.96</b>	<b>3403</b>	<b>20.54</b>	<b>3507</b>	<b>22.26</b>	<i>3608</i>	<i>24.02</i>	<i>3706</i>	<i>25.81</i>	<i>3800</i>	<i>27.63</i>		
6000	3157	<b>3367</b>	<b>20.25</b>	<b>3459</b>	<b>21.84</b>	<b>3548</b>	<b>23.45</b>	<i>3639</i>	<i>25.13</i>	<i>3737</i>	<i>26.98</i>	<i>3832</i>	<i>28.85</i>		
6400	3368	<b>3428</b>	<b>21.62</b>	<b>3520</b>	<b>23.26</b>	<i>3609</i>	<i>24.93</i>	<i>3696</i>	<i>26.62</i>	<i>3780</i>	<i>28.34</i>	<i>3863</i>	<i>30.11</i>		
6800	3578	<b>3491</b>	<b>23.05</b>	<b>3583</b>	<b>24.76</b>	<i>3671</i>	<i>26.49</i>	<i>3757</i>	<i>28.25</i>	<i>3840</i>	<i>30.02</i>				
7200	3789	<b>3559</b>	<b>24.48</b>	<i>3646</i>	<i>26.33</i>	<i>3734</i>	<i>28.13</i>	<i>3819</i>	<i>29.95</i>						
7600	4000	<i>3630</i>	<i>25.96</i>	<i>3716</i>	<i>27.86</i>	<i>3799</i>	<i>29.79</i>	<i>3882</i>	<i>31.73</i>						
8000	4210	<i>3701</i>	<i>27.51</i>	<i>3787</i>	<i>29.47</i>	<i>3870</i>	<i>31.47</i>								
8400	4421	<i>3774</i>	<i>29.14</i>	<i>3859</i>	<i>31.17</i>										
8800	4631	<i>3855</i>	<i>31.01</i>												

Performance certified is for installation type B - Free inlet, Ducted Outlet. Performance ratings do not include the effects of appurtenances (accessories). Power rating (BHP) does not include transmission losses.

# HDBI-200

**WHEEL**  
Dia. - 20.00"

**OUTLET O.D.**  
Size - 15.25" x 22.38"  
Area - 2.30 Sq. Ft. I.D.

**INLET O.D.**  
Size - .22"  
Area - 2.58 Sq.Ft. I.D.

## BELT DRIVE RATING TABLES

Ratings at 70°F., .075 Density, Sea Level

All wheels are HDBI type  
Class II = light face above Class III  
**Class III = bold face**  
Class IV = italic face below Class III

SEE PAGE 24 FOR MAX. WHEEL RPM & WR<sup>2</sup>.

VOLUME CFM	O.V. FPM	0" SP		1/2" SP		1" SP		1 1/2" SP		2" SP		2 1/2" SP		3" SP		4" SP	
		RPM	BHP	RPM	BHP	RPM	BHP	RPM	BHP	RPM	BHP	RPM	BHP	RPM	BHP	RPM	BHP
4200	1826	971	.59	1085	.95	1199	1.32	1299	1.71	1389	2.12	1479	2.56	1566	3.01	1728	3.97
4600	2000	1064	.78	1169	1.17	1274	1.57	1370	1.99	1457	2.43	1537	2.88	1620	3.36	1775	4.35
5000	2173	1156	1.00	1254	1.42	1350	1.86	1442	2.31	1526	2.77	1604	3.25	1677	3.75	1829	4.80
5400	2347	1249	1.26	1340	1.71	1428	2.18	1516	2.66	1597	3.16	1673	3.67	1744	4.19	1883	5.28
5800	2521	1341	1.56	1427	2.05	1507	2.55	1592	3.06	1670	3.58	1744	4.12	1813	4.67	1941	5.81
6200	2695	1433	1.91	1515	2.43	1588	2.96	1669	3.50	1744	4.05	1815	4.62	1883	5.20	2008	6.40
6600	2869	1526	2.30	1603	2.85	1673	3.42	1746	3.99	1819	4.57	1888	5.17	1954	5.78	2077	7.03
7000	3043	1618	2.75	1691	3.33	1758	3.93	1825	4.53	1896	5.15	1963	5.77	2026	6.41	2146	7.72
7400	3217	1711	3.25	1780	3.86	1844	4.49	1905	5.13	1973	5.77	2038	6.43	2100	7.09	2217	8.46
7800	3391	1803	3.80	1869	4.45	1931	5.11	1989	5.78	2052	6.46	2115	7.14	2175	7.84	2288	9.26
8200	3565	1896	4.42	1959	5.09	2018	5.79	2074	6.49	2131	7.21	2192	7.92	2251	8.64	2361	10.12
8600	3739	1988	5.09	2048	5.80	2105	6.53	2159	7.26	2211	8.01	2270	8.76	2327	9.51	2435	11.05
9000	3913	2081	5.84	2138	6.58	2193	7.34	2245	8.10	2295	8.89	2349	9.67	2405	10.45	2510	12.05
9400	4086	2173	6.65	2229	7.43	2281	8.21	2331	9.01	2380	9.83	2428	10.65	2483	11.46	2586	13.12
9800	4260	2266	7.54	2319	8.34	2370	9.16	2418	10.00	2465	10.84	2511	11.69	2561	12.54	<b>2662</b>	<b>14.26</b>
10200	4434	2358	8.50	2409	9.34	2458	10.19	2505	11.05	2551	11.93	2595	12.81	2641	13.70	<b>2739</b>	<b>15.48</b>
10600	4608	2451	9.54	2500	10.41	2547	11.29	2593	12.19	2637	13.09	<b>2680</b>	<b>14.01</b>	<b>2722</b>	<b>14.94</b>	<b>2817</b>	<b>16.78</b>
11000	4782	2543	10.66	2591	11.56	2637	12.48	<b>2681</b>	<b>13.41</b>	<b>2724</b>	<b>14.34</b>	<b>2765</b>	<b>15.29</b>	<b>2806</b>	<b>16.25</b>	<b>2895</b>	<b>18.16</b>
11400	4956	2636	11.87	<b>2682</b>	<b>12.80</b>	<b>2726</b>	<b>13.75</b>	<b>2769</b>	<b>14.71</b>	<b>2811</b>	<b>15.68</b>	<b>2851</b>	<b>16.65</b>	<b>2891</b>	<b>17.64</b>	<b>2974</b>	<b>19.63</b>

**NOTE:** See pages 27, 29 or 30 for minimum motor frame sizes regardless of BHP.

VOLUME CFM	O.V. FPM	5" SP		6" SP		7" SP		8" SP		9" SP		10" SP		11" SP		12" SP	
		RPM	BHP	RPM	BHP	RPM	BHP	RPM	BHP	RPM	BHP	RPM	BHP	RPM	BHP	RPM	BHP
4200	1826	1874	4.99	2021	6.14	2163	7.39	2295	8.69	2420	10.05						
4600	2000	1921	5.43	2053	6.56	2187	7.81	2319	9.16	2443	10.56	2560	12.01	<b>2672</b>	<b>13.51</b>		
5000	2173	1968	5.91	2099	7.09	2221	8.31	2343	9.64	2467	11.09	2584	12.59	<b>2696</b>	<b>14.13</b>	<b>2803</b>	<b>15.72</b>
5400	2347	2019	6.44	2146	7.65	2267	8.93	2381	10.25	2490	11.63	2608	13.18	<b>2719</b>	<b>14.77</b>	<b>2826</b>	<b>16.41</b>
5800	2521	2073	7.02	2196	8.27	2315	9.59	2427	10.96	2533	12.37	2634	13.82	<b>2743</b>	<b>15.43</b>	<b>2850</b>	<b>17.12</b>
6200	2695	2128	7.64	2250	8.95	2364	10.29	2474	11.71	2580	13.18	<b>2680</b>	<b>14.68</b>	<b>2776</b>	<b>16.21</b>	<b>2874</b>	<b>17.84</b>
6600	2869	2189	8.32	2304	9.68	2417	11.08	2523	12.51	2627	14.03	<b>2727</b>	<b>15.58</b>	<b>2823</b>	<b>17.17</b>	<b>2914</b>	<b>18.79</b>
7000	3043	2257	9.07	2360	10.46	2471	11.92	2577	13.41	<b>2676</b>	<b>14.93</b>	<b>2774</b>	<b>16.53</b>	<b>2869</b>	<b>18.17</b>	<b>2960</b>	<b>19.85</b>
7400	3217	2325	9.87	2427	11.31	2526	12.81	2631	14.36	<b>2729</b>	<b>15.94</b>	<b>2824</b>	<b>17.55</b>	<b>2917</b>	<b>19.23</b>	<b>3007</b>	<b>20.96</b>
7800	3391	2395	10.73	2495	12.23	2588	13.77	<b>2685</b>	<b>15.36</b>	<b>2784</b>	<b>17.00</b>	<b>2877</b>	<b>18.67</b>	<b>2967</b>	<b>20.36</b>	<b>3055</b>	<b>22.12</b>
8200	3565	2465	11.65	2563	13.21	2656	14.80	<b>2744</b>	<b>16.43</b>	<b>2838</b>	<b>18.12</b>	<b>2931</b>	<b>19.84</b>	<b>3020</b>	<b>21.59</b>	<b>3106</b>	<b>23.37</b>
8600	3739	2537	12.63	2633	14.25	<b>2724</b>	<b>15.90</b>	<b>2811</b>	<b>17.58</b>	<b>2894</b>	<b>19.30</b>	<b>2986</b>	<b>21.08</b>	<b>3074</b>	<b>22.89</b>	<b>3159</b>	<b>24.73</b>
9000	3913	2609	13.68	<b>2704</b>	<b>15.36</b>	<b>2794</b>	<b>17.07</b>	<b>2879</b>	<b>18.81</b>	<b>2961</b>	<b>20.58</b>	<b>3041</b>	<b>22.38</b>	<b>3129</b>	<b>24.25</b>	<b>3213</b>	<b>26.15</b>
9400	4086	<b>2682</b>	<b>14.81</b>	<b>2775</b>	<b>16.54</b>	<b>2864</b>	<b>18.31</b>	<b>2948</b>	<b>20.10</b>	<b>3029</b>	<b>21.93</b>	<b>3107</b>	<b>23.78</b>	<b>3184</b>	<b>25.68</b>	<b>3268</b>	<b>27.63</b>
9800	4260	<b>2757</b>	<b>16.01</b>	<b>2847</b>	<b>17.79</b>	<b>2934</b>	<b>19.62</b>	<b>3018</b>	<b>21.47</b>	<b>3098</b>	<b>23.36</b>	<b>3174</b>	<b>25.27</b>	<b>3248</b>	<b>27.21</b>	<i>3323</i>	<i>29.19</i>
10200	4434	<b>2832</b>	<b>17.29</b>	<b>2920</b>	<b>19.13</b>	<b>3006</b>	<b>21.01</b>	<b>3088</b>	<b>22.92</b>	<b>3167</b>	<b>24.86</b>	<b>3243</b>	<b>26.83</b>			<i>3387</i>	<i>30.85</i>
10600	4608	<b>2908</b>	<b>18.65</b>	<b>2994</b>	<b>20.54</b>	<b>3078</b>	<b>22.48</b>	<b>3159</b>	<b>24.45</b>	<b>3237</b>	<b>26.45</b>	<i>3312</i>	<i>28.47</i>	<i>3384</i>	<i>30.52</i>	<i>3454</i>	<i>32.60</i>
11000	4782	<b>2985</b>	<b>20.09</b>	<b>3070</b>	<b>22.05</b>	<b>3151</b>	<b>24.03</b>	<b>3230</b>	<b>26.06</b>	<i>3307</i>	<i>28.12</i>	<i>3381</i>	<i>30.20</i>	<i>3453</i>	<i>32.31</i>	<i>3523</i>	<i>34.44</i>
11400	4956	<b>3062</b>	<b>21.62</b>	<b>3145</b>	<b>23.64</b>	<b>3225</b>	<b>25.68</b>	<i>3303</i>	<i>27.76</i>	<i>3379</i>	<i>29.87</i>	<i>3452</i>	<i>32.01</i>	<i>3523</i>	<i>34.18</i>	<i>3591</i>	<i>36.37</i>

VOLUME CFM	O.V. FPM	13" SP		14" SP		15" SP		16" SP		17" SP		18" SP		19" SP	
		RPM	BHP	RPM	BHP	RPM	BHP	RPM	BHP	RPM	BHP	RPM	BHP	RPM	BHP
5400	2347	<b>2928</b>	<b>18.09</b>	<b>3027</b>	<b>19.81</b>	<b>3122</b>	<b>21.57</b>								
5800	2521	<b>2952</b>	<b>18.84</b>	<b>3051</b>	<b>20.61</b>	<b>3146</b>	<b>22.42</b>	<b>3238</b>	<b>24.27</b>	3327	26.15				
6200	2695	<b>2976</b>	<b>19.62</b>	<b>3074</b>	<b>21.43</b>	<b>3169</b>	<b>23.29</b>	<b>3261</b>	<b>25.18</b>	3350	27.11	3437	29.08	3521	31.08
6600	2869	<b>3002</b>	<b>20.44</b>	<b>3098</b>	<b>22.28</b>	<b>3193</b>	<b>24.18</b>	<b>3285</b>	<b>26.12</b>	3374	28.10	3460	30.11	3545	32.16
7000	3043	<b>3048</b>	<b>21.56</b>	<b>3133</b>	<b>23.29</b>	<b>3217</b>	<b>25.09</b>	<i>3309</i>	<i>27.08</i>	3398	29.11	3484	31.17	3568	33.26
7400	3217	<b>3095</b>	<b>22.72</b>	<b>3179</b>	<b>24.51</b>	<b>3260</b>	<b>26.33</b>	<i>3339</i>	<i>28.17</i>	3421	30.14	3508	32.25		
7800	3391	<b>3142</b>	<b>23.93</b>	<b>3226</b>	<b>25.78</b>	<i>3307</i>	<i>27.65</i>	<i>3385</i>	<i>29.55</i>	3462	31.48	3536	33.43		
8200	3565	<b>3189</b>	<b>25.20</b>	<b>3273</b>	<b>27.10</b>	<i>3354</i>	<i>29.03</i>	<i>3432</i>	<i>30.99</i>	3508	32.97				
8600	3739	<b>3241</b>	<b>26.59</b>	<i>3321</i>	<i>28.48</i>	3401	30.47	3479	32.48	3555	34.51				
9000	3913	<i>3295</i>	<i>28.07</i>	<i>3374</i>	<i>30.01</i>	3450	31.98	<i>3527</i>	<i>34.03</i>						
9400	4086	<i>3349</i>	<i>29.61</i>	<i>3427</i>	<i>31.61</i>	3503	33.64								
9800	4260	<i>3404</i>	<i>31.22</i>	<i>3482</i>	<i>33.28</i>	3557	35.37								

Performance certified is for installation type B - Free inlet, Ducted Outlet. Performance ratings do not include the effects of appurtenances (accessories). Power rating (BHP) does not include transmission losses.

# HDBI-220

**WHEEL**  
Dia. - 22.25"

**OUTLET O.D.**  
Size - 16.88" x 24.88"  
Area - 2.84 Sq. Ft. I.D.

**INLET O.D.**  
Size - 24.63"  
Area - 3.24 Sq.Ft. I.D.

## BELT DRIVE RATING TABLES

Ratings at 70°F., .075 Density, Sea Level

SEE PAGE 24 FOR MAX. WHEEL RPM & WR<sup>2</sup>.

All wheels are HDBI type  
Class II = light face above Class III  
**Class III = bold face**  
Class IV = italic face below Class III

VOLUME CFM	O.V. FPM	0" SP		1/2" SP		1" SP		1 1/2" SP		2" SP		2 1/2" SP		3" SP		4" SP	
		RPM	BHP	RPM	BHP	RPM	BHP	RPM	BHP	RPM	BHP	RPM	BHP	RPM	BHP	RPM	BHP
4600	1619	765	.48	870	.85	962	1.22	1054	1.62	1137	2.04	1214	2.48	1299	2.99	1460	4.10
5200	1830	865	.70	959	1.11	1042	1.52	1125	1.96	1204	2.41	1277	2.89	1347	3.38	1494	4.52
5800	2042	965	.97	1051	1.43	1128	1.88	1199	2.35	1275	2.85	1345	3.36	1411	3.89	1534	4.99
6400	2253	1065	1.31	1144	1.80	1215	2.31	1281	2.82	1348	3.35	1415	3.90	1479	4.47	1597	5.64
7000	2464	1164	1.71	1237	2.25	1303	2.82	1366	3.36	1424	3.92	1488	4.51	1549	5.12	1662	6.37
7600	2676	1264	2.19	1332	2.77	1394	3.39	1453	3.98	1509	4.58	1561	5.19	1621	5.84	1732	7.17
8200	2887	1364	2.75	1427	3.38	1486	4.03	1541	4.69	1594	5.33	1645	5.98	1695	6.65	1803	8.06
8800	3098	1464	3.39	1523	4.07	1578	4.77	1630	5.48	1681	6.17	1730	6.86	1776	7.56	1875	9.03
9400	3309	1564	4.14	1619	4.86	1672	5.60	1721	6.36	1769	7.10	1816	7.83	1861	8.58	1949	10.11
10000	3521	1663	4.98	1716	5.75	1766	6.53	1813	7.34	1858	8.15	1903	8.92	1947	9.70	2029	11.30
10600	3732	1763	5.93	1813	6.75	1860	7.57	1906	8.42	1949	9.28	1991	10.12	2033	10.94	2113	12.61
11200	3943	1863	7.00	1910	7.85	1956	8.73	1999	9.62	2040	10.52	2080	11.43	2121	12.29	2198	14.05
11800	4154	1963	8.19	2008	9.09	2051	10.01	2092	10.94	2132	11.88	2171	12.84	2209	13.78	2284	15.61
12400	4366	2063	9.50	2106	10.44	2147	11.41	2187	12.38	2225	13.37	2262	14.37	2298	15.39	<b>2371</b>	<b>17.30</b>
13000	4577	2163	10.94	2204	11.93	2243	12.95	2281	13.96	<b>2318</b>	<b>15.00</b>	<b>2354</b>	<b>16.04</b>	<b>2389</b>	<b>17.10</b>	<b>2459</b>	<b>19.14</b>
13600	4788	2262	12.53	2302	13.57	<b>2340</b>	<b>14.62</b>	<b>2376</b>	<b>15.68</b>	<b>2412</b>	<b>16.76</b>	<b>2447</b>	<b>17.85</b>	<b>2481</b>	<b>18.95</b>	<b>2547</b>	<b>21.12</b>

**NOTE:** See pages 27, 29 or 30 for minimum motor frame sizes regardless of BHP.

VOLUME CFM	O.V. FPM	5" SP		6" SP		7" SP		8" SP		9" SP		10" SP		11" SP		12" SP	
		RPM	BHP	RPM	BHP	RPM	BHP	RPM	BHP	RPM	BHP	RPM	BHP	RPM	BHP	RPM	BHP
4600	1619	1629	5.38	1782	6.74	1922	8.17										
5200	1830	1635	5.78	1785	7.20	1926	8.70	2056	10.27	2179	11.90	2296	13.58				
5800	2042	1669	6.30	1797	7.70	1929	9.24	2060	10.88	2183	12.58	2299	14.34	<b>2410</b>	<b>16.15</b>	<b>2515</b>	<b>18.01</b>
6400	2253	1706	6.87	1831	8.33	1948	9.87	2064	11.49	2186	13.27	2303	15.10	<b>2413</b>	<b>16.98</b>	<b>2519</b>	<b>18.91</b>
7000	2464	1769	7.67	1868	9.02	1983	10.61	2092	12.28	2195	13.99	<b>2306</b>	<b>15.86</b>	<b>2417</b>	<b>17.82</b>	<b>2522</b>	<b>19.83</b>
7600	2676	1833	8.54	1930	9.97	2021	11.43	2127	13.14	2229	14.93	<b>2326</b>	<b>16.76</b>	<b>2420</b>	<b>18.66</b>	<b>2526</b>	<b>20.74</b>
8200	2887	1902	9.51	1994	11.00	2084	12.54	2169	14.12	2264	15.91	<b>2360</b>	<b>17.82</b>	<b>2453</b>	<b>19.78</b>	<b>2541</b>	<b>21.78</b>
8800	3098	1972	10.56	2062	12.13	2148	13.75	2232	15.40	<b>2311</b>	<b>17.09</b>	<b>2395</b>	<b>18.92</b>	<b>2487</b>	<b>20.96</b>	<b>2575</b>	<b>23.03</b>
9400	3309	2044	11.72	2132	13.36	2215	15.05	2296	16.78	<b>2374</b>	<b>18.54</b>	<b>2449</b>	<b>20.34</b>	<b>2522</b>	<b>22.19</b>	<b>2610</b>	<b>24.34</b>
10000	3521	2116	12.97	2203	14.70	2285	16.46	<b>2362</b>	<b>18.26</b>	<b>2438</b>	<b>20.10</b>	<b>2512</b>	<b>21.97</b>	<b>2583</b>	<b>23.87</b>	<b>2652</b>	<b>25.81</b>
10600	3732	2190	14.34	2275	16.15	<b>2356</b>	<b>17.99</b>	<b>2432</b>	<b>19.86</b>	<b>2505</b>	<b>21.77</b>	<b>2576</b>	<b>23.71</b>	<b>2647</b>	<b>25.70</b>	<b>2714</b>	<b>27.70</b>
11200	3943	2271	15.84	<b>2348</b>	<b>17.71</b>	<b>2427</b>	<b>19.63</b>	<b>2503</b>	<b>21.58</b>	<b>2575</b>	<b>23.57</b>	<b>2644</b>	<b>25.58</b>	<b>2711</b>	<b>27.63</b>	<b>2778</b>	<b>29.72</b>
11800	4154	<b>2355</b>	<b>17.48</b>	<b>2422</b>	<b>19.39</b>	<b>2500</b>	<b>21.39</b>	<b>2574</b>	<b>23.42</b>	<b>2645</b>	<b>25.49</b>	<b>2713</b>	<b>27.58</b>	<b>2779</b>	<b>29.70</b>	<i>2843</i>	<i>31.86</i>
12400	4366	<b>2440</b>	<b>19.25</b>	<b>2506</b>	<b>21.24</b>	<b>2574</b>	<b>23.28</b>	<b>2646</b>	<b>25.40</b>	<b>2716</b>	<b>27.54</b>	<b>2784</b>	<b>29.71</b>	<i>2848</i>	<i>31.91</i>	<i>2911</i>	<i>34.14</i>
13000	4577	<b>2526</b>	<b>21.17</b>	<b>2590</b>	<b>23.23</b>	<b>2652</b>	<b>25.33</b>	<b>2720</b>	<b>27.50</b>	<b>2789</b>	<b>29.73</b>	<i>2855</i>	<i>31.98</i>	<i>2919</i>	<i>34.26</i>	<i>2981</i>	<i>36.56</i>
13600	4788	<b>2613</b>	<b>23.23</b>	<b>2675</b>	<b>25.37</b>	<b>2735</b>	<b>27.54</b>	<b>2794</b>	<b>29.75</b>	<i>2862</i>	<i>32.06</i>	<i>2927</i>	<i>34.39</i>	<i>2990</i>	<i>36.75</i>	<i>3051</i>	<i>39.13</i>

VOLUME CFM	O.V. FPM	13" SP		14" SP		15" SP		16" SP		17" SP		18" SP		19" SP		20" SP	
		RPM	BHP	RPM	BHP	RPM	BHP	RPM	BHP	RPM	BHP	RPM	BHP	RPM	BHP	RPM	BHP
6400	2253	<b>2620</b>	<b>20.90</b>	<b>2718</b>	<b>22.93</b>	<b>2812</b>	<b>25.01</b>										
7000	2464	<b>2624</b>	<b>21.88</b>	<b>2721</b>	<b>23.99</b>	<b>2815</b>	<b>26.14</b>	2906	28.33	2994	30.57	3080	32.85				
7600	2676	<b>2627</b>	<b>22.88</b>	<b>2725</b>	<b>25.05</b>	<b>2819</b>	<b>27.28</b>	2910	29.55	2998	31.86	3084	34.21	3167	36.60	3248	39.03
8200	2887	<b>2631</b>	<b>23.87</b>	<b>2728</b>	<b>26.13</b>	<b>2822</b>	<b>28.42</b>	2913	30.76	3001	33.15	3087	35.57	3170	38.04	3251	40.54
8800	3098	<b>2660</b>	<b>25.15</b>	<b>2741</b>	<b>27.31</b>	2826	29.57	2917	31.99	3005	34.45	3091	36.94	3174	39.48	3255	42.06
9400	3309	<b>2694</b>	<b>26.53</b>	<b>2775</b>	<b>28.76</b>	2854	31.03	2930	33.34	3008	35.75	3094	38.32	3177	40.93	3258	43.59
10000	3521	<b>2729</b>	<b>27.97</b>	<b>2810</b>	<b>30.28</b>	2888	32.62	2964	35.00	3038	37.42	3109	39.88	3181	42.39	3262	45.12
10600	3732	<b>2780</b>	<b>29.74</b>	2845	31.85	2923	34.27	2999	36.72	3072	39.22	3144	41.75	3213	44.31	3281	46.90
11200	3943	<i>2843</i>	<i>31.83</i>	2906	33.98	2967	36.14	3034	38.51	3107	41.08	3178	43.68	3248	46.32	3315	48.99
11800	4154	<i>2907</i>	<i>34.05</i>	2969	36.27	3029	38.51	3088	40.78	3145	43.07	3213	45.68	3282	48.39	3350	51.14
12400	4366	<i>2972</i>	<i>36.40</i>	3033	38.69	3093	41.01	3151	43.36	3208	45.73	3263	48.12	3318	50.54	3385	53.36
13000	4577	<i>3041</i>	<i>38.90</i>	3099	41.25	3157	43.65	3215	46.07	3271	48.51	3326	50.98	3380	53.48	3433	55.99
13600	4788	<i>3110</i>	<i>41.54</i>	3168	43.98	3224	46.44	3280	48.92	3335	51.45	3390	53.99	3443	56.56		

Performance certified is for installation type B - Free inlet, Ducted Outlet. Performance ratings do not include the effects of appurtenances (accessories). Power rating (BHP) does not include transmission losses.

# HDBI-240

**WHEEL**  
Dia. - 24.50"

**OUTLET O.D.**  
Size - 18.56" x 27.38"  
Area - 3.45 Sq. Ft. I.D.

**INLET O.D.**  
Size - 27.00"  
Area - 3.90 Sq.Ft. I.D.

## BELT DRIVE RATING TABLES

Ratings at 70°F., .075 Density, Sea Level

All wheels are HDBI type  
Class II = light face above Class III  
**Class III = bold face**  
Class IV = italic face below Class III

SEE PAGE 24 FOR MAX. WHEEL RPM & WR<sup>2</sup>.

VOLUME CFM	O.V. FPM	0" SP		1/4" SP		1/2" SP		3/4" SP		1" SP		1 1/2" SP		2" SP		2 1/2" SP	
		RPM	BHP	RPM	BHP	RPM	BHP	RPM	BHP	RPM	BHP	RPM	BHP	RPM	BHP	RPM	BHP
5000	1449	623	.42	678	.62	727	.82	772	1.02	821	1.23	908	1.68	987	2.16	1073	2.71
5800	1681	723	.66	771	.89	814	1.12	856	1.34	894	1.58	977	2.08	1051	2.60	1120	3.15
6600	1913	822	.97	865	1.23	905	1.49	942	1.75	978	2.01	1049	2.56	1120	3.13	1184	3.73
7400	2144	922	1.37	961	1.66	997	1.95	1030	2.25	1064	2.54	1125	3.12	1191	3.75	1254	4.40
8200	2376	1022	1.87	1057	2.18	1090	2.51	1121	2.83	1152	3.16	1210	3.80	1264	4.46	1325	5.16
9000	2608	1121	2.47	1154	2.81	1184	3.17	1213	3.52	1241	3.89	1296	4.59	1347	5.30	1398	6.04
9800	2840	1221	3.19	1251	3.56	1279	3.95	1307	4.33	1333	4.73	1384	5.50	1433	6.27	1479	7.05
10600	3072	1321	4.04	1348	4.44	1375	4.85	1400	5.27	1425	5.69	1472	6.55	1519	7.37	1563	8.20
11400	3304	1420	5.02	1446	5.45	1471	5.90	1495	6.34	1518	6.79	1563	7.71	1607	8.61	1649	9.50
12200	3536	1520	6.15	1544	6.62	1568	7.09	1590	7.56	1612	8.04	1655	9.02	1696	10.01	1737	10.95
13000	3768	1620	7.45	1642	7.94	1665	8.44	1686	8.95	1707	9.45	1748	10.49	1786	11.54	1825	12.57
13800	4000	1719	8.91	1741	9.43	1762	9.96	1782	10.50	1802	11.04	1841	12.13	1878	13.23	1914	14.36
14600	4231	1819	10.55	1839	11.10	1859	11.66	1879	12.22	1898	12.79	1935	13.94	1970	15.11	2005	16.29
15400	4463	1919	12.38	1938	12.96	1957	13.55	1975	14.15	1994	14.74	2029	15.95	2063	17.18	2096	18.41
16200	4695	2019	14.41	2037	15.02	2055	15.64	2072	16.26	2090	16.89	2124	18.16	<b>2157</b>	<b>19.44</b>	<b>2189</b>	<b>20.75</b>

**NOTE:** See pages 27, 29 or 30 for minimum motor frame sizes regardless of BHP.

VOLUME CFM	O.V. FPM	3" SP		4" SP		5" SP		6" SP		7" SP		8" SP		9" SP		10" SP	
		RPM	BHP	RPM	BHP	RPM	BHP	RPM	BHP	RPM	BHP	RPM	BHP	RPM	BHP	RPM	BHP
5000	1449	1155	3.32	1317	4.60												
5800	1681	1190	3.75	1335	5.12	1475	6.59	1608	8.13								
6600	1913	1246	4.34	1369	5.70	1497	7.26	1620	8.91	1742	10.62	1855	12.39				
7400	2144	1312	5.06	1422	6.44	1532	7.98	1648	9.72	1754	11.54	1867	13.43	1974	15.36	2074	17.35
8200	2376	1381	5.88	1486	7.36	1584	8.91	1682	10.59	1788	12.51	1888	14.49	1986	16.54	2086	18.64
9000	2608	1453	6.81	1554	8.39	1648	10.03	1736	11.74	1823	13.54	1922	15.62	2015	17.76	2103	19.96
9800	2840	1526	7.85	1625	9.54	1715	11.29	1800	13.09	1882	14.94	1958	16.83	2050	19.06	<b>2138</b>	<b>21.36</b>
10600	3072	1606	9.05	1696	10.83	1785	12.68	1867	14.57	1945	16.52	2021	18.52	2093	20.56	<b>2172</b>	<b>22.82</b>
11400	3304	1690	10.40	1770	12.25	1856	14.20	1936	16.20	2012	18.25	2085	20.35	<b>2156</b>	<b>22.49</b>	<b>2224</b>	<b>24.67</b>
12200	3536	1776	11.90	1850	13.84	1929	15.88	2007	17.99	2082	20.14	<b>2152</b>	<b>22.33</b>	<b>2220</b>	<b>24.57</b>	<b>2288</b>	<b>26.85</b>
13000	3768	1862	13.57	1934	15.62	2002	17.72	2079	19.94	<b>2152</b>	<b>22.19</b>	<b>2222</b>	<b>24.49</b>	<b>2288</b>	<b>26.82</b>	<b>2352</b>	<b>29.20</b>
13800	4000	1950	15.42	2020	17.58	2085	19.77	<b>2153</b>	<b>22.05</b>	<b>2224</b>	<b>24.41</b>	<b>2292</b>	<b>26.82</b>	<b>2357</b>	<b>29.25</b>	<b>2420</b>	<b>31.73</b>
14600	4231	2039	17.46	2106	19.72	<b>2169</b>	<b>22.02</b>	<b>2230</b>	<b>24.37</b>	<b>2297</b>	<b>26.82</b>	<b>2364</b>	<b>29.33</b>	<b>2428</b>	<b>31.87</b>	<b>2490</b>	<b>34.45</b>
15400	4463	2129	19.67	<b>2193</b>	<b>22.06</b>	<b>2255</b>	<b>24.47</b>	<b>2314</b>	<b>26.92</b>	<b>2371</b>	<b>29.41</b>	<b>2436</b>	<b>32.03</b>	<b>2500</b>	<b>34.68</b>	<b>2560</b>	<b>37.37</b>
16200	4695	<b>2220</b>	<b>22.05</b>	<b>2281</b>	<b>24.62</b>	<b>2341</b>	<b>27.13</b>	<b>2398</b>	<b>29.68</b>	<b>2454</b>	<b>32.28</b>	<b>2510</b>	<b>34.94</b>	<i>2572</i>	<i>37.70</i>	<i>2632</i>	<i>40.49</i>

VOLUME CFM	O.V. FPM	11" SP		12" SP		13" SP		14" SP		15" SP		16" SP		17" SP		18" SP	
		RPM	BHP	RPM	BHP	RPM	BHP	RPM	BHP	RPM	BHP	RPM	BHP	RPM	BHP	RPM	BHP
8200	2376	<b>2182</b>	<b>20.79</b>	<b>2274</b>	<b>22.99</b>	<b>2361</b>	<b>25.23</b>										
9000	2608	<b>2194</b>	<b>22.23</b>	<b>2286</b>	<b>24.54</b>	<b>2374</b>	<b>26.90</b>	<b>2458</b>	<b>29.29</b>	<b>2539</b>	<b>31.73</b>	<i>2618</i>	<i>34.21</i>				
9800	2840	<b>2221</b>	<b>23.71</b>	<b>2302</b>	<b>26.12</b>	<b>2386</b>	<b>28.59</b>	<b>2470</b>	<b>31.10</b>	<b>2552</b>	<b>33.66</b>	<i>2630</i>	<i>36.25</i>	<i>2707</i>	<i>38.88</i>	<i>2781</i>	<i>41.54</i>
10600	3072	<b>2256</b>	<b>25.28</b>	<b>2336</b>	<b>27.78</b>	<b>2413</b>	<b>30.34</b>	<b>2487</b>	<b>32.95</b>	<b>2564</b>	<b>35.62</b>	<i>2643</i>	<i>38.32</i>	<i>2719</i>	<i>41.07</i>	<i>2793</i>	<i>43.85</i>
11400	3304	<b>2291</b>	<b>26.91</b>	<b>2370</b>	<b>29.52</b>	<b>2447</b>	<b>32.18</b>	<b>2521</b>	<b>34.89</b>	<i>2592</i>	<i>37.65</i>	<i>2661</i>	<i>40.45</i>	<i>2731</i>	<i>43.30</i>	<i>2805</i>	<i>46.19</i>
12200	3536	<b>2352</b>	<b>29.17</b>	<b>2414</b>	<b>31.53</b>	<b>2482</b>	<b>34.10</b>	<b>2555</b>	<b>36.91</b>	<i>2627</i>	<i>39.77</i>	<i>2695</i>	<i>42.66</i>	<i>2762</i>	<i>45.61</i>	<i>2827</i>	<i>48.59</i>
13000	3768	<b>2416</b>	<b>31.62</b>	<b>2477</b>	<b>34.08</b>	<b>2536</b>	<b>36.57</b>	<i>2594</i>	<i>39.10</i>	<i>2661</i>	<i>41.97</i>	<i>2730</i>	<i>44.97</i>	<i>2797</i>	<i>48.01</i>		
13800	4000	<b>2480</b>	<b>34.24</b>	<b>2541</b>	<b>36.80</b>	<i>2599</i>	<i>39.40</i>	<i>2656</i>	<i>42.02</i>	<i>2711</i>	<i>44.68</i>	<i>2765</i>	<i>47.37</i>	<i>2831</i>	<i>50.51</i>		
14600	4231	<b>2549</b>	<b>37.07</b>	<i>2606</i>	<i>39.72</i>	<i>2664</i>	<i>42.41</i>	<i>2720</i>	<i>45.14</i>	<i>2774</i>	<i>47.90</i>	<i>2828</i>	<i>50.69</i>				

Performance certified is for installation type B - Free inlet, Ducted Outlet. Performance ratings do not include the effects of appurtenances (accessories). Power rating (BHP) does not include transmission losses.

# HDBI-270

**WHEEL**  
Dia. - 27.00"

**OUTLET O.D.**  
Size - 20.44" x 30.13"  
Area - 4.19 Sq. Ft. I.D.

**INLET O.D.**  
Size - 30.00"  
Area - 4.83 Sq.Ft. I.D.

## BELT DRIVE RATING TABLES

Ratings at 70°F., .075 Density, Sea Level

All wheels are HDBI type  
Class II = light face above Class III  
**Class III = bold face**  
Class IV = italic face below Class III

SEE PAGE 24 FOR MAX. WHEEL RPM & WR<sup>2</sup>.

VOLUME CFM	O.V. FPM	0" SP		1/4" SP		1/2" SP		3/4" SP		1" SP		1 1/2" SP		2" SP	
		RPM	BHP	RPM	BHP	RPM	BHP	RPM	BHP	RPM	BHP	RPM	BHP	RPM	BHP
5600	1336	500	.38	551	.59	599	.81	644	1.04	688	1.27	777	1.80		
6400	1527	571	.57	617	.81	660	1.06	700	1.31	739	1.57	814	2.11	894	2.73
7200	1718	643	.82	684	1.08	722	1.36	760	1.63	794	1.92	865	2.51	932	3.14
8000	1909	714	1.12	752	1.41	786	1.72	821	2.02	853	2.33	916	2.98	978	3.64
8800	2100	786	1.49	820	1.81	852	2.14	883	2.48	914	2.82	971	3.51	1029	4.23
9600	2291	857	1.94	889	2.29	919	2.64	947	3.01	975	3.38	1030	4.12	1082	4.90
10400	2482	928	2.46	958	2.84	986	3.23	1012	3.62	1038	4.02	1091	4.82	1139	5.64
11200	2673	1000	3.07	1027	3.48	1054	3.89	1079	4.32	1103	4.75	1152	5.60	1198	6.48
12000	2863	1071	3.78	1097	4.22	1122	4.66	1145	5.11	1168	5.56	1213	6.48	1259	7.41
12800	3054	1143	4.59	1167	5.05	1190	5.52	1213	6.00	1234	6.48	1276	7.47	1320	8.44
13600	3245	1214	5.50	1237	5.99	1259	6.49	1280	7.00	1301	7.51	1341	8.55	1381	9.59
14400	3436	1285	6.53	1307	7.05	1328	7.58	1348	8.11	1368	8.65	1406	9.75	1444	10.85
15200	3627	1357	7.68	1377	8.23	1397	8.79	1417	9.35	1436	9.92	1472	11.06	1507	12.24
16000	3818	1428	8.96	1448	9.54	1467	10.12	1485	10.71	1504	11.31	1539	12.51	1572	13.74
16800	4009	1500	10.38	1518	10.98	1537	11.59	1554	12.21	1572	12.83	1605	14.09	1638	15.37
17600	4200	1571	11.93	1589	12.56	1606	13.20	1623	13.85	1640	14.50	1673	15.81	1704	17.15
18400	4391	1642	13.63	1660	14.28	1676	14.96	1693	15.63	1709	16.31	1740	17.68	1770	19.07
19200	4582	1714	15.49	1730	16.17	1746	16.87	1762	17.58	1778	18.28	1808	19.71	1837	21.15
20000	4773	1785	17.50	1801	18.21	1816	18.95	1832	19.68	1847	20.41	<b>1876</b>	<b>21.89</b>	<b>1904</b>	<b>23.39</b>

**NOTE:** See pages 27, 29 or 30 for minimum motor frame sizes regardless of BHP.

VOLUME CFM	O.V. FPM	2 1/2" SP		3" SP		4" SP		5" SP		6" SP		7" SP		8" SP	
		RPM	BHP	RPM	BHP	RPM	BHP	RPM	BHP	RPM	BHP	RPM	BHP	RPM	BHP
8000	1909	1039	4.36	1103	5.14										
8800	2100	1085	4.97	1140	5.76	1253	7.50								
9600	2291	1136	5.69	1186	6.49	1290	8.28	1390	10.20						
10400	2482	1187	6.48	1237	7.34	1328	9.12	1427	11.15	1518	13.25				
11200	2673	1242	7.37	1288	8.28	1376	10.15	1464	12.17	1554	14.37	1638	16.64		
12000	2863	1301	8.35	1341	9.32	1427	11.29	1506	13.32	1591	15.58	1674	17.95	1752	20.38
12800	3054	1361	9.44	1400	10.46	1479	12.54	1557	14.67	1629	16.86	1711	19.34	1789	21.87
13600	3245	1421	10.64	1459	11.70	1531	13.89	1607	16.13	1678	18.41	1749	20.82	1826	23.46
14400	3436	1482	11.95	1519	13.07	1588	15.36	1659	17.70	1729	20.09	1795	22.53	<b>1863</b>	<b>25.13</b>
15200	3627	1544	13.39	1580	14.56	1647	16.95	1712	19.40	1780	21.89	1845	24.43	<b>1907</b>	<b>27.02</b>
16000	3818	1606	14.96	1641	16.18	1707	18.67	1769	21.22	1832	23.83	<b>1896</b>	<b>26.47</b>	<b>1957</b>	<b>29.16</b>
16800	4009	1669	16.67	1703	17.95	1767	20.54	1827	23.19	<b>1885</b>	<b>25.90</b>	<b>1948</b>	<b>28.64</b>	<b>2008</b>	<b>31.43</b>
17600	4200	1734	18.50	1765	19.85	1828	22.55	<b>1887</b>	<b>25.30</b>	<b>1943</b>	<b>28.11</b>	<b>2000</b>	<b>30.96</b>	<b>2059</b>	<b>33.86</b>
18400	4391	1800	20.48	1828	21.90	<b>1889</b>	<b>24.71</b>	<b>1947</b>	<b>27.56</b>	<b>2002</b>	<b>30.47</b>	<b>2054</b>	<b>33.43</b>	<b>2111</b>	<b>36.43</b>
19200	4582	<b>1866</b>	<b>22.61</b>	<b>1893</b>	<b>24.09</b>	<b>1951</b>	<b>27.03</b>	<b>2007</b>	<b>29.99</b>	<b>2061</b>	<b>33.00</b>	<b>2112</b>	<b>36.06</b>	<b>2163</b>	<b>39.16</b>
20000	4773	<b>1932</b>	<b>24.91</b>	<b>1959</b>	<b>26.44</b>	<b>2013</b>	<b>29.51</b>	<b>2068</b>	<b>32.57</b>	<b>2121</b>	<b>35.69</b>	<b>2171</b>	<b>38.85</b>	<b>2220</b>	<b>42.06</b>

VOLUME CFM	O.V. FPM	9" SP		10" SP		11" SP		12" SP		13" SP		14" SP		15" SP	
		RPM	BHP	RPM	BHP	RPM	BHP	RPM	BHP	RPM	BHP	RPM	BHP	RPM	BHP
12800	3054	<b>1862</b>	<b>24.46</b>												
13600	3245	<b>1898</b>	<b>26.15</b>	<b>1967</b>	<b>28.90</b>										
14400	3436	<b>1935</b>	<b>27.93</b>	<b>2004</b>	<b>30.78</b>	<b>2070</b>	<b>33.69</b>								
15200	3627	<b>1973</b>	<b>29.81</b>	<b>2041</b>	<b>32.77</b>	<b>2106</b>	<b>35.77</b>	<b>2169</b>	<b>38.83</b>	<b>2229</b>	<b>41.93</b>				
16000	3818	<b>2015</b>	<b>31.89</b>	<b>2078</b>	<b>34.85</b>	<b>2143</b>	<b>37.97</b>	<b>2206</b>	<b>41.13</b>						
16800	4009	<b>2065</b>	<b>34.27</b>	<b>2120</b>	<b>37.14</b>	<b>2181</b>	<b>40.27</b>	<b>2243</b>	<b>43.53</b>	2266	44.33	2324	47.58		
17600	4200	<b>2115</b>	<b>36.79</b>	<b>2170</b>	<b>39.77</b>	<b>2222</b>	<b>42.78</b>	2280	46.05	2302	46.84	2360	50.19	2416	53.59
18400	4391	<b>2167</b>	<b>39.47</b>	<b>2220</b>	<b>42.54</b>	2272	45.66	2322	48.81	2339	49.47	2397	52.93	2453	56.42
										2377	52.21	2434	55.78		
19200	4582	<b>2218</b>	<b>42.31</b>	2271	45.48	2322	48.70	2372	51.95	2420	55.24	2472	58.75		
20000	4773	2271	45.31	2323	48.59	2373	51.91	2422	55.26	2470	58.65				

Performance certified is for installation type B - Free inlet, Ducted Outlet. Performance ratings do not include the effects of appurtenances (accessories). Power rating (BHP) does not include transmission losses.

# HDBI-300

**WHEEL**  
Dia. - 30.00"

**OUTLET O.D.**  
Size - 22.75" x 33.56"  
Area - 5.20 Sq. Ft. I.D.

**INLET O.D.**  
Size - 33.50"  
Area - 6.12 Sq.Ft. I.D.

## BELT DRIVE RATING TABLES

Ratings at 70°F., .075 Density, Sea Level

All wheels are HDBI type  
Class II = light face above Class III  
**Class III = bold face**  
Class IV = italic face below Class III

SEE PAGE 24 FOR MAX. WHEEL RPM & WR<sup>2</sup>.

VOLUME CFM	O.V. FPM	0" SP		1/4" SP		1/2" SP		3/4" SP		1" SP		1 1/2" SP		2" SP	
		RPM	BHP	RPM	BHP	RPM	BHP	RPM	BHP	RPM	BHP	RPM	BHP	RPM	BHP
8000	1538	521	.74	561	1.03	599	1.34	635	1.65	670	1.97	737	2.65	808	3.42
9000	1730	586	1.05	622	1.38	656	1.72	690	2.07	721	2.42	783	3.16	842	3.94
10000	1923	651	1.44	684	1.80	715	2.18	745	2.56	775	2.95	830	3.75	886	4.58
11000	2115	716	1.91	747	2.31	775	2.73	802	3.15	830	3.57	881	4.43	933	5.33
12000	2307	781	2.48	809	2.92	836	3.36	861	3.82	886	4.28	935	5.21	981	6.17
13000	2500	846	3.15	872	3.63	897	4.11	921	4.60	943	5.10	990	6.10	1034	7.12
14000	2692	911	3.94	936	4.45	959	4.96	981	5.49	1003	6.03	1046	7.10	1088	8.18
15000	2884	976	4.85	999	5.39	1021	5.94	1042	6.50	1062	7.07	1103	8.22	1143	9.37
16000	3076	1041	5.88	1063	6.46	1084	7.05	1104	7.64	1123	8.25	1160	9.48	1199	10.69
17000	3269	1106	7.05	1127	7.67	1146	8.29	1165	8.92	1184	9.56	1219	10.86	1255	12.16
18000	3461	1171	8.37	1191	9.02	1209	9.68	1227	10.35	1245	11.02	1279	12.38	1312	13.77
19000	3653	1236	9.85	1255	10.53	1272	11.22	1290	11.93	1307	12.63	1339	14.07	1370	15.53
20000	3846	1302	11.49	1319	12.20	1336	12.94	1352	13.67	1368	14.41	1400	15.91	1430	17.44
21000	4038	1367	13.30	1383	14.05	1399	14.82	1415	15.58	1431	16.36	1461	17.93	1490	19.53
22000	4230	1432	15.29	1448	16.07	1463	16.88	1478	17.68	1493	18.49	1522	20.14	1550	21.80
23000	4423	1497	17.47	1512	18.29	1527	19.13	1541	19.97	1556	20.82	1584	22.53	1611	24.26
24000	4615	1562	19.85	1576	20.69	1591	21.58	1605	22.46	1618	23.34	1645	25.12	1672	26.92
25000	4807	1627	22.43	1641	23.33	1655	24.23	1668	25.15	<b>1681</b>	<b>26.07</b>	<b>1707</b>	<b>27.92</b>	<b>1733</b>	<b>29.78</b>

**NOTE:** See pages 27, 29 or 30 for minimum motor frame sizes regardless of BHP.

VOLUME CFM	O.V. FPM	2 1/2" SP		3" SP		4" SP		5" SP		6" SP		7" SP		8" SP	
		RPM	BHP	RPM	BHP	RPM	BHP	RPM	BHP	RPM	BHP	RPM	BHP	RPM	BHP
10000	1923	939	5.46	997	6.44										
11000	2115	982	6.25	1031	7.22	1133	9.38								
12000	2307	1029	7.16	1074	8.17	1166	10.37	1256	12.76						
13000	2500	1076	8.17	1120	9.24	1201	11.45	1290	13.96	1371	16.58				
14000	2692	1127	9.30	1167	10.44	1247	12.77	1324	15.26	1405	18.00	1480	20.82		
15000	2884	1181	10.55	1217	11.75	1293	14.21	1364	16.75	1439	19.52	1513	22.47	1583	25.50
16000	3076	1235	11.93	1270	13.20	1340	15.79	1410	18.45	1475	21.19	1547	24.23	1616	27.39
17000	3269	1290	13.46	1324	14.79	1388	17.51	1456	20.30	1520	23.16	1581	26.10	1650	29.39
18000	3461	1346	15.14	1379	16.53	1441	19.38	1504	22.30	1566	25.28	1625	28.33	<b>1684</b>	<b>31.51</b>
19000	3653	1403	16.97	1435	18.43	1495	21.40	1552	24.45	1613	27.57	1671	30.74	<b>1727</b>	<b>33.97</b>
20000	3846	1460	18.98	1491	20.50	1549	23.60	1605	26.78	1661	30.02	<b>1718</b>	<b>33.32</b>	<b>1772</b>	<b>36.68</b>
21000	4038	1518	21.15	1547	22.75	1604	25.98	1658	29.28	<b>1710</b>	<b>32.65</b>	<b>1765</b>	<b>36.08</b>	<b>1819</b>	<b>39.56</b>
22000	4230	1577	23.49	1604	25.18	1660	28.54	<b>1713</b>	<b>31.97</b>	<b>1763</b>	<b>35.46</b>	<b>1813</b>	<b>39.02</b>	<b>1866</b>	<b>42.64</b>
23000	4423	1637	26.01	1662	27.79	<b>1716</b>	<b>31.29</b>	<b>1767</b>	<b>34.85</b>	<b>1817</b>	<b>38.48</b>	<b>1863</b>	<b>42.16</b>	<b>1913</b>	<b>45.90</b>
24000	4615	<b>1697</b>	<b>28.74</b>	<b>1722</b>	<b>30.58</b>	<b>1772</b>	<b>34.25</b>	<b>1823</b>	<b>37.94</b>	<b>1871</b>	<b>41.69</b>	<b>1917</b>	<b>45.50</b>	<b>1961</b>	<b>49.37</b>
25000	4807	<b>1757</b>	<b>31.68</b>	<b>1781</b>	<b>33.59</b>	<b>1829</b>	<b>37.42</b>	<b>1878</b>	<b>41.24</b>	<b>1925</b>	<b>45.12</b>	<b>1971</b>	<b>49.06</b>	<b>2014</b>	<b>53.05</b>

VOLUME CFM	O.V. FPM	9" SP		10" SP		11" SP		12" SP		13" SP	
		RPM	BHP	RPM	BHP	RPM	BHP	RPM	BHP	RPM	BHP
15000	2884	<b>1693</b>	<b>29.09</b>								
16000	3076	<b>1682</b>	<b>30.61</b>								
17000	3269	<b>1715</b>	<b>32.75</b>	<b>1778</b>	<b>36.17</b>						
18000	3461	<b>1749</b>	<b>35.00</b>	<b>1811</b>	<b>38.55</b>	<b>1870</b>	<b>42.16</b>				
19000	3653	<b>1783</b>	<b>37.37</b>	<b>1845</b>	<b>41.06</b>	<b>1903</b>	<b>44.80</b>	<b>1960</b>	<b>48.60</b>	<b>2014</b>	<b>52.46</b>
20000	3846	<b>1824</b>	<b>40.09</b>	<b>1879</b>	<b>43.70</b>	<b>1937</b>	<b>47.57</b>	<b>1993</b>	<b>51.51</b>	<b>2047</b>	<b>55.49</b>
21000	4038	<b>1870</b>	<b>43.10</b>	<b>1919</b>	<b>46.68</b>	<b>1971</b>	<b>50.48</b>	<b>2027</b>	<b>54.55</b>	<i>2081</i>	<i>58.67</i>
22000	4230	<b>1916</b>	<b>46.30</b>	<b>1965</b>	<b>50.01</b>	<b>2012</b>	<b>53.77</b>	<b>2061</b>	<b>57.74</b>	<i>2115</i>	<i>61.99</i>
23000	4423	<b>1963</b>	<b>49.69</b>	<b>2011</b>	<b>53.53</b>	<b>2057</b>	<b>57.42</b>	<i>2102</i>	<i>61.35</i>	<i>2149</i>	<i>65.46</i>
24000	4615	<b>2010</b>	<b>53.29</b>	<b>2058</b>	<b>57.26</b>	<i>2104</i>	<i>61.27</i>	<i>2148</i>	<i>65.33</i>	<i>2191</i>	<i>69.43</i>
25000	4807	<b>2058</b>	<b>57.11</b>	<i>2105</i>	<i>61.20</i>	<i>2150</i>	<i>65.34</i>	<i>2194</i>	<i>69.53</i>	<i>2237</i>	<i>73.75</i>

Performance certified is for installation type B - Free inlet, Ducted Outlet. Performance ratings do not include the effects of appurtenances (accessories). Power rating (BHP) does not include transmission losses.

# HDBI-330

**WHEEL**  
Dia. -33.00"

**OUTLET O.D.**  
Size - 24.88" x 36.88"  
Area - 6.2 Sq. Ft. I.D.

**INLET O.D.**  
Size - 36.75"  
Area - 7.20 Sq.Ft. I.D.

## BELT DRIVE RATING TABLES

Ratings at 70°F., .075 Density, Sea Level

All wheels are HDBI type  
Class II = light face above Class III  
**Class III = bold face**  
Class IV = italic face below Class III

SEE PAGE 24 FOR MAX. WHEEL RPM & WR<sup>2</sup>.

VOLUME CFM	O.V. FPM	0" SP		1" SP		2" SP		3" SP		4" SP		5" SP		6" SP	
		RPM	BHP	RPM	BHP	RPM	BHP	RPM	BHP	RPM	BHP	RPM	BHP	RPM	BHP
12000	1935	587	1.69	700	3.51	812	5.67	911	7.94						
13000	2096	636	2.15	742	4.11	843	6.34	943	8.92	1025	11.19				
14000	2258	684	2.69	784	4.79	875	7.06	973	9.78	1057	12.40	1130	14.87		
15000	2419	733	3.31	826	5.56	910	7.91	1004	10.72	1088	13.72	1161	16.33		
16000	2580	782	4.02	869	6.41	951	8.89	1035	11.72	1118	14.86	1192	17.89	1258	20.69
17000	2741	831	4.82	914	7.35	991	9.97	1067	12.81	1149	16.09	1224	19.50	1289	22.51
18000	2903	880	5.72	959	8.39	1033	11.15	1100	14.01	1180	17.40	1254	20.94	1321	24.45
19000	3064	929	6.73	1004	9.54	1074	12.45	1140	15.43	1212	18.79	1284	22.47	1352	26.27
20000	3225	978	7.84	1050	10.80	1117	13.85	1181	16.97	1243	20.28	1315	24.10	1382	28.03
21000	3387	1027	9.08	1096	12.17	1159	15.38	1222	18.62	1279	21.97	1347	25.83	1413	29.90
22000	3548	1076	10.44	1142	13.67	1202	17.03	1263	20.41	1319	23.88	1379	27.66	1444	31.87
23000	3709	1125	11.93	1188	15.30	1246	18.81	1305	22.32	1360	25.92	1411	29.61	1475	33.94
24000	3870	1173	13.56	1235	17.07	1291	20.71	1347	24.38	1400	28.10	1451	31.92	<b>1507</b>	<b>36.14</b>
25000	4032	1222	15.32	1281	18.97	1336	22.75	1389	26.58	1442	30.43	1491	34.38	<b>1539</b>	<b>38.45</b>
26000	4193	1271	17.23	1328	21.03	1381	24.94	1432	28.93	1483	32.92	<b>1532</b>	<b>36.99</b>	<b>1578</b>	<b>41.14</b>
27000	4354	1320	19.30	1375	23.23	1426	27.29	1475	31.44	<b>1525</b>	<b>35.55</b>	<b>1573</b>	<b>39.75</b>	<b>1618</b>	<b>44.03</b>
28000	4516	1369	21.53	1422	25.60	1472	29.79	<b>1519</b>	<b>34.09</b>	<b>1567</b>	<b>38.35</b>	<b>1614</b>	<b>42.68</b>	<b>1658</b>	<b>47.09</b>
29000	4677	1418	23.92	1469	28.13	<b>1518</b>	<b>32.46</b>	<b>1563</b>	<b>36.89</b>	<b>1610</b>	<b>41.32</b>	<b>1655</b>	<b>45.78</b>	<b>1699</b>	<b>50.31</b>
30000	4838	1467	26.48	<b>1517</b>	<b>30.84</b>	<b>1564</b>	<b>35.30</b>	<b>1608</b>	<b>39.87</b>	<b>1652</b>	<b>44.47</b>	<b>1697</b>	<b>49.05</b>	<b>1740</b>	<b>53.72</b>
31000	5000	<b>1516</b>	<b>29.21</b>	<b>1564</b>	<b>33.71</b>	<b>1610</b>	<b>38.32</b>	<b>1653</b>	<b>43.02</b>	<b>1695</b>	<b>47.79</b>	<b>1739</b>	<b>52.51</b>	<b>1781</b>	<b>57.30</b>
32000	5161	<b>1565</b>	<b>32.13</b>	<b>1612</b>	<b>36.77</b>	<b>1656</b>	<b>41.52</b>	<b>1698</b>	<b>46.36</b>	<b>1739</b>	<b>51.28</b>	<b>1782</b>	<b>56.15</b>	<b>1823</b>	<b>61.07</b>
33000	5322	<b>1613</b>	<b>35.24</b>	<b>1659</b>	<b>40.02</b>	<b>1702</b>	<b>44.91</b>	<b>1744</b>	<b>49.88</b>	<b>1783</b>	<b>54.95</b>	<b>1824</b>	<b>59.99</b>	<b>1865</b>	<b>65.04</b>
34000	5483	<b>1662</b>	<b>38.54</b>	<b>1707</b>	<b>43.47</b>	<b>1749</b>	<b>48.49</b>	<b>1789</b>	<b>53.60</b>	<b>1828</b>	<b>58.80</b>	<b>1867</b>	<b>64.02</b>	<b>1907</b>	<b>69.20</b>

**NOTE:** See pages 28 and 30 for minimum motor frame sizes regardless of BHP.

VOLUME CFM	O.V. FPM	7" SP		8" SP		9" SP		10" SP		11" SP		12" SP		13" SP	
		RPM	BHP	RPM	BHP	RPM	BHP	RPM	BHP	RPM	BHP	RPM	BHP	RPM	BHP
17000	2741	1350	25.50												
18000	2903	1381	27.58	1438	30.76										
19000	3064	1413	29.79	1469	33.10	<b>1522</b>	<b>36.47</b>								
20000	3225	1445	32.07	1500	35.59	<b>1553</b>	<b>39.09</b>	<b>1604</b>	<b>42.63</b>						
21000	3387	1475	34.07	<b>1532</b>	<b>38.22</b>	<b>1585</b>	<b>41.86</b>	<b>1635</b>	<b>45.54</b>	<b>1683</b>	<b>49.26</b>				
22000	3548	<b>1505</b>	<b>36.17</b>	<b>1563</b>	<b>40.58</b>	<b>1617</b>	<b>44.78</b>	<b>1666</b>	<b>48.60</b>	<b>1714</b>	<b>52.45</b>	<b>1760</b>	<b>56.35</b>		
23000	3709	<b>1536</b>	<b>38.39</b>	<b>1593</b>	<b>42.93</b>	<b>1648</b>	<b>47.57</b>	<b>1698</b>	<b>51.82</b>	<b>1745</b>	<b>55.81</b>	<b>1791</b>	<b>59.84</b>	<b>1835</b>	<b>63.92</b>
24000	3870	<b>1567</b>	<b>40.72</b>	<b>1624</b>	<b>45.40</b>	<b>1678</b>	<b>50.17</b>	<b>1729</b>	<b>55.03</b>	<b>1777</b>	<b>59.34</b>	<b>1822</b>	<b>63.51</b>	<b>1866</b>	<b>67.72</b>
25000	4032	<b>1598</b>	<b>43.17</b>	<b>1655</b>	<b>47.98</b>	<b>1708</b>	<b>52.89</b>	<b>1759</b>	<b>57.88</b>	<b>1809</b>	<b>62.96</b>	<b>1854</b>	<b>67.35</b>	<i>1897</i>	<i>71.69</i>
26000	4193	<b>1630</b>	<b>45.74</b>	<b>1686</b>	<b>50.69</b>	<b>1739</b>	<b>55.73</b>	<b>1790</b>	<b>60.86</b>	<b>1839</b>	<b>66.08</b>	<i>1886</i>	<i>71.37</i>	<i>1929</i>	<i>75.85</i>
27000	4354	<b>1662</b>	<b>48.44</b>	<b>1717</b>	<b>53.53</b>	<b>1770</b>	<b>58.71</b>	<b>1821</b>	<b>63.97</b>	<b>1869</b>	<b>69.32</b>	<i>1916</i>	<i>74.75</i>	<i>1961</i>	<i>80.20</i>
28000	4516	<b>1701</b>	<b>51.57</b>	<b>1749</b>	<b>56.50</b>	<b>1801</b>	<b>61.82</b>	<b>1852</b>	<b>67.22</b>	<i>1900</i>	<i>72.70</i>	<i>1946</i>	<i>78.26</i>	<i>1991</i>	<i>83.90</i>
29000	4677	<b>1741</b>	<b>54.92</b>	<b>1781</b>	<b>59.61</b>	<b>1833</b>	<b>65.07</b>	<i>1883</i>	<i>70.61</i>	<i>1930</i>	<i>76.22</i>	<i>1977</i>	<i>81.92</i>	<i>2021</i>	<i>87.69</i>
30000	4838	<b>1781</b>	<b>58.45</b>	<b>1821</b>	<b>63.25</b>	<b>1865</b>	<b>68.46</b>	<i>1914</i>	<i>74.14</i>	<i>1962</i>	<i>79.89</i>	<i>2007</i>	<i>85.72</i>	<i>2052</i>	<i>91.63</i>
31000	5000	<b>1822</b>	<b>62.16</b>	<b>1861</b>	<b>67.09</b>	<i>1899</i>	<i>72.08</i>	<i>1946</i>	<i>77.82</i>	<i>1993</i>	<i>83.71</i>	<i>2038</i>	<i>89.68</i>	<i>2082</i>	<i>95.72</i>
32000	5161	<b>1863</b>	<b>66.06</b>	<i>1901</i>	<i>71.11</i>	<i>1939</i>	<i>76.24</i>	<i>1978</i>	<i>81.65</i>	<i>2025</i>	<i>87.68</i>	<i>2070</i>	<i>93.78</i>	<i>2113</i>	<i>99.96</i>
33000	5322	<i>1904</i>	<i>70.15</i>	<i>1942</i>	<i>75.34</i>	<i>1979</i>	<i>80.58</i>	<i>2014</i>	<i>85.89</i>	<i>2057</i>	<i>91.81</i>	<i>2101</i>	<i>98.05</i>	<i>2145</i>	<i>104.36</i>
34000	5483	<i>1946</i>	<i>74.45</i>	<i>1983</i>	<i>79.76</i>	<i>2019</i>	<i>85.13</i>	<i>2054</i>	<i>90.57</i>	<i>2089</i>	<i>96.09</i>	<i>2133</i>	<i>102.48</i>	<i>2176</i>	<i>108.93</i>

VOLUME CFM	O.V. FPM	14" SP		15" SP		16" SP		17" SP		18" SP		19" SP	
		RPM	BHP	RPM	BHP	RPM	BHP	RPM	BHP	RPM	BHP	RPM	BHP
24000	3870	<i>1908</i>	<i>71.96</i>										
25000	4032	<i>1939</i>	<i>76.07</i>	<i>1980</i>	<i>80.49</i>	<i>2020</i>	<i>84.94</i>						
26000	4193	<i>1971</i>	<i>80.37</i>	<i>2011</i>	<i>84.92</i>	<i>2050</i>	<i>89.50</i>	<i>2089</i>	<i>94.13</i>				
27000	4354	<i>2002</i>	<i>84.85</i>	<i>2042</i>	<i>89.54</i>	<i>2082</i>	<i>94.26</i>	<i>2120</i>	<i>99.02</i>	<i>2157</i>	<i>103.81</i>		
28000	4516	<i>2034</i>	<i>89.53</i>	<i>2074</i>	<i>94.36</i>	<i>2113</i>	<i>99.22</i>	<i>2151</i>	<i>104.11</i>	<i>2188</i>	<i>109.04</i>	<i>2224</i>	<i>113.99</i>
29000	4677	<i>2064</i>	<i>93.54</i>	<i>2106</i>	<i>99.38</i>	<i>2145</i>	<i>104.38</i>	<i>2182</i>	<i>109.41</i>	<i>2219</i>	<i>114.47</i>	<i>2255</i>	<i>119.56</i>
30000	4838	<i>2095</i>	<i>97.61</i>	<i>2136</i>	<i>103.66</i>	<i>2177</i>	<i>109.75</i>	<i>2214</i>	<i>114.92</i>	<i>2251</i>	<i>120.12</i>	<i>2286</i>	<i>125.35</i>
31000	5000	<i>2125</i>	<i>101.83</i>	<i>2166</i>	<i>108.02</i>	<i>2207</i>	<i>114.27</i>	<i>2246</i>	<i>120.60</i>	<i>2283</i>	<i>125.99</i>		
32000	5161	<i>2156</i>	<i>106.21</i>	<i>2197</i>	<i>112.53</i>	<i>2237</i>	<i>118.92</i>	<i>2276</i>	<i>125.38</i>				
33000	5322	<i>2187</i>	<i>110.75</i>	<i>2228</i>	<i>117.20</i>	<i>2267</i>	<i>123.73</i>						
34000	5483	<i>2218</i>	<i>115.45</i>	<i>2259</i>	<i>122.04</i>	<i>2298</i>	<i>128.70</i>						

**NOTE:**  
HDBI-330  
HAS A FIXED  
HOUSING AND  
IS THEREFORE  
NOT ROTATABLE  
IN THE FIELD.

Performance certified is for installation type B - Free inlet, Ducted Outlet. Performance ratings do not include the effects of appurtenances (accessories). Power rating (BHP) does not include transmission losses.

# HDBI-360

**WHEEL**  
Dia. -36.00"

**OUTLET O.D.**  
Size - 27.25" x 40.25"  
Area - 7.50 Sq. Ft. I.D.

**INLET O.D.**  
Size - 40"  
Area - 8.10 Sq.Ft. I.D.

## BELT DRIVE RATING TABLES

Ratings at 70°F., .075 Density, Sea Level

All wheels are HDBI type  
Class II = light face above Class III  
**Class III = bold face**  
Class IV = italic face below Class III

SEE PAGE 24 FOR MAX. WHEEL RPM & WR<sup>2</sup>.

VOLUME CFM	O.V. FPM	0" SP		1" SP		2" SP		3" SP		4" SP		5" SP		6" SP	
		RPM	BHP	RPM	BHP	RPM	BHP	RPM	BHP	RPM	BHP	RPM	BHP	RPM	BHP
24000	3200	904	9.57	969	13.11	1030	16.78	1089	20.51	1143	24.37	1201	28.32	1254	32.38
25000	3333	941	10.82	1005	14.50	1063	18.32	1120	22.18	1173	26.16	1228	30.25	1281	34.43
26000	3466	979	12.17	1040	15.99	1096	19.96	1152	23.95	1204	28.06	1255	32.28	1307	36.58
27000	3600	1017	13.63	1076	17.59	1130	21.71	1184	25.83	1235	30.07	1283	34.42	1335	38.85
28000	3733	1054	15.20	1112	19.30	1164	23.55	1216	27.84	1266	32.20	1313	36.67	1362	41.24
29000	3866	1092	16.89	1148	21.13	1198	25.52	1249	29.95	1298	34.45	1343	39.04	<b>1389</b>	<b>43.74</b>
30000	4000	1130	18.69	1184	23.08	1233	27.61	1281	32.20	1329	36.82	1375	41.54	<b>1417</b>	<b>46.37</b>
31000	4133	1167	20.63	1220	25.15	1268	29.82	1314	34.57	1361	39.32	<b>1406</b>	<b>44.17</b>	<b>1448</b>	<b>49.12</b>
32000	4266	1205	22.69	1256	27.35	1303	32.16	1347	37.07	<b>1394</b>	<b>41.95</b>	<b>1437</b>	<b>46.93</b>	<b>1479</b>	<b>52.01</b>
33000	4400	1243	24.88	1292	29.69	1338	34.63	<b>1381</b>	<b>39.70</b>	<b>1426</b>	<b>44.72</b>	<b>1469</b>	<b>49.83</b>	<b>1510</b>	<b>55.03</b>
34000	4533	1280	27.21	1328	32.16	1373	37.24	<b>1415</b>	<b>42.44</b>	<b>1459</b>	<b>47.63</b>	<b>1501</b>	<b>52.87</b>	<b>1541</b>	<b>58.20</b>
35000	4666	1318	29.68	1365	34.77	<b>1408</b>	<b>39.99</b>	<b>1450</b>	<b>45.33</b>	<b>1491</b>	<b>50.69</b>	<b>1533</b>	<b>56.05</b>	<b>1573</b>	<b>61.51</b>
36000	4800	1356	32.30	<b>1401</b>	<b>37.53</b>	<b>1444</b>	<b>42.89</b>	<b>1484</b>	<b>48.36</b>	<b>1524</b>	<b>53.89</b>	<b>1565</b>	<b>59.39</b>	<b>1605</b>	<b>64.97</b>
37000	4933	<b>1393</b>	<b>35.07</b>	<b>1438</b>	<b>40.44</b>	<b>1479</b>	<b>45.94</b>	<b>1519</b>	<b>51.55</b>	<b>1557</b>	<b>57.24</b>	<b>1598</b>	<b>62.87</b>	<b>1636</b>	<b>68.59</b>
38000	5066	<b>1431</b>	<b>37.99</b>	<b>1474</b>	<b>43.50</b>	<b>1515</b>	<b>49.14</b>	<b>1554</b>	<b>54.89</b>	<b>1591</b>	<b>60.74</b>	<b>1630</b>	<b>66.52</b>	<b>1668</b>	<b>72.36</b>
39000	5200	<b>1469</b>	<b>41.07</b>	<b>1511</b>	<b>46.73</b>	<b>1551</b>	<b>52.50</b>	<b>1589</b>	<b>58.39</b>	<b>1625</b>	<b>64.37</b>	<b>1663</b>	<b>70.32</b>	<b>1701</b>	<b>76.30</b>
40000	5333	<b>1506</b>	<b>44.31</b>	<b>1548</b>	<b>50.11</b>	<b>1587</b>	<b>56.02</b>	<b>1624</b>	<b>62.04</b>	<b>1660</b>	<b>68.17</b>	<b>1696</b>	<b>74.29</b>	<b>1733</b>	<b>80.40</b>
41000	5466	<b>1544</b>	<b>47.72</b>	<b>1584</b>	<b>53.65</b>	<b>1623</b>	<b>59.72</b>	<b>1659</b>	<b>65.87</b>	<b>1694</b>	<b>72.13</b>	<b>1729</b>	<b>78.43</b>	<i>1766</i>	<i>84.67</i>

**NOTE:** See pages 28 and 30 for minimum motor frame sizes regardless of BHP.

VOLUME CFM	O.V. FPM	7" SP		8" SP		9" SP		10" SP		11" SP		12" SP		13" SP	
		RPM	BHP	RPM	BHP	RPM	BHP	RPM	BHP	RPM	BHP	RPM	BHP	RPM	BHP
24000	3200	1308	36.67	1366	41.34	<b>1420</b>	<b>46.11</b>	<b>1472</b>	<b>50.98</b>						
25000	3333	1330	38.70	<b>1385</b>	<b>43.40</b>	<b>1440</b>	<b>48.31</b>	<b>1491</b>	<b>53.30</b>	<b>1541</b>	<b>58.38</b>				
26000	3466	1357	40.98	<b>1405</b>	<b>45.55</b>	<b>1459</b>	<b>50.58</b>	<b>1511</b>	<b>55.71</b>	<b>1560</b>	<b>60.92</b>	<b>1607</b>	<b>66.22</b>		
27000	3600	<b>1383</b>	<b>43.38</b>	<b>1429</b>	<b>47.98</b>	<b>1479</b>	<b>52.94</b>	<b>1530</b>	<b>58.20</b>	<b>1579</b>	<b>63.55</b>	<b>1626</b>	<b>68.98</b>	<b>1672</b>	<b>74.49</b>
28000	3733	<b>1410</b>	<b>45.89</b>	<b>1456</b>	<b>50.62</b>	<b>1499</b>	<b>55.43</b>	<b>1550</b>	<b>60.79</b>	<b>1599</b>	<b>66.26</b>	<b>1646</b>	<b>71.82</b>	<b>1691</b>	<b>77.46</b>
29000	3866	<b>1437</b>	<b>48.52</b>	<b>1482</b>	<b>53.38</b>	<b>1526</b>	<b>58.31</b>	<b>1570</b>	<b>63.47</b>	<b>1618</b>	<b>69.08</b>	<b>1665</b>	<b>74.77</b>	<b>1710</b>	<b>80.54</b>
30000	4000	<b>1464</b>	<b>51.28</b>	<b>1509</b>	<b>56.26</b>	<b>1552</b>	<b>61.32</b>	<b>1593</b>	<b>66.45</b>	<b>1638</b>	<b>71.98</b>	<b>1685</b>	<b>77.81</b>	<b>1729</b>	<b>83.71</b>
31000	4133	<b>1492</b>	<b>54.16</b>	<b>1536</b>	<b>59.27</b>	<b>1579</b>	<b>64.46</b>	<b>1619</b>	<b>69.72</b>	<b>1659</b>	<b>75.05</b>	<b>1704</b>	<b>80.95</b>	<i>1749</i>	<i>86.98</i>
32000	4266	<b>1519</b>	<b>57.17</b>	<b>1563</b>	<b>62.42</b>	<b>1606</b>	<b>67.73</b>	<b>1646</b>	<b>73.12</b>	<b>1685</b>	<b>78.57</b>	<b>1724</b>	<b>84.19</b>	<i>1769</i>	<i>90.36</i>
33000	4400	<b>1549</b>	<b>60.32</b>	<b>1591</b>	<b>65.70</b>	<b>1633</b>	<b>71.14</b>	<b>1673</b>	<b>76.66</b>	<b>1711</b>	<b>82.24</b>	<i>1749</i>	<i>87.88</i>	<i>1788</i>	<i>93.84</i>
34000	4533	<b>1580</b>	<b>63.62</b>	<b>1619</b>	<b>69.12</b>	<b>1660</b>	<b>74.69</b>	<b>1700</b>	<b>80.33</b>	<i>1738</i>	<i>86.04</i>	<i>1775</i>	<i>91.81</i>	<i>1811</i>	<i>97.65</i>
35000	4666	<b>1611</b>	<b>67.05</b>	<b>1648</b>	<b>72.68</b>	<b>1687</b>	<b>78.39</b>	<b>1727</b>	<b>84.16</b>	<i>1765</i>	<i>89.99</i>	<i>1802</i>	<i>95.89</i>	<i>1837</i>	<i>101.85</i>
36000	4800	<b>1642</b>	<b>70.64</b>	<b>1678</b>	<b>76.40</b>	<b>1715</b>	<b>82.23</b>	<i>1754</i>	<i>88.13</i>	<i>1792</i>	<i>94.09</i>	<i>1828</i>	<i>100.12</i>	<i>1864</i>	<i>106.20</i>
37000	4933	<b>1673</b>	<b>74.39</b>	<b>1709</b>	<b>80.27</b>	<i>1744</i>	<i>86.23</i>	<i>1782</i>	<i>92.26</i>	<i>1819</i>	<i>98.35</i>	<i>1855</i>	<i>104.50</i>	<i>1890</i>	<i>110.71</i>
38000	5066	<b>1705</b>	<b>78.29</b>	<i>1740</i>	<i>84.29</i>	<i>1774</i>	<i>90.38</i>	<i>1809</i>	<i>96.54</i>	<i>1846</i>	<i>102.76</i>	<i>1882</i>	<i>109.04</i>	<i>1917</i>	<i>115.38</i>
39000	5200	<i>1737</i>	<i>82.35</i>	<i>1772</i>	<i>88.49</i>	<i>1805</i>	<i>94.70</i>	<i>1838</i>	<i>100.98</i>	<i>1874</i>	<i>107.34</i>	<i>1910</i>	<i>113.75</i>	<i>1944</i>	<i>120.22</i>
40000	5333	<i>1769</i>	<i>86.58</i>	<i>1803</i>	<i>92.84</i>	<i>1836</i>	<i>99.18</i>	<i>1869</i>	<i>105.59</i>	<i>1902</i>	<i>112.08</i>	<i>1937</i>	<i>118.62</i>	<i>1971</i>	<i>125.22</i>
41000	5466	<i>1801</i>	<i>90.99</i>	<i>1835</i>	<i>97.38</i>	<i>1868</i>	<i>103.84</i>	<i>1900</i>	<i>110.37</i>	<i>1931</i>	<i>116.98</i>	<i>1965</i>	<i>123.66</i>	<i>1999</i>	<i>130.39</i>

**NOTE:**  
HDBI-360  
HAS A FIXED  
HOUSING AND  
IS THEREFORE  
NOT ROTATABLE  
IN THE FIELD.

VOLUME CFM	O.V. FPM	14" SP		15" SP		16" SP		17" SP	
		RPM	BHP	RPM	BHP	RPM	BHP	RPM	BHP
28000	3733	<b>1734</b>	<b>83.18</b>						
29000	3866	<i>1754</i>	<i>86.39</i>	<i>1796</i>	<i>92.31</i>				
30000	4000	<i>1773</i>	<i>89.69</i>	<i>1815</i>	<i>95.74</i>	<i>1855</i>	<i>101.87</i>		
31000	4133	<i>1792</i>	<i>93.09</i>	<i>1834</i>	<i>99.28</i>	<i>1875</i>	<i>105.54</i>	<i>1914</i>	<i>111.86</i>
32000	4266	<i>1812</i>	<i>96.60</i>	<i>1853</i>	<i>102.92</i>	<i>1894</i>	<i>109.30</i>	<i>1933</i>	<i>115.76</i>
33000	4400	<i>1831</i>	<i>100.22</i>	<i>1873</i>	<i>106.66</i>	<i>1913</i>	<i>113.18</i>	<i>1952</i>	<i>119.77</i>
34000	4533	<i>1851</i>	<i>103.94</i>	<i>1892</i>	<i>110.52</i>	<i>1933</i>	<i>117.17</i>	<i>1972</i>	<i>123.89</i>
35000	4666	<i>1872</i>	<i>107.87</i>	<i>1912</i>	<i>114.49</i>	<i>1952</i>	<i>121.28</i>	<i>1991</i>	<i>128.13</i>
36000	4800	<i>1898</i>	<i>112.36</i>	<i>1932</i>	<i>118.58</i>	<i>1972</i>	<i>125.50</i>	<i>2011</i>	<i>132.48</i>

Performance certified is for installation type B - Free inlet, Ducted Outlet. Performance ratings do not include the effects of appurtenances (accessories). Power rating (BHP) does not include transmission losses.

# DESIGN SPECIFICATIONS

## Maximum Shaft and Bearing Speeds for Belt Driven Fans Maximum Wheel Speeds & WR<sup>2</sup> (Lb.-Ft.<sup>2</sup>) for Direct Driven Fans

FAN SIZE	Maximum Shaft and Bearing Speeds			HDBI Steel Wheels ①						SQBI Steel Wheels ①				Aluminum Wheels ②	
				CLASS II		CLASS III		CLASS IV		CLASS II		CLASS III			
	CLASS II	CLASS III	CLASS IV	WHEEL WR <sup>2</sup>	MAX. RPM	WHEEL WR <sup>2</sup>	MAX. RPM	WHEEL WR <sup>2</sup>	MAX. RPM	WHEEL WR <sup>2</sup>	MAX. RPM	WHEEL WR <sup>2</sup>	MAX. RPM	WHEEL WR <sup>2</sup>	MAX. RPM
120	4189	4985	—	2.8	4380	2.8	5400	—	—	3.9	4065	4.1	5000	1.2	5400
130	3834	4738	4999	4.2	3900	—	—	4.2	4999	5.3	3750	5.7	4700	1.7	4999
150	3513	4357	4712	5.9	3513	—	—	5.9	4712	8.1	3050	8.3	4117	2.5	4712
160	3195	3961	4285	9.0	3195	—	—	9.9	4285	11.7	3042	12.4	3724	4.2	4285
180	2903	3591	3885	13.9	2903	—	—	15.0	3885	16.2	2593	17.1	3600	6.7	3885
200	2661	3285	3574	19.0	2661	—	—	20.8	3574	24.6	2380	26.5	3550	9.8	3574
220	2304	2824	3447	26.1	2304	—	—	29.1	3550	36.3	2115	39.6	3160	14.7	3550
240	2132	2565	2837	54.6	2132	—	—	58.2	2837	—	—	63.3	2740	26.5	2837
270	1854	2262	2476	—	—	—	—	89.9	2476	—	—	108.3	2493	45.9	2476
300	1680	2075	2300	—	—	—	—	130.2	2300	—	—	165.0	2243	64.3	2300
330	1500	1880	2300	—	—	—	—	193.6	2300	—	—	244.2	1935	130.0	2300
360	1380	1735	1950	—	—	—	—	255.8	1950	—	—	349.6	1750	176.0	1950

① For steel wheels up to 175°F. (80°C.)

② For aluminum wheels up to 200°F. (93°C.) All aluminum wheels are HDBI type, Class IV construction.

### Approximate Shipping Weights Less Motor

SIZE	ARR#1			ARR#4			ARR#8			ARR#9			ARR#9CB			ARR#10		
	CL.II	CL.III	CL.IV	CL.II	CL.III	CL.IV	CL.II	CL.III	CL.IV	CL.II	CL.III	CL.IV	CL.II	CL.III	CL.IV	CL.II	CL.III	CL.IV
120	160	165	170	120	125	130	180	185	190	190	195	200	260	265	270	180	185	190
130	190	195	200	150	155	160	210	215	220	210	215	220	300	305	310	200	205	210
150	220	230	240	170	180	190	250	260	270	250	260	270	340	350	360	250	260	270
160	270	280	290	230	240	255	290	310	320	300	310	320	390	400	410	300	310	320
180	350	360	370	300	310	325	380	390	400	380	390	400	500	510	520	390	400	410
200	390	410	420	350	360	380	430	450	460	430	450	460	560	580	590	430	450	460
220	470	500	510	430	440	460	520	540	550	530	550	560	660	680	690	530	550	560
240	610	620	630	550	555	560	670	690	700	660	670	680	800	810	820	620	630	640
270	740	750	760	690	695	700	820	840	850	800	810	820	960	970	980	760	770	780
300	910	945	950	840	845	850	1000	1000	1040	970	1005	1010	1130	1165	1170	900	930	940
330	1200	1320	1510	1090	1090	1176	—	—	—	1260	1380	1570	1420	1560	1760	—	—	—
360	1410	1600	1720	1390	1430	1430	—	—	—	1470	1660	1780	1650	1840	1910	—	—	—

## DIMENSIONS and SPECIFICATIONS

**NOTE: The table below contains blower housing dimensions common to all arrangements on pages 25 and 27 through 29.**

MODEL	C①	D②	J	M	O	P	R	S	AA	DD③
HDBI-120	4 <sup>1/16</sup>	9 <sup>3/8</sup>	5 <sup>3/4</sup>	6 <sup>3/16</sup>	9 <sup>15/16</sup>	12 <sup>3/8</sup>	13	10 <sup>3/8</sup>	13 <sup>1/4</sup>	13 <sup>3/4</sup>
HDBI-130	4 <sup>1/16</sup>	10 <sup>3/8</sup>	6 <sup>1/4</sup>	6 <sup>13/16</sup>	10 <sup>13/16</sup>	13 <sup>3/4</sup>	14 <sup>7/16</sup>	11 <sup>9/16</sup>	14 <sup>5/8</sup>	15 <sup>1/4</sup>
HDBI-150	4 <sup>1/16</sup>	11 <sup>3/8</sup>	6 <sup>3/4</sup>	7 <sup>9/16</sup>	11 <sup>3/4</sup>	15 <sup>3/16</sup>	15 <sup>15/16</sup>	12 <sup>3/4</sup>	16 <sup>1/8</sup>	16 <sup>13/16</sup>
HDBI-160	4 <sup>1/16</sup>	12 <sup>1/2</sup>	7 <sup>5/16</sup>	8 <sup>5/16</sup>	12 <sup>11/16</sup>	16 <sup>11/16</sup>	17 <sup>1/2</sup>	14	18	18 <sup>7/16</sup>
HDBI-180	4 <sup>1/16</sup>	13 <sup>7/8</sup>	8	9 <sup>1/4</sup>	13 <sup>13/16</sup>	18 <sup>7/16</sup>	19 <sup>7/16</sup>	15 <sup>1/2</sup>	20	20 <sup>3/8</sup>
HDBI-200	4 <sup>1/16</sup>	15 <sup>1/4</sup>	8 <sup>11/16</sup>	10 <sup>1/16</sup>	14 <sup>15/16</sup>	20 <sup>1/4</sup>	21 <sup>1/4</sup>	17	22	22 <sup>3/8</sup>
HDBI-220	4 <sup>1/16</sup>	16 <sup>7/8</sup>	9 <sup>1/2</sup>	11 <sup>3/16</sup>	16 <sup>3/8</sup>	22 <sup>1/2</sup>	23 <sup>5/8</sup>	18 <sup>7/8</sup>	24 <sup>5/8</sup>	24 <sup>7/8</sup>
HDBI-240	6 <sup>1/16</sup>	18 <sup>9/16</sup>	10 <sup>3/8</sup>	12 <sup>5/16</sup>	18 <sup>13/16</sup>	24 <sup>3/4</sup>	26	20 <sup>3/4</sup>	27	27 <sup>3/8</sup>
HDBI-270	6 <sup>1/16</sup>	20 <sup>7/16</sup>	11 <sup>5/16</sup>	13 <sup>9/16</sup>	20 <sup>5/8</sup>	27 <sup>1/4</sup>	28 <sup>5/8</sup>	22 <sup>7/8</sup>	30	30 <sup>1/16</sup>
HDBI-300	6 <sup>1/16</sup>	22 <sup>3/4</sup>	12 <sup>7/16</sup>	15 <sup>1/8</sup>	22 <sup>5/8</sup>	30 <sup>3/8</sup>	31 <sup>7/8</sup>	25 <sup>1/2</sup>	33 <sup>1/2</sup>	33 <sup>9/16</sup>
★ HDBI-330	3 <sup>1/4</sup>	24 <sup>7/8</sup>	14 <sup>1/2</sup>	16 <sup>9/16</sup>	24 <sup>11/16</sup>	33 <sup>3/8</sup>	35	28	36 <sup>3/4</sup>	36 <sup>7/8</sup>
★ HDBI-360	3 <sup>1/4</sup>	27 <sup>1/4</sup>	15 <sup>11/16</sup>	18 <sup>1/8</sup>	27 <sup>3/16</sup>	36 <sup>1/2</sup>	38 <sup>1/4</sup>	30 <sup>1/2</sup>	40	40 <sup>1/4</sup>

① Add 1/8" for AMCA "C" Construction fans and/or Downblast discharge position.

② Dimensions shown are for 100% width housings. For partial width housings, contact your local Cincinnati Fan sales representative.

③ Discharge flange is standard on Models HDBI-270 through HDBI-360. See page 31 for dimension.

★ HDBI-330 & 360 have fixed housings and are therefore not rotatable in the field.



# DIMENSIONS and SPECIFICATIONS

## Arrangement #4, Direct Drive

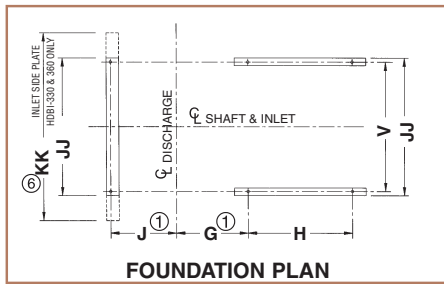
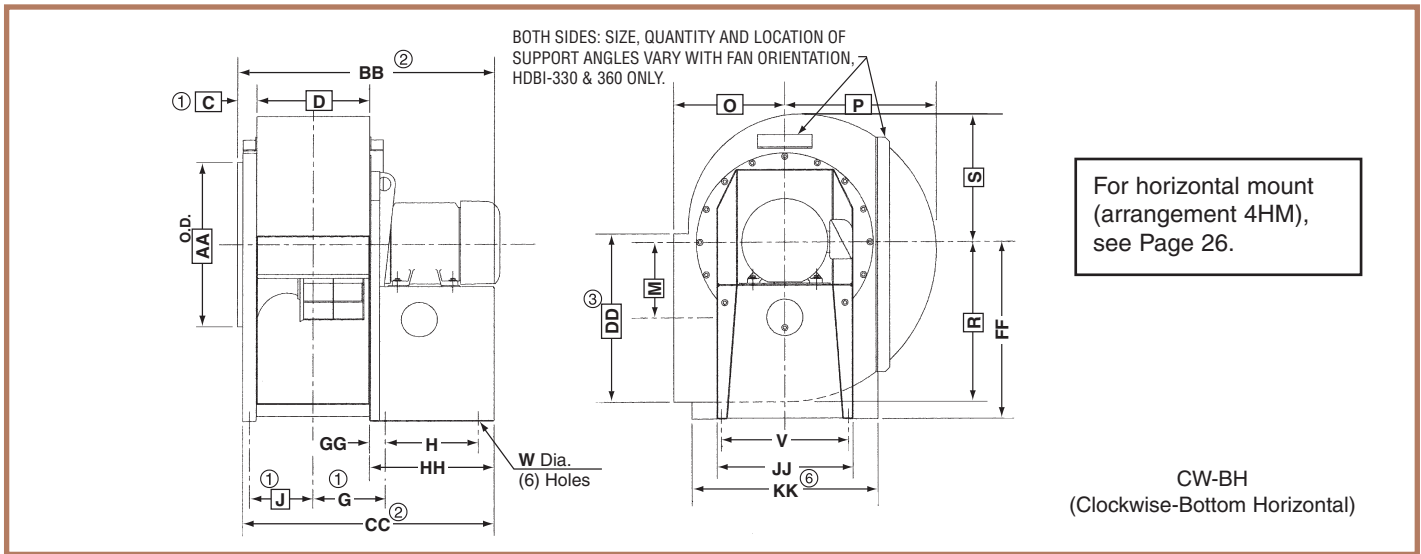

- ① Add 1/8" for AMCA "C" Construction fans and/or Downblast discharge position.
- ② Add 1/4" for AMCA "C" Construction fans and/or Downblast discharge position.
- ③ Discharge flange (not shown above) is standard on Models HDBI-270 through HDBI-360. See page 31 for dimensions.
- ⑥ Inlet side plate width for HDBI-330 & 360. Inlet side plate for HDBI-120 to HDBI-300 is same width as "JJ" dimension.

NOTE: HDBI-120 to 300 are reversible and rotatable in 45° increments but wheels are not reversible. **HDBI-330 AND 360 ARE NOT ROTATABLE OR REVERSIBLE.**

DIMENSIONS IN INCHES ± 1/8"

NOTE: For common boxed blower housing dimensions, see Page 24.

MODEL NO.	MOTOR FRAME	G①	H	V	W	BB②	CC②	FF	GG	HH	JJ	KK⑥
HDBI-120	143T-184T	7 <sup>11/16</sup>	5 1/2	14	9 <sup>1/16</sup>	24 <sup>15/16</sup>	22 <sup>15/16</sup>	15 1/2	3	11 1/2	16	—
HDBI-130	143T-215T	8 <sup>3/16</sup>	7 <sup>5/8</sup>	15 <sup>3/4</sup>	9 <sup>1/16</sup>	28 <sup>1/16</sup>	26 <sup>1/16</sup>	16 <sup>5/8</sup>	3	13 <sup>5/8</sup>	17 <sup>3/4</sup>	—
HDBI-150	143T-215T	8 <sup>11/16</sup>	7 <sup>5/8</sup>	17 <sup>1/4</sup>	9 <sup>1/16</sup>	29 <sup>1/16</sup>	27 <sup>1/16</sup>	18 <sup>1/8</sup>	3	13 <sup>5/8</sup>	19 <sup>1/4</sup>	—
	254T-256T		16			37 <sup>7/16</sup>	35 <sup>7/16</sup>			22		
HDBI-160	143T-184T	9 <sup>1/4</sup>	7 <sup>5/8</sup>	19 <sup>1/8</sup>	9 <sup>1/16</sup>	30 <sup>3/16</sup>	28 <sup>3/16</sup>	19 <sup>3/4</sup>	3	13 <sup>5/8</sup>	21 <sup>1/8</sup>	—
	213T-256T		17			39 <sup>9/16</sup>	37 <sup>9/16</sup>			23		
HDBI-180	143T-215T	9 <sup>15/16</sup>	8 <sup>3/8</sup>	21 <sup>1/2</sup>	9 <sup>1/16</sup>	32 <sup>5/16</sup>	30 <sup>5/16</sup>	22 <sup>3/4</sup>	3	14 <sup>3/8</sup>	23 <sup>1/2</sup>	—
	254T-286T		18 <sup>1/2</sup>			42 <sup>7/16</sup>	40 <sup>7/16</sup>			24 <sup>1/2</sup>		
	324T-326T		21			44 <sup>15/16</sup>	42 <sup>15/16</sup>			27		
HDBI-200	182T-256T	10 <sup>5/8</sup>	11 <sup>1/2</sup>	23 <sup>1/2</sup>	9 <sup>1/16</sup>	36 <sup>13/16</sup>	34 <sup>13/16</sup>	23 <sup>1/2</sup>	3	17 <sup>1/2</sup>	25 <sup>1/2</sup>	—
	284T-286T		18 <sup>1/2</sup>			43 <sup>13/16</sup>	41 <sup>13/16</sup>			24 <sup>1/2</sup>		
	324T-326T		21			46 <sup>5/16</sup>	44 <sup>5/16</sup>			27		
HDBI-220	182T-256T	11 <sup>7/16</sup>	11 <sup>1/2</sup>	26 <sup>1/8</sup>	9 <sup>1/16</sup>	38 <sup>7/16</sup>	36 <sup>7/16</sup>	26 <sup>1/4</sup>	3	17 <sup>1/2</sup>	28 <sup>1/8</sup>	—
	284T-326T		21			47 <sup>15/16</sup>	45 <sup>15/16</sup>			27		
HDBI-240	213T-256T	12 <sup>5/16</sup>	11 <sup>1/2</sup>	28 <sup>1/4</sup>	9 <sup>1/16</sup>	42 <sup>1/8</sup>	38 <sup>1/8</sup>	28 <sup>1/2</sup>	3	17 <sup>1/2</sup>	30 <sup>3/4</sup>	—
	284T-326T		21			51 <sup>5/8</sup>	47 <sup>5/8</sup>			27		
HDBI-270	213T-256T	13 <sup>1/4</sup>	11 <sup>1/2</sup>	31	9 <sup>1/16</sup>	44	40	31 <sup>1/4</sup>	3	17 <sup>1/2</sup>	33 <sup>3/4</sup>	—
	284T-326T		21			53 <sup>1/2</sup>	49 <sup>1/2</sup>			27		
HDBI-300	213T-256T	14 <sup>3/8</sup>	11 <sup>1/2</sup>	34 <sup>1/4</sup>	9 <sup>1/16</sup>	46 <sup>5/16</sup>	42 <sup>5/16</sup>	34 <sup>1/2</sup>	3	17 <sup>1/2</sup>	37 <sup>1/4</sup>	—
	284T-326T		21			55 <sup>13/16</sup>	51 <sup>13/16</sup>			27		
HDBI-330	284T-326T	15 <sup>15/16</sup>	20	28	3/4	55 <sup>1/8</sup>	54 <sup>15/16</sup>	38 <sup>3/4</sup>	3 1/2	27	30	41 <sup>3/4</sup>
	364T-405T		25			60 <sup>1/8</sup>	59 <sup>15/16</sup>			32		
	444T		29			64 <sup>1/8</sup>	63 <sup>15/16</sup>			36		
HDBI-360	284T-326T	17 <sup>1/8</sup>	20	31	3/4	57 <sup>1/2</sup>	57 <sup>5/16</sup>	42	3 1/2	27	33	45
	364T-405T		25			62 <sup>1/2</sup>	62 <sup>5/16</sup>			32		
	444T		29			66 <sup>1/2</sup>	66 <sup>5/16</sup>			36		

DIMENSIONS SUBJECT TO CHANGE WITHOUT NOTICE.



# DIMENSIONS and SPECIFICATIONS

## Arrangement #4HM, Direct Drive

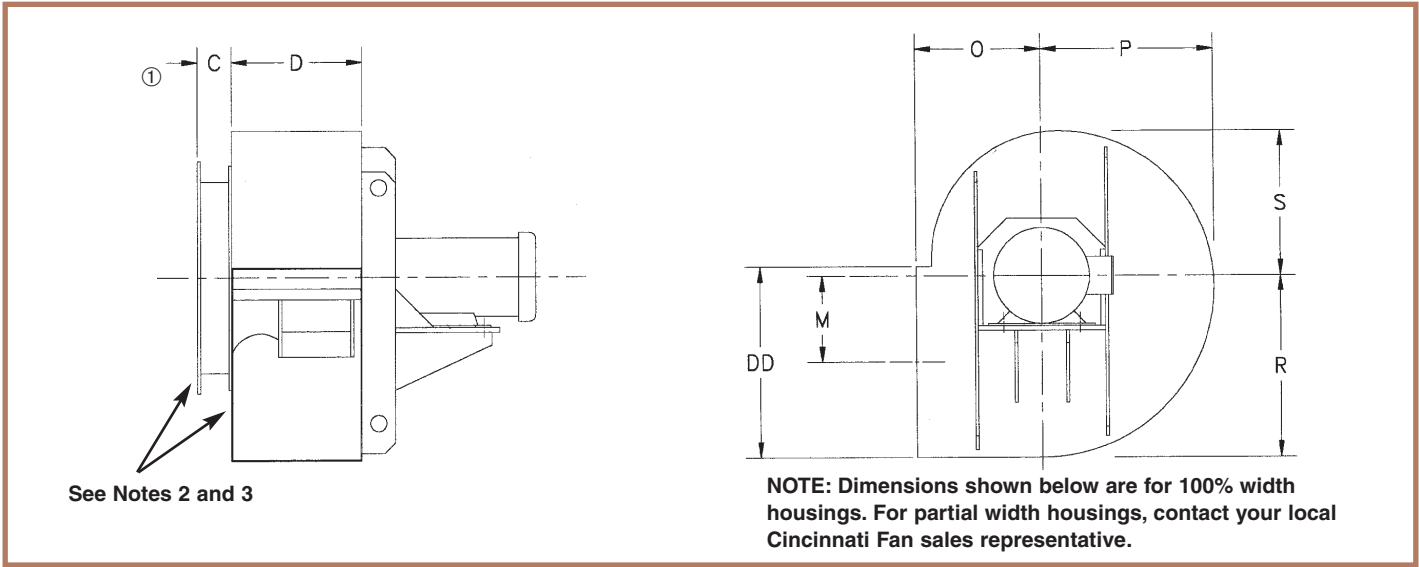

- ① Add 1/8" for AMCA "C" Construction.
- ② Optional inlet flange may be added to assist in fan installation. See page 31 for flange dimensions.
- ③ Discharge flange is optional on Models HDDB-120 through HDDB-240 and is standard on Models HDDB-270 and HDDB-300. See page 31 for flange dimensions.

### DIMENSIONS IN INCHES ± 1/8"

MODEL NO.	MOTOR FRAME	① C	D	M	O	P	R	S	③ DD	SHIP WT. LESS MOTOR
HDDB-120	143T-184T	4 1/4	9 3/8	6 3/16	9 15/16	12 3/8	13	10 3/8	13 3/4	150
HDDB-130	143T-215T	4 1/4	10 3/8	6 13/16	10 13/16	13 3/4	14 7/16	11 9/16	15 1/4	170
HDDB-150	143T-215T	4 1/4	11 3/8	7 9/16	11 3/4	15 3/16	15 15/16	12 3/4	16 13/16	190
HDDB-160	143T-256T	4 1/4	12 1/2	8 5/16	12 11/16	16 11/16	17 1/2	14	18 7/16	210
HDDB-180	143T-326T	4 1/4	13 7/8	9 1/4	13 13/16	18 7/16	19 7/16	15 1/2	20 3/8	270
HDDB-200	182T-326T	4 1/4	15 1/4	10 1/16	14 15/16	20 1/4	21 1/4	17	22 3/8	320
HDDB-220	182T-326T	4 1/4	16 7/8	11 3/16	16 3/8	22 1/2	23 5/8	18 7/8	24 7/8	390
HDDB-240	213T-326T	6 1/4	18 9/16	12 5/16	18 13/16	24 3/4	26	20 3/4	27 3/8	450
HDDB-270	213T-326T	6 1/4	20 7/16	13 9/16	20 5/8	27 1/4	28 5/8	22 7/8	30 1/16	550
HDDB-300	213T-326T	6 1/4	22 3/4	15 1/8	22 5/8	30 3/8	31 7/8	25 1/2	33 9/16	640
HDDB-330	284T-365T	6 1/8	24 7/8	16 9/16	24 11/16	33 3/8	35	28	36 7/8	940
HDDB-360	284T-365T	6 1/8	27 1/4	18 1/8	27 3/16	36 1/2	38 1/4	30 1/2	40 1/4	1100

DIMENSIONS SUBJECT TO CHANGE WITHOUT NOTICE.

16 DISCHARGE POSITIONS AVAILABLE. 45° DISCHARGE POSITIONS NOT SHOWN.\*  
 Discharges shown are determined by viewing fan from motor or drive side.



**CW-TH**  
 Clockwise Top Horizontal Discharge



**CW-DB**  
 Clockwise Down-Blast Discharge



**CW-BH**  
 Clockwise Bottom Horizontal Discharge



**CW-UB**  
 Clockwise Up-Blast Discharge



**CCW-TH**  
 Counter-Clockwise Top Horizontal Discharge



**CCW-DB**  
 Counter-Clockwise Down-Blast Discharge



**CCW-BH**  
 Counter-Clockwise Bottom Horizontal Discharge



**CCW-UB**  
 Counter-Clockwise Up-Blast Discharge

★ Not available on models HDDB-270 through HDDB-360 or any other models with discharge flange option without special discharge extension. For arrangement 9CB units, contact your local Cincinnati Fan sales representative.

\* See (\*) on page 31.



# DIMENSIONS and SPECIFICATIONS

## Arrangement #1 and #9, Belt Drive (specify 9R or 9L.)

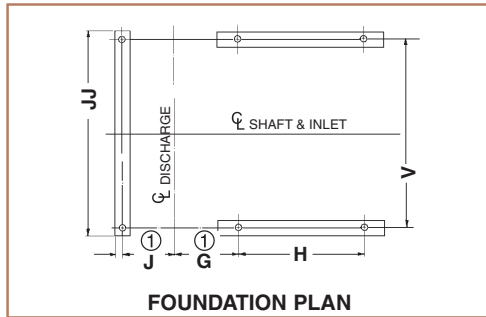
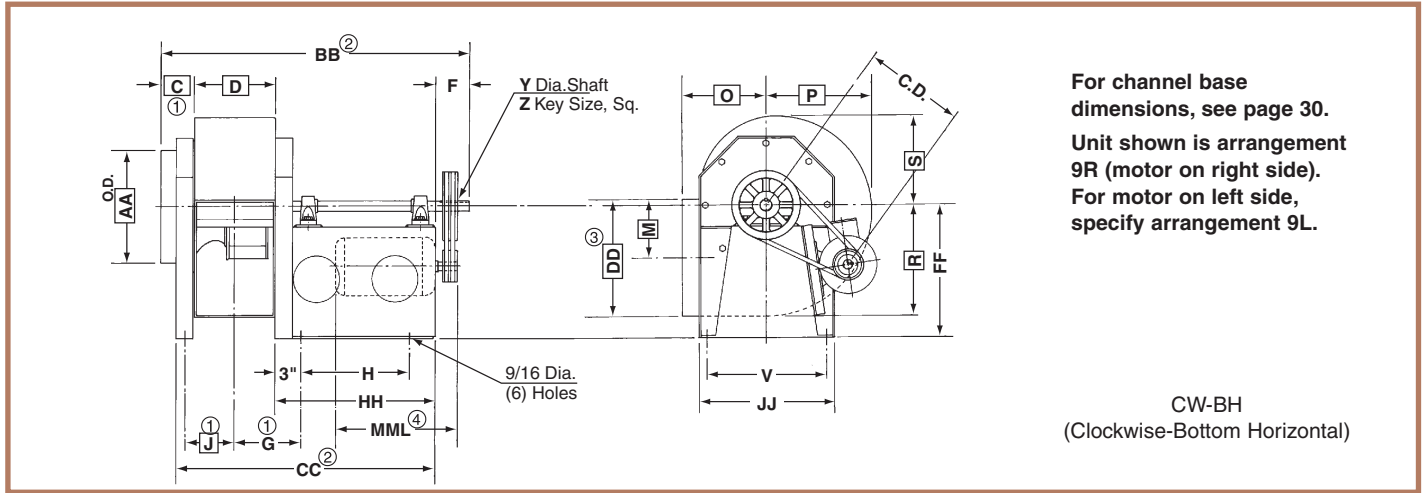

- ① Add 1/8" for AMCA "C" Construction fans and/or Downblast discharge position.
- ② Add 1/4" for AMCA "C" Construction fans and/or Downblast discharge position.
- ③ Discharge flange (not shown above) is standard on Models HDBI-270 and HDBI-300. See page 31 for dimensions.
- ④ MML IS MAXIMUM MOTOR LENGTH ON CUSTOMER SUPPLIED MOTOR. MOTOR MANUFACTURERS "C" DIMENSION CANNOT EXCEED "MML" WITHOUT A SPECIAL BASE.

NOTE: Housings are reversible and rotatable in 45° increments.  
Wheels are not reversible.

DIMENSIONS IN INCHES ± 1/8"

NOTE: For common boxed blower housing dimensions, see Page 24

MODEL NO.	MOTOR FRAME	F	① G	H	V	Y			Z			② BB	② CC	FF	HH	JJ	④ MML
						CL.II	CL.III	CL.IV	CL.II	CL.III	CL.IV						
HDBI-120	56-215T	4	7 <sup>11</sup> / <sub>16</sub>	12 <sup>3</sup> / <sub>4</sub>	14	1 <sup>3</sup> / <sub>16</sub>	1 <sup>3</sup> / <sub>16</sub>	—	1/4	1/4	—	36 <sup>3</sup> / <sub>16</sub>	30 <sup>3</sup> / <sub>16</sub>	15 <sup>1</sup> / <sub>2</sub>	18 <sup>3</sup> / <sub>4</sub>	16	19 <sup>3</sup> / <sub>8</sub>
HDBI-130	56-256T	4	8 <sup>3</sup> / <sub>16</sub>	17	15 <sup>3</sup> / <sub>4</sub>	1 <sup>3</sup> / <sub>16</sub>	1 <sup>7</sup> / <sub>16</sub>	1 <sup>7</sup> / <sub>16</sub>	1/4	3/8	3/8	41 <sup>7</sup> / <sub>16</sub>	35 <sup>7</sup> / <sub>16</sub>	16 <sup>5</sup> / <sub>8</sub>	23	17 <sup>3</sup> / <sub>4</sub>	24 <sup>1</sup> / <sub>4</sub>
HDBI-150	56-256T	4	8 <sup>11</sup> / <sub>16</sub>	17	17 <sup>1</sup> / <sub>4</sub>	1 <sup>7</sup> / <sub>16</sub>	1 <sup>11</sup> / <sub>16</sub>	1 <sup>11</sup> / <sub>16</sub>	3/8	3/8	3/8	42 <sup>7</sup> / <sub>16</sub>	36 <sup>7</sup> / <sub>16</sub>	18 <sup>1</sup> / <sub>8</sub>	23	19 <sup>1</sup> / <sub>4</sub>	24 <sup>1</sup> / <sub>4</sub>
HDBI-160	56-256T	4	9 <sup>1</sup> / <sub>4</sub>	17	19 <sup>1</sup> / <sub>8</sub>	1 <sup>7</sup> / <sub>16</sub>	1 <sup>11</sup> / <sub>16</sub>	1 <sup>15</sup> / <sub>16</sub>	3/8	3/8	1/2	43 <sup>9</sup> / <sub>16</sub>	37 <sup>9</sup> / <sub>16</sub>	19 <sup>3</sup> / <sub>4</sub>	23	21 <sup>1</sup> / <sub>8</sub>	24 <sup>1</sup> / <sub>4</sub>
HDBI-180	145T-286T	4	9 <sup>15</sup> / <sub>16</sub>	18 <sup>1</sup> / <sub>2</sub>	21 <sup>1</sup> / <sub>2</sub>	1 <sup>7</sup> / <sub>16</sub>	1 <sup>11</sup> / <sub>16</sub>	1 <sup>15</sup> / <sub>16</sub>	3/8	3/8	1/2	46 <sup>7</sup> / <sub>16</sub>	40 <sup>7</sup> / <sub>16</sub>	22 <sup>3</sup> / <sub>4</sub>	24 <sup>1</sup> / <sub>2</sub>	23 <sup>1</sup> / <sub>2</sub>	26 <sup>3</sup> / <sub>8</sub>
HDBI-200	145T-286T	4	10 <sup>5</sup> / <sub>8</sub>	18 <sup>1</sup> / <sub>2</sub>	23 <sup>1</sup> / <sub>2</sub>	1 <sup>7</sup> / <sub>16</sub>	1 <sup>15</sup> / <sub>16</sub>	2 <sup>3</sup> / <sub>16</sub>	3/8	1/2	1/2	47 <sup>13</sup> / <sub>16</sub>	41 <sup>13</sup> / <sub>16</sub>	23 <sup>1</sup> / <sub>2</sub>	24 <sup>1</sup> / <sub>2</sub>	25 <sup>1</sup> / <sub>2</sub>	26 <sup>3</sup> / <sub>8</sub>
HDBI-220	145T-324T	5	11 <sup>7</sup> / <sub>16</sub>	21	26 <sup>1</sup> / <sub>8</sub>	1 <sup>7</sup> / <sub>16</sub>	1 <sup>15</sup> / <sub>16</sub>	2 <sup>3</sup> / <sub>16</sub>	3/8	1/2	1/2	52 <sup>15</sup> / <sub>16</sub>	45 <sup>15</sup> / <sub>16</sub>	26 <sup>1</sup> / <sub>4</sub>	27	28 <sup>1</sup> / <sub>8</sub>	29 <sup>1</sup> / <sub>2</sub>
HDBI-240	145T-324T	6	12 <sup>5</sup> / <sub>16</sub>	21	28 <sup>1</sup> / <sub>4</sub>	1 <sup>11</sup> / <sub>16</sub>	2 <sup>3</sup> / <sub>16</sub>	2 <sup>3</sup> / <sub>16</sub>	3/8	1/2	1/2	57 <sup>5</sup> / <sub>8</sub>	47 <sup>5</sup> / <sub>8</sub>	28 <sup>1</sup> / <sub>2</sub>	27	30 <sup>3</sup> / <sub>4</sub>	29 <sup>1</sup> / <sub>2</sub>
HDBI-270	182T-324T	6	13 <sup>1</sup> / <sub>4</sub>	21	31	1 <sup>11</sup> / <sub>16</sub>	2 <sup>3</sup> / <sub>16</sub>	2 <sup>7</sup> / <sub>16</sub>	3/8	1/2	5/8	59 <sup>1</sup> / <sub>2</sub>	49 <sup>1</sup> / <sub>2</sub>	31 <sup>1</sup> / <sub>4</sub>	27	33 <sup>3</sup> / <sub>4</sub>	29 <sup>1</sup> / <sub>2</sub>
HDBI-300	182T-364T	6	14 <sup>3</sup> / <sub>8</sub>	24 <sup>3</sup> / <sub>4</sub>	34 <sup>1</sup> / <sub>4</sub>	1 <sup>15</sup> / <sub>16</sub>	2 <sup>7</sup> / <sub>16</sub>	2 <sup>7</sup> / <sub>16</sub>	1/2	5/8	5/8	65 <sup>9</sup> / <sub>16</sub>	55 <sup>9</sup> / <sub>16</sub>	34 <sup>1</sup> / <sub>2</sub>	30 <sup>3</sup> / <sub>4</sub>	37 <sup>1</sup> / <sub>4</sub>	33 <sup>1</sup> / <sub>4</sub>

FOR HDBI-330 & 360 DIMENSIONS, SEE PAGE 28.

DIMENSIONS SUBJECT TO CHANGE WITHOUT NOTICE.

### C.D. BELT CENTER DISTANCE

DIMENSIONS IN INCHES

MODEL	56-145T		182T-184T		213T-215T		254T-256T		284T-286T		324T-326T		364T	
	MIN.	MAX.	MIN.	MAX.	MIN.	MAX.	MIN.	MAX.	MIN.	MAX.	MIN.	MAX.	MIN.	MAX.
HDBI-120	11 <sup>3</sup> / <sub>16</sub>	12 <sup>3</sup> / <sub>4</sub>	12 <sup>1</sup> / <sub>8</sub>	13 <sup>1</sup> / <sub>2</sub>	12 <sup>5</sup> / <sub>16</sub>	13 <sup>11</sup> / <sub>16</sub>								
HDBI-130	11 <sup>1</sup> / <sub>8</sub>	12 <sup>11</sup> / <sub>16</sub>	12 <sup>13</sup> / <sub>16</sub>	14 <sup>3</sup> / <sub>8</sub>	13 <sup>1</sup> / <sub>8</sub>	14 <sup>11</sup> / <sub>16</sub>	13 <sup>7</sup> / <sub>16</sub>	14 <sup>13</sup> / <sub>16</sub>						
HDBI-150	11 <sup>5</sup> / <sub>8</sub>	13 <sup>3</sup> / <sub>16</sub>	13 <sup>7</sup> / <sub>16</sub>	14 <sup>15</sup> / <sub>16</sub>	13 <sup>7</sup> / <sub>8</sub>	15 <sup>5</sup> / <sub>8</sub>	14 <sup>5</sup> / <sub>16</sub>	16						
HDBI-160	12 <sup>3</sup> / <sub>16</sub>	13 <sup>11</sup> / <sub>16</sub>	14	15 <sup>1</sup> / <sub>2</sub>	15 <sup>1</sup> / <sub>8</sub>	17 <sup>3</sup> / <sub>16</sub>	15 <sup>11</sup> / <sub>16</sub>	17 <sup>5</sup> / <sub>8</sub>						
HDBI-180	12 <sup>7</sup> / <sub>8</sub>	14 <sup>3</sup> / <sub>8</sub>	14 <sup>9</sup> / <sub>16</sub>	16 <sup>1</sup> / <sub>16</sub>	15 <sup>13</sup> / <sub>16</sub>	17 <sup>11</sup> / <sub>16</sub>	17 <sup>1</sup> / <sub>2</sub>	19 <sup>11</sup> / <sub>16</sub>	17 <sup>13</sup> / <sub>16</sub>	19 <sup>3</sup> / <sub>16</sub>				
HDBI-200	12 <sup>5</sup> / <sub>8</sub>	14 <sup>1</sup> / <sub>4</sub>	14 <sup>1</sup> / <sub>4</sub>	15 <sup>7</sup> / <sub>8</sub>	15 <sup>5</sup> / <sub>8</sub>	17 <sup>1</sup> / <sub>2</sub>	17 <sup>1</sup> / <sub>4</sub>	19 <sup>9</sup> / <sub>16</sub>	18 <sup>1</sup> / <sub>8</sub>	20 <sup>13</sup> / <sub>16</sub>				
HDBI-220	13 <sup>9</sup> / <sub>16</sub>	15 <sup>1</sup> / <sub>16</sub>	15 <sup>3</sup> / <sub>16</sub>	16 <sup>5</sup> / <sub>8</sub>	16 <sup>7</sup> / <sub>16</sub>	18 <sup>3</sup> / <sub>16</sub>	18 <sup>1</sup> / <sub>8</sub>	20 <sup>1</sup> / <sub>4</sub>	19 <sup>1</sup> / <sub>4</sub>	21 <sup>3</sup> / <sub>4</sub>	20 <sup>3</sup> / <sub>4</sub>	22 <sup>9</sup> / <sub>16</sub>		
HDBI-240	13 <sup>11</sup> / <sub>16</sub>	15 <sup>3</sup> / <sub>16</sub>	15 <sup>7</sup> / <sub>16</sub>	16 <sup>15</sup> / <sub>16</sub>	16 <sup>11</sup> / <sub>16</sub>	18 <sup>9</sup> / <sub>16</sub>	18 <sup>1</sup> / <sub>2</sub>	20 <sup>11</sup> / <sub>16</sub>	19 <sup>7</sup> / <sub>16</sub>	22	21 <sup>5</sup> / <sub>16</sub>	24 <sup>3</sup> / <sub>8</sub>		
HDBI-270			16	17 <sup>1</sup> / <sub>2</sub>	17 <sup>5</sup> / <sub>16</sub>	19 <sup>3</sup> / <sub>16</sub>	19	21 <sup>1</sup> / <sub>4</sub>	20 <sup>1</sup> / <sub>16</sub>	22 <sup>11</sup> / <sub>16</sub>	21 <sup>15</sup> / <sub>16</sub>	25 <sup>1</sup> / <sub>16</sub>		
HDBI-300			15 <sup>15</sup> / <sub>16</sub>	17 <sup>5</sup> / <sub>16</sub>	17 <sup>15</sup> / <sub>16</sub>	19 <sup>3</sup> / <sub>4</sub>	19 <sup>9</sup> / <sub>16</sub>	21 <sup>11</sup> / <sub>16</sub>	20 <sup>5</sup> / <sub>8</sub>	23 <sup>1</sup> / <sub>8</sub>	22 <sup>7</sup> / <sub>16</sub>	25 <sup>1</sup> / <sub>2</sub>	23 <sup>15</sup> / <sub>16</sub>	27 <sup>3</sup> / <sub>8</sub>



# DIMENSIONS and SPECIFICATIONS

## HDBI-330 & 360, Arrangement #1 and #9, Belt Drive (specify 9R or 9L)

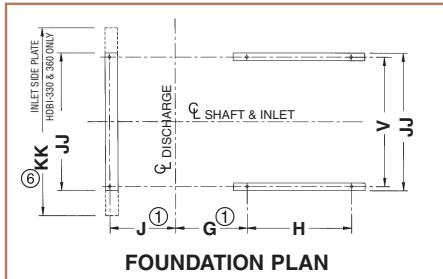
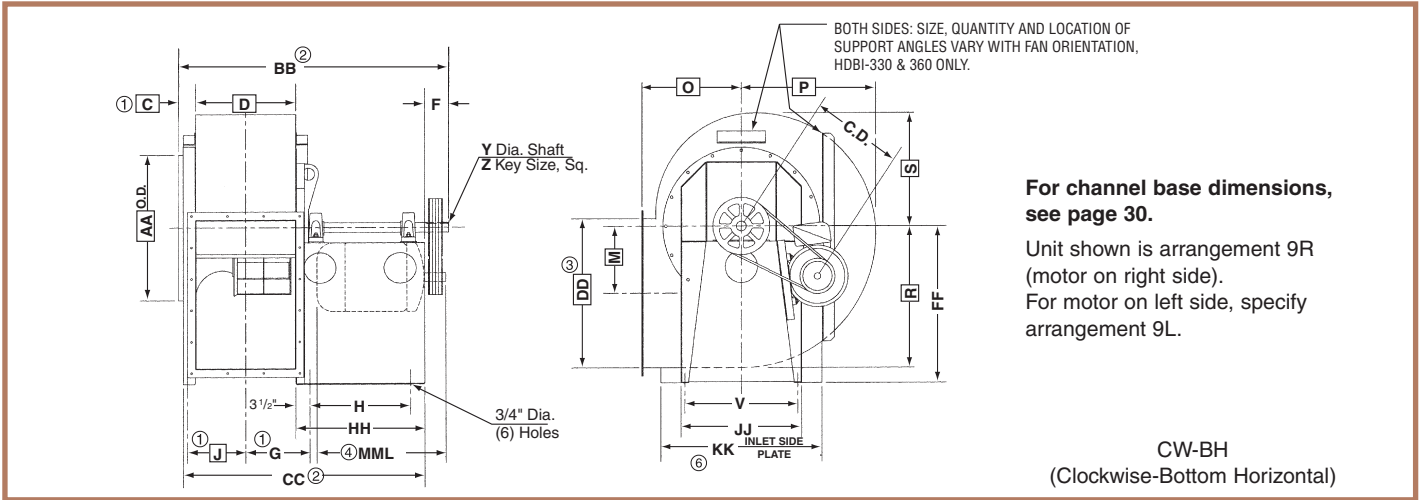

**NOTE: HDBI-330 AND 360 are not rotatable or reversible.**

- ① Add 1/8" for AMCA "C" Construction fans and/or Downblast discharge position.
- ② Add 1/4" for AMCA "C" Construction fans and/or Downblast discharge position.
- ③ Discharge flange is standard on Models HDBI-330 and HDBI-360. See page 31 for dimensions.
- ④ MML IS MAXIMUM MOTOR LENGTH ON CUSTOMER SUPPLIED MOTOR. MOTOR MANUFACTURERS "C" DIMENSION CANNOT EXCEED "MML" WITHOUT A SPECIAL BASE.
- ⑥ Inlet side plate width for HDBI-330 & 360.

DIMENSIONS IN INCHES ± 1/8"

DIMENSIONS SUBJECT TO CHANGE WITHOUT NOTICE.

MODEL	MOTOR FRAME	F	① G	H	V	Y			Z			② BB	② CC	FF	HH	JJ	⑥ KK	④ MML
						CL.II	CL.III	CL.IV	CL.II	CL.III	CL.IV							
HDBI-330	182T-365T	6	15 <sup>15/16</sup>	25	28	2 <sup>3/16</sup>	2 <sup>7/16</sup>	2 <sup>11/16</sup>	1/2	5/8	5/8	66 <sup>1/8</sup>	59 <sup>15/16</sup>	38 <sup>3/4</sup>	32	30	41 <sup>3/4</sup>	33
HDBI-360	182T-365T	6	17 <sup>1/8</sup>	25	31	2 <sup>7/16</sup>	2 <sup>11/16</sup>	2 <sup>15/16</sup>	5/8	5/8	3/4	68 <sup>1/2</sup>	62 <sup>5/16</sup>	42	32	33	45	33

**Note: For common boxed blower housing dimensions, see Page 24.**

### C.D. BELT CENTER DISTANCE

MOTOR FRAME	CLASS II & III		CLASS IV	
	MIN.	MAX.	MIN.	MAX.
182T-184T	17 <sup>9/16</sup>	18 <sup>5/8</sup>	17 <sup>7/8</sup>	19 <sup>3/16</sup>
213T-215T	18 <sup>7/8</sup>	20 <sup>5/16</sup>	19 <sup>3/16</sup>	20 <sup>7/8</sup>
254T-256T	20 <sup>9/16</sup>	22 <sup>5/16</sup>	21 <sup>1/16</sup>	22 <sup>7/8</sup>
184T-286T	21 <sup>9/16</sup>	23 <sup>11/16</sup>	22 <sup>1/8</sup>	24 <sup>5/16</sup>
324T-326T	23 <sup>1/2</sup>	26 <sup>1/16</sup>	24	26 <sup>11/16</sup>
364T-365T	24 <sup>15/16</sup>	28	25 <sup>3/8</sup>	28 <sup>5/8</sup>

16 DISCHARGE POSITIONS AVAILABLE. 45° DISCHARGE POSITIONS NOT SHOWN.\*  
Discharges shown are determined by viewing fan from motor or drive side.



**CW-TH**  
Clockwise Top Horizontal Discharge



**CW-DB**  
Clockwise Down-Blast Discharge



**CW-BH**  
Clockwise Bottom Horizontal Discharge



**CW-UB**  
Clockwise Up-Blast Discharge



**CCW-TH**  
Counter-Clockwise Top Horizontal Discharge



**CCW-DB**  
Counter-Clockwise Down-Blast Discharge



**CCW-BH**  
Counter-Clockwise Bottom Horizontal Discharge



**CCW-UB**  
Counter-Clockwise Up-Blast Discharge

★ Not available on models HDBI-270 through HDBI-360 or any other models with discharge flange option without special discharge extension. For arrangement 9CB units, contact your local Cincinnati Fan sales representative.

\* See (\*) on page 31.



# DIMENSIONS and SPECIFICATIONS

## Arrangement #10, Belt Drive

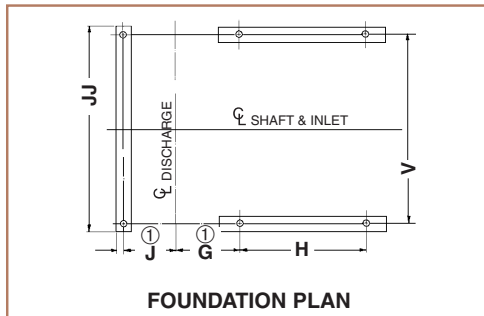
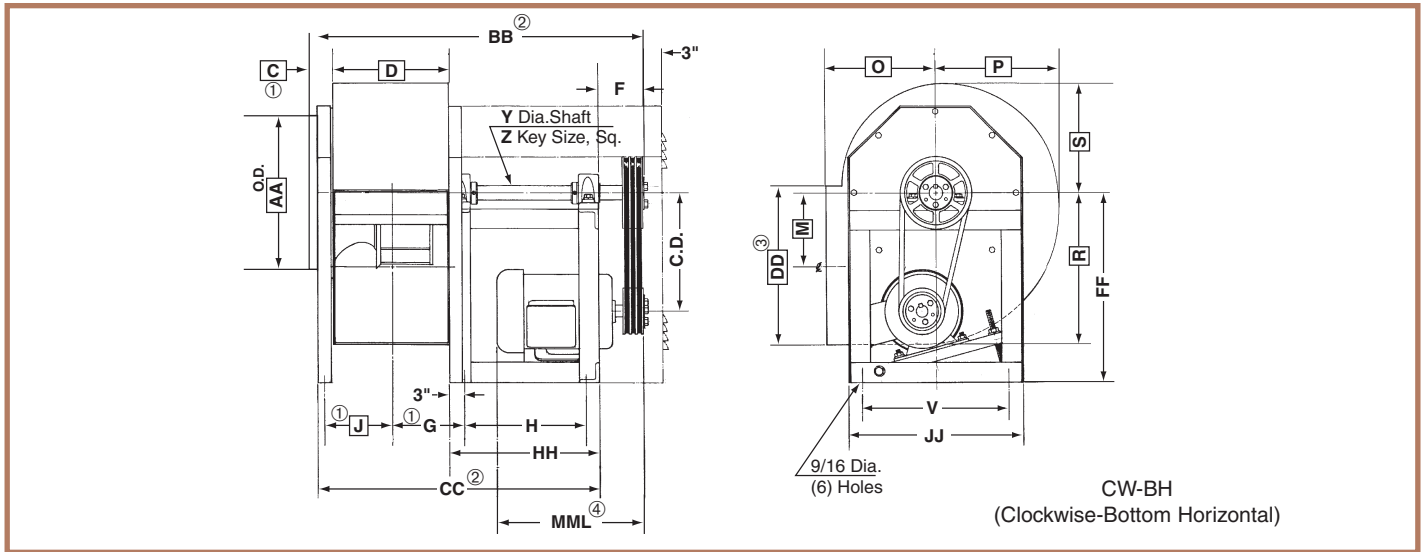

- ① Add 1/8" for AMCA "C" Construction fans and/or Downblast discharge position.
- ② Add 1/4" for AMCA "C" Construction fans and/or Downblast discharge position.
- ③ Discharge flange (not shown above) is standard on Models HDBI-270 and HDBI-300. See page 31 for dimensions.
- ④ MML IS MAXIMUM MOTOR LENGTH ON CUSTOMER SUPPLIED MOTOR. MOTOR MANUFACTURERS "C" DIMENSION CANNOT EXCEED "MML" WITHOUT A SPECIAL BASE.

NOTE: Housings are reversible and rotatable in 45° increments. Wheels are not reversible.

DIMENSIONS IN INCHES ± 1/8"

NOTE: For common boxed blower housing dimensions, see Page 24.

MODEL NO.	MOTOR FRAME	F	① G	H	V	Y			Z			② BB	② CC	FF	HH	JJ	④ MML
						CL.II	CL.III	CL.IV	CL.II	CL.III	CL.IV						
HDBI-120	56-184T	4 1/8	7 11/16	12 3/4	14	1 3/16	1 3/16	—	1/4	1/4	—	36 3/16	30 3/16	15 1/2	18 5/8	16	18 7/8
HDBI-130	56-184T	4 1/8	8 3/16	17	15 3/4	1 3/16	1 7/16	1 7/16	1/4	3/8	3/8	41 7/16	35 5/16	16 5/8	22 7/8	17 3/4	23 1/8
HDBI-150	56-215T	4 1/8	8 11/16	17	17 1/4	1 7/16	1 11/16	1 11/16	3/8	3/8	3/8	42 7/16	36 5/16	18 1/8	22 7/8	19 1/4	24 1/4
HDBI-160	56-215T	4 1/8	9 1/4	17	19 1/8	1 7/16	1 11/16	1 15/16	3/8	3/8	1/2	43 9/16	37 7/16	19 3/4	22 7/8	21 1/8	24 1/4
HDBI-180	56-256T	4 1/8	9 15/16	18 1/2	21 1/2	1 7/16	1 11/16	1 15/16	3/8	3/8	1/2	46 7/16	40 5/16	22 3/4	24 3/8	23 1/2	26 5/8
HDBI-200	56-256T	4 1/8	10 5/8	18 1/2	23 1/2	1 7/16	1 15/16	2 3/16	3/8	1/2	1/2	47 13/16	41 11/16	23 1/2	24 3/8	25 1/2	26 5/8
HDBI-220	145T-286T	5 1/8	11 7/16	21	26 1/8	1 7/16	1 15/16	2 3/16	3/8	1/2	1/2	52 15/16	45 13/16	26 1/4	26 7/8	28 1/8	29 3/4
HDBI-240	145T-324T	6 3/16	12 5/16	21	28 1/4	1 11/16	2 3/16	2 3/16	3/8	1/2	1/2	57 5/8	47 7/16	28 1/2	26 15/16	30 3/4	29 5/8
HDBI-270	182T-324T	6 3/16	13 1/4	21	31	1 11/16	2 3/16	2 7/16	3/8	1/2	5/8	59 1/2	49 5/16	31 1/4	26 15/16	33 3/4	29 5/8
HDBI-300	182T-324T	6 3/16	14 3/8	24 3/4	34 1/4	1 15/16	2 7/16	2 7/16	1/2	5/8	5/8	65 9/16	65 9/16	34 1/2	30 9/16	37 1/4	33 3/8

HDBI-330 and HDBI-360 are not available in Arrangement 10.

DIMENSIONS SUBJECT TO CHANGE WITHOUT NOTICE.

### C.D. BELT CENTER DISTANCE

DIMENSIONS IN INCHES

MODEL	56		143T-145T		182T-184T		213T-215T		254T-256T		284T-186T		324T	
	MIN.	MAX.	MIN.	MAX.	MIN.	MAX.	MIN.	MAX.	MIN.	MAX.	MIN.	MAX.	MIN.	MAX.
HDBI-120	8 1/8	10	8 1/8	10	7 1/2	9								
HDBI-130	9 1/4	11 1/8	9 1/4	11 1/8	8 3/8	10 1/8								
HDBI-150	10	12 1/8	10	12 1/8	9 1/8	11 1/8	8 3/8	10 3/8						
HDBI-160	11 5/8	13 5/8	11 5/8	13 5/8	10 5/8	12 5/8	10	11 7/8						
HDBI-180	14	16 1/8	14	16 1/8	12 3/4	15 1/8	12	14 3/8	11 1/8	13 3/8				
HDBI-180	14 3/4	16 7/8	14 3/4	16 7/8	13 1/2	15 7/8	12 3/4	15 1/8	11	13				
HDBI-200			17	19 3/4	16 1/8	18 5/8	15 3/8	17 7/8	14 3/8	16 7/8	13 3/4	16 1/4		
HDBI-220			19 1/4	22	18 1/4	21	17 5/8	20 1/8	16 5/8	19 1/8	15 7/8	18 3/8	14 7/8	17 3/8
HDBI-240					21	23 3/4	20 3/8	22 7/8	19 3/8	21 7/8	18 5/8	21 1/8	17 5/8	20 1/8
HDBI-270					24 1/4	26 7/8	23 1/2	26 1/8	22 1/2	25 1/8	21 7/8	24 3/8	20 7/8	23 3/8
HDBI-300														

### ⚠ DANGER

All fans & blowers shown have rotating parts and pinch points. Severe personal injury can result if operated without guards. Stay away from rotating equipment unless it is disconnected from its power source.

Read operating instructions.



# DIMENSIONS and SPECIFICATIONS

HDBI-120 to 360, Arrangement #9RCB or #9LCB Channel Base, Belt Drive

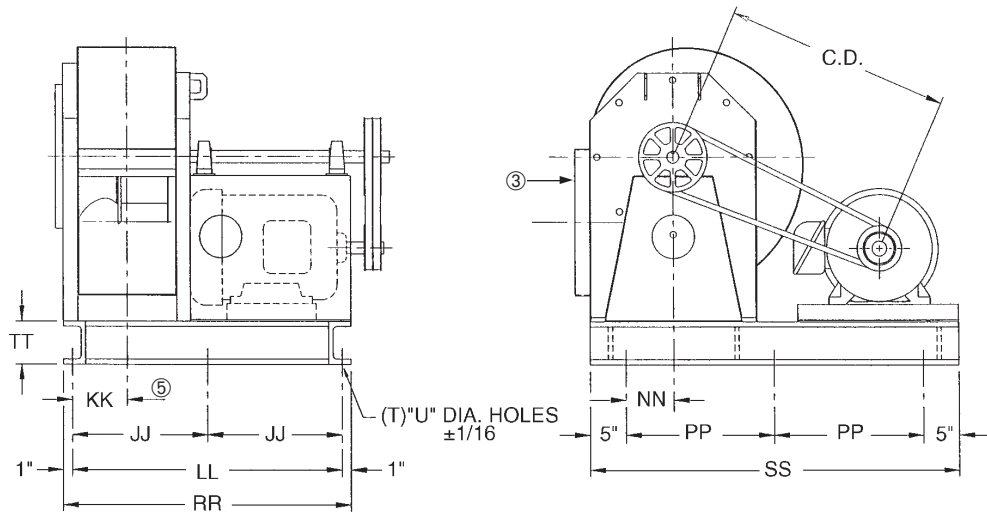

Unit shown is arrangement 9RCB (motor on right side). For motor on left side, specify arrangement 9LCB. Channel base arrangements not available in down blast or 45° bottom angular down discharge positions.

## DIMENSIONS IN INCHES ± 1/8"

MODEL	MOTOR FRAME	T	U	⑤ KK	JJ	LL	NN	PP	RR	SS	TT	Ship wt. less motor		
												CL.II	CL.III	CL.IV
HDBI-120	184T-215T	6	9/16	5 3/4	—	28 3/16	3	13 15/32	30 3/16	36 15/16	4	260	265	—
HDBI-130	184T-256T	6	9/16	6 1/4	—	33 7/16	3 7/8	15 13/16	35 7/16	41 5/8	4	300	305	310
HDBI-150	184T-284T	6	9/16	6 3/4	—	34 7/16	4 5/8	17 3/4	36 7/16	45 1/2	4	340	350	360
HDBI-160	184T-286T	6	9/16	7 5/16	—	35 9/16	5 9/16	18 11/16	37 9/16	47 3/8	4	390	400	410
HDBI-180	184T-324T	6	9/16	8	—	38 7/16	6 3/4	21 3/16	40 7/16	52 3/8	6	500	510	520
HDBI-200	254T-324T	6	9/16	8 11/16	—	39 13/16	7 3/4	22 3/16	41 13/16	54 3/8	6	560	580	590
HDBI-220	254T-364T	6	9/16	9 1/2	—	43 15/16	9 1/16	26 11/16	45 15/16	63 3/8	6	660	680	690
HDBI-240	254T-364T	6	9/16	10 11/32	—	48 1/8	10 3/8	28	50 1/8	66	6	800	810	820
HDBI-270	254T-364T	6	9/16	11 9/32	—	50	11 7/8	29 1/2	52	69	6	960	970	980
HDBI-300	254T-405T	6	9/16	12 7/16	—	56 1/16	13 5/8	31 1/4	58 1/16	72 1/2	6	1130	1165	1170
HDBI-330	254T-444T	8	3/4	14 1/2	30 7/32	60 7/16	10	32 11/16	62 7/16	75 3/8	6	1420	1560	1760
HDBI-360	254T-444T	8	3/4	15 11/16	31 13/32	62 13/16	11 1/2	32 11/16	64 13/16	75 3/8	6	1650	1840	1910

③ Discharge flange (not shown above) is standard on Models HDBI-270 through HDBI-360. See page 31 for dimensions.

⑤ Subtract 1/8" for AMCA "C" Construction.

Dimensions subject to change without notice.

## C.D. BELT CENTER DISTANCE

DIMENSIONS IN INCHES

MODEL	MOTOR FRAME SIZE															
	184T		213T-215T		254T-256T		284T-286T		324T-326T		364T-365T		404T-405T		444T	
	MIN.	MAX.	MIN.	MAX.	MIN.	MAX.	MIN.	MAX.	MIN.	MAX.	MIN.	MAX.	MIN.	MAX.	MIN.	MAX.
HDBI-120	23 5/8	25 7/8	21 15/16	24 11/16												
HDBI-130	27 1/2	29 5/8	25 7/8	28 5/8	23 15/16	27 3/16										
HDBI-150	31	33	29 5/16	32 1/8	27 3/8	30 5/8	25 15/16	29 11/16								
HDBI-160	32 5/8	34 13/16	30 7/8	33 9/16	28 7/8	32 1/16	27 7/16	31 1/16								
HDBI-180	37 1/4	39 1/4	35 5/8	38 1/4	33 5/8	36 11/16	32 1/8	35 3/4	29 13/16	34 1/8						
HDBI-200					34 13/16	37 15/16	33 3/8	36 15/16	31 1/16	35 5/16						
HDBI-220					42 15/16	46 1/16	41 1/2	45 1/8	39 3/16	43 1/2	37 3/16	42 3/16				
HDBI-240					45 1/8	48 3/16	43 11/16	47 3/16	41 5/16	45 9/16	39 5/16	44 1/4				
HDBI-270					47 3/4	50 3/4	46 1/4	49 3/4	43 15/16	48 1/16	41 15/16	46 3/4				
HDBI-300					50 7/8	53 13/16	49 7/16	52 13/16	47 1/16	51 1/8	45 1/16	49 3/4	42 7/16	47 13/16		
HDBI-330					58 5/8	61 9/16	57 3/16	60 1/2	54 13/16	58 13/16	52 13/16	57 7/16	53 1/8	58 13/16	51 9/16	57 11/16
HDBI-360					59 3/16	62	57 3/4	60 15/16	55 5/16	59 3/16	53 5/16	57 13/16	53 1/2	59	51 7/8	57 13/16



# DIMENSIONS and SPECIFICATIONS

## INLET AND OUTLET FLANGES

### INLET

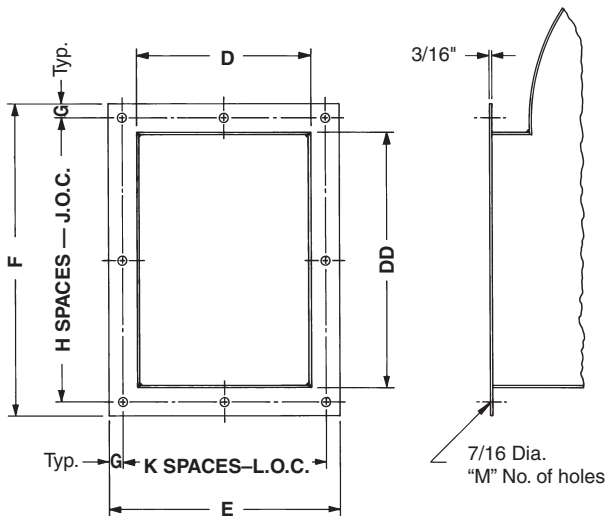
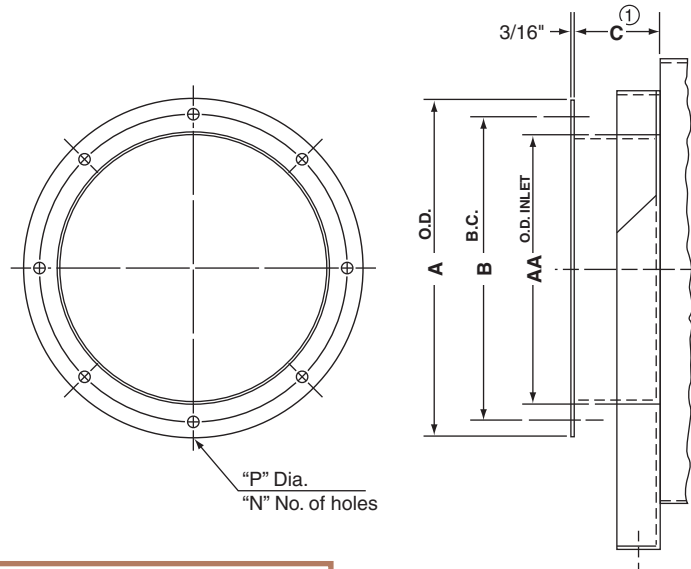

### OUTLET\*

\* Not available on: down blast, top angular down, or bottom angular down outlet positions for any models without discharge transition. Outlet flange standard on all HDBI-270 to HDBI-360. Dimensions shown below are for 100% width housings. For partial width housings, contact your local Cincinnati Fan sales representative.

**NOTE: Flanges will be drilled unless otherwise specified.**

DIMENSIONS IN INCHES ± 1/16" \*\*

DIMENSIONS SUBJECT TO CHANGE WITHOUT NOTICE.

MODEL	A	B	C <sup>①</sup> **	D**	E	F	G	H	J	K	L	M	N	P	AA**	DD**
HDBI-120	16	14 <sup>3</sup> / <sub>8</sub>	4 <sup>1</sup> / <sub>16</sub>	9 <sup>3</sup> / <sub>8</sub>	13 <sup>3</sup> / <sub>8</sub>	17 <sup>11</sup> / <sub>16</sub>	1	2	2 <sup>27</sup> / <sub>32</sub>	2	5 <sup>11</sup> / <sub>16</sub>	8	8	7 <sup>1</sup> / <sub>16</sub>	13 <sup>1</sup> / <sub>4</sub>	13 <sup>3</sup> / <sub>4</sub>
HDBI-130	17 <sup>3</sup> / <sub>4</sub>	15 <sup>15</sup> / <sub>16</sub>	4 <sup>1</sup> / <sub>16</sub>	10 <sup>3</sup> / <sub>8</sub>	14 <sup>3</sup> / <sub>8</sub>	19 <sup>3</sup> / <sub>16</sub>	1	2	8 <sup>19</sup> / <sub>32</sub>	2	6 <sup>3</sup> / <sub>16</sub>	8	8	7 <sup>1</sup> / <sub>16</sub>	14 <sup>5</sup> / <sub>8</sub>	15 <sup>1</sup> / <sub>4</sub>
HDBI-150	19 <sup>1</sup> / <sub>4</sub>	17 <sup>1</sup> / <sub>2</sub>	4 <sup>1</sup> / <sub>16</sub>	11 <sup>3</sup> / <sub>8</sub>	15 <sup>3</sup> / <sub>8</sub>	20 <sup>3</sup> / <sub>4</sub>	1	3	6 <sup>1</sup> / <sub>4</sub>	2	6 <sup>11</sup> / <sub>16</sub>	10	8	7 <sup>1</sup> / <sub>16</sub>	16 <sup>1</sup> / <sub>8</sub>	16 <sup>13</sup> / <sub>16</sub>
HDBI-160	21 <sup>1</sup> / <sub>8</sub>	19 <sup>3</sup> / <sub>8</sub>	4 <sup>1</sup> / <sub>16</sub>	12 <sup>1</sup> / <sub>2</sub>	16 <sup>1</sup> / <sub>2</sub>	22 <sup>7</sup> / <sub>16</sub>	1	3	6 <sup>13</sup> / <sub>16</sub>	2	7 <sup>1</sup> / <sub>4</sub>	10	8	7 <sup>1</sup> / <sub>16</sub>	18	18 <sup>7</sup> / <sub>16</sub>
HDBI-180	23 <sup>1</sup> / <sub>2</sub>	21 <sup>1</sup> / <sub>2</sub>	4 <sup>1</sup> / <sub>16</sub>	13 <sup>7</sup> / <sub>8</sub>	17 <sup>7</sup> / <sub>8</sub>	24 <sup>1</sup> / <sub>2</sub>	1	3	7 <sup>1</sup> / <sub>2</sub>	2	7 <sup>15</sup> / <sub>16</sub>	10	12	7 <sup>1</sup> / <sub>16</sub>	20	20 <sup>3</sup> / <sub>8</sub>
HDBI-200	25 <sup>1</sup> / <sub>2</sub>	23 <sup>1</sup> / <sub>2</sub>	4 <sup>1</sup> / <sub>16</sub>	15 <sup>1</sup> / <sub>4</sub>	19 <sup>1</sup> / <sub>4</sub>	26 <sup>3</sup> / <sub>8</sub>	1	3	8 <sup>1</sup> / <sub>8</sub>	3	5 <sup>3</sup> / <sub>4</sub>	12	12	7 <sup>1</sup> / <sub>16</sub>	22	22 <sup>3</sup> / <sub>8</sub>
HDBI-220	28 <sup>1</sup> / <sub>8</sub>	26 <sup>1</sup> / <sub>8</sub>	4 <sup>1</sup> / <sub>16</sub>	16 <sup>7</sup> / <sub>8</sub>	20 <sup>15</sup> / <sub>16</sub>	28 <sup>7</sup> / <sub>8</sub>	1	4	6 <sup>23</sup> / <sub>32</sub>	3	6 <sup>5</sup> / <sub>16</sub>	14	12	7 <sup>1</sup> / <sub>16</sub>	24 <sup>5</sup> / <sub>8</sub>	24 <sup>7</sup> / <sub>8</sub>
HDBI-240	30 <sup>3</sup> / <sub>4</sub>	28 <sup>3</sup> / <sub>4</sub>	6 <sup>1</sup> / <sub>16</sub>	18 <sup>9</sup> / <sub>16</sub>	22 <sup>5</sup> / <sub>8</sub>	31 <sup>3</sup> / <sub>8</sub>	1	4	7 <sup>11</sup> / <sub>32</sub>	3	6 <sup>7</sup> / <sub>8</sub>	14	16	7 <sup>1</sup> / <sub>16</sub>	27	27 <sup>3</sup> / <sub>8</sub>
HDBI-270	33 <sup>3</sup> / <sub>4</sub>	31 <sup>5</sup> / <sub>8</sub>	6 <sup>1</sup> / <sub>16</sub>	20 <sup>7</sup> / <sub>16</sub>	24 <sup>1</sup> / <sub>2</sub>	34 <sup>1</sup> / <sub>8</sub>	1	4	8 <sup>1</sup> / <sub>32</sub>	3	7 <sup>1</sup> / <sub>2</sub>	14	16	7 <sup>1</sup> / <sub>16</sub>	30	30 <sup>1</sup> / <sub>16</sub>
HDBI-300	37 <sup>1</sup> / <sub>4</sub>	35 <sup>1</sup> / <sub>4</sub>	6 <sup>1</sup> / <sub>16</sub>	22 <sup>3</sup> / <sub>4</sub>	26 <sup>3</sup> / <sub>4</sub>	37 <sup>5</sup> / <sub>8</sub>	1	5	7 <sup>1</sup> / <sub>8</sub>	3	8 <sup>1</sup> / <sub>4</sub>	16	16	7 <sup>1</sup> / <sub>16</sub>	33 <sup>1</sup> / <sub>2</sub>	33 <sup>9</sup> / <sub>16</sub>
★HDBI-330	40 <sup>3</sup> / <sub>8</sub>	38 <sup>3</sup> / <sub>4</sub>	6 <sup>1</sup> / <sub>16</sub>	24 <sup>7</sup> / <sub>8</sub>	28 <sup>7</sup> / <sub>8</sub>	40 <sup>7</sup> / <sub>8</sub>	1	7	5 <sup>9</sup> / <sub>16</sub>	5	5 <sup>3</sup> / <sub>8</sub>	24	16	1/2	36 <sup>3</sup> / <sub>4</sub>	36 <sup>7</sup> / <sub>8</sub>
★HDBI-360	43 <sup>5</sup> / <sub>8</sub>	42	6 <sup>1</sup> / <sub>16</sub>	27 <sup>1</sup> / <sub>4</sub>	31 <sup>1</sup> / <sub>4</sub>	44 <sup>1</sup> / <sub>4</sub>	1	7	6 <sup>1</sup> / <sub>32</sub>	5	5 <sup>27</sup> / <sub>32</sub>	24	16	1/2	40	40 <sup>1</sup> / <sub>4</sub>

① Add 1/8" for AMCA "C" Construction fans and/or Downblast discharge position.

★ HDBI-330 & 360 HAVE FIXED HOUSINGS AND ARE THEREFORE NOT ROTATABLE IN THE FIELD.

\*\*NOTE: Dimensions C, D, AA and DD are ± 1/8".